

ALL IN ONE
MATHEMATICS CHEAT SHEET

V2.6

Euler's Identity:

$$e^{i\pi} + 1 = 0$$

**CONTAINING FORMULAE FOR ELEMENTARY, HIGH SCHOOL
AND UNIVERSITY MATHEMATICS**

COMPILED FROM MANY SOURCES BY ALEX SPARTALIS
2009-2012

REVISION HISTORY

- 2.1. 08/06/2012
 - UPDATED: Format
 - NEW: Multivariable Calculus
 - UPDATED: Convergence tests
 - UPDATED: Composite Functions
- 2.2. 10/07/2012
 - NEW: Three Phase – Delta & Y
 - NEW: Electrical Power
- 2.3. 14/08/2012
 - NEW: Factorial
 - NEW: Electromagnetics
 - NEW: Linear Algebra
 - NEW: Mathematical Symbols
 - NEW: Algebraic Identities
 - NEW: Graph Theory
 - UPDATED: Linear Algebra
 - UPDATED: Linear Transformations
- 2.4. 31/08/2012
 - NEW: Graphical Functions
 - NEW: Prime numbers
 - NEW: Power Series Expansion
 - NEW: Inner Products
 - UPDATED: Pi Formulas
 - UPDATED: General Trigonometric Functions Expansion
 - UPDATED: Linear Algebra
 - UPDATED: Matrix Inverse
- 2.5. 10/09/2012
 - NEW: Machin-Like Formulae
 - NEW: Infinite Summations To Pi
 - NEW: Classical Mechanics
 - NEW: Relativistic Formulae
 - NEW: Statistical Distributions
 - NEW: Logarithm Power Series
 - NEW: Spherical Triangle Identities
 - NEW: Bernoulli Expansion
 - UPDATED: Pi Formulas
 - UPDATED: Logarithm Identities
 - UPDATED: Riemann Zeta Function
 - UPDATED: Eigenvalues and Eigenvectors
- 2.6. 3/10/2012
 - NEW: QR Factorisation
 - NEW: Jordan Forms
 - NEW: Macroeconomics
 - NEW: Golden Ratio & Fibonacci Sequence
 - NEW: Complex Vectors and Matrices
 - NEW: Numerical Computations for Matrices
 - UPDATED: Prime Numbers
 - UPDATED: Errors within Matrix Formula
- 2.7. 2012
 - TO DO: USV Decomposition

CONTENTS

REVISION HISTORY	2
-------------------------	----------

CONTENTS	3
-----------------	----------

PART 1: PHYSICAL CONSTANTS	20
-----------------------------------	-----------

1.1 SI PREFIXES:	20
1.2 SI BASE UNITS:	20
1.3 SI DERIVED UNITS:	21
1.4 UNIVERSAL CONSTANTS:	22
1.5 ELECTROMAGNETIC CONSTANTS:	22
1.6 ATOMIC AND NUCLEAR CONSTANTS:	22
1.7 PHYSICO-CHEMICAL CONSTANTS:	23
1.8 ADOPTED VALUES:	24
1.9 NATURAL UNITS:	25

PART 2: MATHEMATICAL SYMBOLS	26
-------------------------------------	-----------

2.1 BASIC MATH SYMBOLS	26
2.2 GEOMETRY SYMBOLS	26
2.3 ALGEBRA SYMBOLS	27
2.4 LINEAR ALGEBRA SYMBOLS	28
2.5 PROBABILITY AND STATISTICS SYMBOLS	28
2.6 COMBINATORICS SYMBOLS	30
2.7 SET THEORY SYMBOLS	30
2.8 LOGIC SYMBOLS	31
2.9 CALCULUS & ANALYSIS SYMBOLS	32

PART 3: AREA, VOLUME AND SURFACE AREA	33
--	-----------

3.1 AREA	33
TRIANGLE:	33
RECTANGLE:	33
SQUARE:	33
PARALLELOGRAM:	33
RHOMBUS:	33
TRAPEZIUM:	33
QUADRILATERAL:	33
RECTANGLE WITH ROUNDED CORNERS:	33
REGULAR HEXAGON:	33
REGULAR OCTAGON:	33
REGULAR POLYGON:	33
3.2 VOLUME	33
CUBE:	33
CUBOID:	33
PYRAMID:	33

TETRAHEDRON:	33
OCTAHEDRON:	33
DODECAHEDRON:	33
ICOSAHEDRON:	33
3.3 SURFACE AREA:	33
CUBE:	33
CUBOIDS:	33
TETRAHEDRON:	33
OCTAHEDRON:	34
DODECAHEDRON:	34
ICOSAHEDRON:	34
CYLINDER:	34
3.4 MISCELLANEOUS	34
DIAGONAL OF A RECTANGLE	34
DIAGONAL OF A CUBOID	34
LONGEST DIAGONAL (EVEN SIDES)	34
LONGEST DIAGONAL (ODD SIDES)	34
TOTAL LENGTH OF EDGES (CUBE):	34
TOTAL LENGTH OF EDGES (CUBOID):	34
CIRCUMFERENCE	34
PERIMETER OF RECTANGLE	34
SEMI PERIMETER	34
EULER'S FORMULA	34
3.5 ABBREVIATIONS (3.1, 3.2, 3.3, 3.4)	34

PART 4: ALGEBRA **36**

4.1 POLYNOMIAL FORMULA:	36
QUADRATIC:	36
CUBIC:	36
4.2 ALGEBRAIC EXPANSION:	38
BABYLONIAN IDENTITY:	38
COMMON PRODUCTS AND FACTORS:	38
BINOMIAL THEOREM:	38
BINOMIAL EXPANSION:	38
DIFFERENCE OF TWO SQUARES:	39
BRHMAGUPTA-FIBONACCI IDENTITY:	39
DEGEN'S EIGHT-SQUARE IDENTITY:	39
4.3 LIMIT MANIPULATIONS:	40
4.4 SUMMATION MANIPULATIONS:	40
4.5 COMMON FUNCTIONS:	40
CONSTANT FUNCTION:	40
LINE/LINEAR FUNCTION:	41
PARABOLA/QUADRATIC FUNCTION:	41
CIRCLE:	41
ELLIPSE:	41
HYPERBOLA:	42
4.6 LINEAR ALGEBRA:	42
VECTOR SPACE AXIOMS:	42
SUBSPACE:	42
COMMON SPACES:	42
ROWSPACE OF A SPANNING SET IN \mathbb{R}^N	43
COLUMNSPACE OF A SPANNING SET IN \mathbb{R}^N	43
NULLSPACE:	43
NULLITY:	43

LINEAR DEPENDENCE:	43
BASIS:	43
STANDARD BASIS:	44
ORTHOGONAL COMPLEMENT:	44
ORTHONORMAL BASIS:	44
GRAM-SCHMIDT PROCESS:	45
COORDINATE VECTOR:	45
DIMENSION:	45
4.7 COMPLEX VECTOR SPACES:	45
FORM:	45
DOT PRODUCT:	45
INNER PRODUCT:	46
4.8 LINEAR TRANSITIONS & TRANSFORMATIONS:	46
TRANSITION MATRIX:	46
CHANGE OF BASIS TRANSITION MATRIX:	46
TRANSFORMATION MATRIX:	46
4.9 INNER PRODUCTS:	46
DEFINITION:	46
AXIOMS:	46
UNIT VECTOR:	47
CAVCHY-SCHUARZ INEQUALITY:	47
INNER PRODUCT SPACE:	47
ANGLE BETWEEN TWO VECTORS:	47
DISTANCE BETWEEN TWO VECTORS:	47
GENERALISED PYTHAGORAS FOR ORTHOGONAL VECTORS:	47
4.10 PRIME NUMBERS:	47
DETERMINATE:	47
LIST OF PRIME NUMBERS:	47
PERFECT NUMBERS:	48
LIST OF PERFECT NUMBERS:	48
AMICABLE NUMBERS:	49
LIST OF AMICABLE NUMBERS:	49
SOCIABLE NUMBERS:	50
LIST OF SOCIABLE NUMBERS:	50
4.11 GOLDEN RATIO & FIBONACCI SEQUENCE:	53
RELATIONSHIP:	53
INFINITE SERIES:	53
CONTINUED FRACTIONS:	53
TRIGONOMETRIC EXPRESSIONS:	54
FIBONACCI SEQUENCE:	54
4.12 FERMAT'S LAST THEOREM:	54
PART 5: COUNTING TECHNIQUES & PROBABILITY	55
5.1 2D	55
TRIANGLE NUMBER	55
SQUARE NUMBER	55
PENTAGONAL NUMBER	55
5.2 3D	55
TETRAHEDRAL NUMBER	55
SQUARE PYRAMID NUMBER	55
5.3 PERMUTATIONS	55
PERMUTATIONS:	55
PERMUTATIONS (WITH REPEATS):	55
5.4 COMBINATIONS	55

ORDERED COMBINATIONS:	55
UNORDERED COMBINATIONS:	55
ORDERED REPEATED COMBINATIONS:	55
UNORDERED REPEATED COMBINATIONS:	55
GROUPING:	55
5.5 MISCELLANEOUS:	55
TOTAL NUMBER OF RECTANGLES AND SQUARES FROM A A X B RECTANGLE:	55
NUMBER OF INTERPRETERS:	55
MAX NUMBER OF PIZZA PIECES:	55
MAX PIECES OF A CRESCENT:	55
MAX PIECES OF CHEESE:	55
CARDS IN A CARD HOUSE:	56
DIFFERENT ARRANGEMENT OF DOMINOS:	56
UNIT FRACTIONS:	56
ANGLE BETWEEN TWO HANDS OF A CLOCK:	56
WINNING LINES IN NOUGHTS AND CROSSES:	56
BAD RESTAURANT SPREAD:	56
FIBONACCI SEQUENCE:	56
ABBREVIATIONS (5.1, 5.2, 5.3, 5.4, 5.5)	56
5.6 FACTORIAL:	56
DEFINITION:	56
TABLE OF FACTORIALS:	56
APPROXIMATION:	57
5.7 THE DAY OF THE WEEK:	57
5.8 BASIC PROBABILITY:	57
5.9 VENN DIAGRAMS:	57
COMPLEMENTARY EVENTS:	57
TOTALITY:	57
CONDITIONAL PROBABILITY:	57
UNION :	57
INDEPENDENT EVENTS:	57
MUTUALLY EXCLUSIVE:	57
BAYE'S THEOREM:	57
5.11 BASIC STATISTICAL OPERATIONS:	58
VARIANCE:	58
MEAN:	58
STANDARDIZED SCORE:	58
5.12 DISCRETE RANDOM VARIABLES:	58
STANDARD DEVIATION:	58
EXPECTED VALUE:	58
VARIANCE:	58
PROBABILITY MASS FUNCTION:	58
CUMULATIVE DISTRIBUTION FUNCTION:	58
5.13 COMMON DRVs:	58
BERNOULLI TRIAL:	58
BINOMIAL TRIAL:	58
GEOMETRIC TRIAL:	59
NEGATIVE BINOMIAL TRIAL:	59
5.14 CONTINUOUS RANDOM VARIABLES:	59
PROBABILITY DENSITY FUNCTION:	59
CUMULATIVE DISTRIBUTION FUNCTION:	59
INTERVAL PROBABILITY:	59
EXPECTED VALUE:	59
VARIANCE:	59
5.15 COMMON CRVs:	59
UNIFORM DISTRIBUTION:	59

EXPONENTIAL DISTRIBUTION:	60
NORMAL DISTRIBUTION:	61
5.16 MULTIVARIABLE DISCRETE:	61
PROBABILITY:	61
MARGINAL DISTRIBUTION:	61
EXPECTED VALUE:	61
INDEPENDENCE:	61
COVARIANCE:	62
5.17 MULTIVARIABLE CONTINUOUS:	62
PROBABILITY:	62
MARGINAL DISTRIBUTION:	62
EXPECTED VALUE:	62
INDEPENDENCE:	62
COVARIANCE:	62
CORRELATION COEFFICIENT:	62
ABBREVIATIONS	62

PART 6: FINANCIAL **64**

6.1 GENERAL FORMUALS:	64
PROFIT:	64
PROFIT MARGIN:	64
SIMPLE INTEREST:	64
COMPOUND INTEREST:	64
CONTINUOUS INTEREST:	64
ABBREVIATIONS (6.1):	64
6.2 MACROECONOMICS:	64
GDP:	64
RGDP:	64
NGDP:	64
GROWTH:	64
NET EXPORTS:	64
WORKING AGE POPULATION:	64
LABOR FORCE:	64
UNEMPLOYMENT:	64
NATURAL UNEMPLOYMENT:	64
UNEMPLOYMENT RATE:	64
EMPLOYMENT RATE:	64
PARTICIPATION RATE:	64
CPI:	64
INFLATION RATE:	64
ABBREVIATIONS (6.2)	64

PART 7: PI **66**

7.1 AREA:	66
CIRCLE:	66
CYCLIC QUADRILATERAL:	66
AREA OF A SECTOR (DEGREES)	66
AREA OF A SECTOR (RADIAN)	66
AREA OF A SEGMENT (DEGREES)	66
AREA OF AN ANNULUS:	66
ELLIPSE :	66
7.2 VOLUME:	66

SPHERE:	66
CAP OF A SPHERE:	66
CONE:	66
ICE-CREAM & CONE:	66
DOUGHNUT:	66
SAUSAGE:	66
ELLIPSOID:	66
7.3 SURFACE AREA:	66
SPHERE:	66
HEMISPHERE:	66
DOUGHNUT:	66
SAUSAGE:	66
CONE:	66
7.4 MISCELLANEOUS:	67
LENGTH OF ARC (DEGREES)	67
LENGTH OF CHORD (DEGREES)	67
PERIMETER OF AN ELLIPSE	67
7.6 PI:	67
JOHN WALLIS:	67
ISAAC NEWTON:	67
JAMES GREGORY:	67
LEONARD EULER:	67
JOZEF HOENE-WRONSKI:	67
FRANCISCUS VIETA:	67
INTEGRALS:	67
INFINITE SERIES:	68
CONTINUED FRACTIONS:	68
7.7 CIRCLE GEOMETRY:	69
RADIUS OF CIRCUMSCRIBED CIRCLE FOR RECTANGLES:	69
RADIUS OF CIRCUMSCRIBED CIRCLE FOR SQUARES:	69
RADIUS OF CIRCUMSCRIBED CIRCLE FOR TRIANGLES:	69
RADIUS OF CIRCUMSCRIBED CIRCLE FOR QUADRILATERALS:	69
RADIUS OF INSCRIBED CIRCLE FOR SQUARES:	69
RADIUS OF INSCRIBED CIRCLE FOR TRIANGLES:	69
RADIUS OF CIRCUMSCRIBED CIRCLE:	69
RADIUS OF INSCRIBED CIRCLE:	69
7.8 ABBREVIATIONS (7.1, 7.2, 7.3, 7.4, 7.5, 7.6, 7.7):	69
7.9 CRESCENT GEOMETRY:	70
AREA OF A LUNAR CRESCENT:	70
AREA OF AN ECLIPSE CRESCENT:	70
7.10 ABBREVIATIONS (7.9):	70
PART 8: PHYSICS	71
8.1 MOVEMENT:	71
STOPPING DISTANCE:	71
CENTRIPETAL ACCELERATION:	71
CENTRIPETAL FORCE:	71
DROPPING TIME :	71
FORCE:	71
KINETIC ENERGY:	71
MAXIMUM HEIGHT OF A CANNON:	71
PENDULUM SWING TIME:	71
POTENTIAL ENERGY:	71
RANGE OF A CANNON:	71

TIME IN FLIGHT OF A CANNON:	71
UNIVERSAL GRAVITATION:	71
ABBREVIATIONS (8.1):	71
8.2 CLASSICAL MECHANICS:	72
NEWTON'S LAWS:	72
INERTIA:	72
MOMENTS OF INERTIA:	73
VELOCITY AND SPEED:	76
ACCELERATION:	76
TRAJECTORY (DISPLACEMENT):	76
KINETIC ENERGY:	77
CENTRIPETAL FORCE:	77
CIRCULAR MOTION:	77
ANGULAR MOMENTUM:	77
TORQUE:	78
WORK:	78
LAWS OF CONSERVATION:	78
ABBREVIATIONS (8.2)	78
8.3 RELATIVISTIC EQUATIONS:	78
KINETIC ENERGY:	78
MOMENTUM:	79
TIME DILATION:	79
LENGTH CONTRACTION:	79
RELATIVISTIC MASS:	79

PART 9: TRIGONOMETRY **80**

9.1 CONVERSIONS:	80
9.2 BASIC RULES:	80
SIN RULE:	80
COS RULE:	80
TAN RULE:	80
AUXILIARY ANGLE:	80
PYTHAGORAS THEOREM:	80
9.3 RECIPROCAL FUNCTIONS	81
9.4 BASIC IDENTITIES:	81
9.5 IDENTITIES (SINθ):	81
9.6 IDENTITIES (COSθ):	82
9.7 IDENTITIES (TANθ):	82
9.8 IDENTITIES (CSCθ):	82
9.9 IDENTITIES (COTθ):	82
9.10 ADDITION FORMULAE:	83
9.11 DOUBLE ANGLE FORMULAE:	83
9.12 TRIPLE ANGLE FORMULAE:	84
9.13 HALF ANGLE FORMULAE:	84
9.14 POWER REDUCTION:	85
9.15 PRODUCT TO SUM:	86
9.16 SUM TO PRODUCT:	86
9.17 HYPERBOLIC EXPRESSIONS:	86
9.18 HYPERBOLIC RELATIONS:	87
9.19 MACHIN-LIKE FORMULAE:	87
FORM:	87
FORMULAE:	87
IDENTITIES:	88
9.20 SPHERICAL TRIANGLE IDENTITIES:	88

9.21 ABBREVIATIONS (9.1-9.19)	88
<u>PART 10: EXPONENTIALS & LOGARITHMS</u>	<u>90</u>
10.1 FUNDAMENTAL THEORY:	90
10.2 IDENTITIES:	90
10.3 CHANGE OF BASE:	90
10.4 LAWS FOR LOG TABLES:	90
10.5 COMPLEX NUMBERS:	91
10.6 LIMITS INVOLVING LOGARITHMIC TERMS	91
<u>PART 11: COMPLEX NUMBERS</u>	<u>92</u>
11.1 GENERAL:	92
FUNDAMENTAL:	92
STANDARD FORM:	92
POLAR FORM:	92
ARGUMENT:	92
MODULUS:	92
CONJUGATE:	92
EXPONENTIAL:	92
DE MOIVRE'S FORMULA:	92
EULER'S IDENTITY:	92
11.2 OPERATIONS:	92
ADDITION:	92
SUBTRACTION:	92
MULTIPLICATION:	92
DIVISION:	92
SUM OF SQUARES:	92
11.3 IDENTITIES:	92
EXPONENTIAL:	92
LOGARITHMIC:	92
TRIGONOMETRIC:	92
HYPERBOLIC:	93
<u>PART 12: DIFFERENTIATION</u>	<u>94</u>
12.1 GENERAL RULES:	94
PLUS OR MINUS:	94
PRODUCT RULE:	94
QUOTIENT RULE:	94
POWER RULE:	94
CHAIN RULE:	94
BLOB RULE:	94
BASE A LOG:	94
NATURAL LOG:	94
EXPONENTIAL (X):	94
FIRST PRINCIPLES:	94
12.2 EXPONENTIAL FUNCTIONS:	94
12.3 LOGARITHMIC FUNCTIONS:	95
12.4 TRIGONOMETRIC FUNCTIONS:	95
12.5 HYPERBOLIC FUNCTIONS:	95
12.5 PARTIAL DIFFERENTIATION:	96

FIRST PRINCIPLES:	96
GRADIENT:	96
TOTAL DIFFERENTIAL:	96
CHAIN RULE:	96
IMPLICIT DIFFERENTIATION:	97
HIGHER ORDER DERIVATIVES:	98

PART 13: INTEGRATION **99**

13.1 GENERAL RULES:	99
POWER RULE:	99
BY PARTS:	99
CONSTANTS:	99
13.2 RATIONAL FUNCTIONS:	99
13.3 TRIGONOMETRIC FUNCTIONS (SINE):	100
13.4 TRIGONOMETRIC FUNCTIONS (COSINE):	101
13.5 TRIGONOMETRIC FUNCTIONS (TANGENT):	102
13.6 TRIGONOMETRIC FUNCTIONS (SECANT):	102
13.7 TRIGONOMETRIC FUNCTIONS (COTANGENT):	103
13.8 TRIGONOMETRIC FUNCTIONS (SINE & COSINE):	103
13.9 TRIGONOMETRIC FUNCTIONS (SINE & TANGENT):	105
13.10 TRIGONOMETRIC FUNCTIONS (COSINE & TANGENT):	105
13.11 TRIGONOMETRIC FUNCTIONS (SINE & COTANGENT):	105
13.12 TRIGONOMETRIC FUNCTIONS (COSINE & COTANGENT):	105
13.13 TRIGONOMETRIC FUNCTIONS (ARCSINE):	105
13.14 TRIGONOMETRIC FUNCTIONS (ARCCOSINE):	106
13.15 TRIGONOMETRIC FUNCTIONS (ARCTANGENT):	106
13.16 TRIGONOMETRIC FUNCTIONS (ARCCOSECANT):	106
13.17 TRIGONOMETRIC FUNCTIONS (ARCSECANT):	107
13.18 TRIGONOMETRIC FUNCTIONS (ARCCOTANGENT):	107
13.19 EXPONENTIAL FUNCTIONS	107
13.20 LOGARITHMIC FUNCTIONS	109
13.21 HYPERBOLIC FUNCTIONS	111
13.22 INVERSE HYPERBOLIC FUNCTIONS	112
13.23 ABSOLUTE VALUE FUNCTIONS	113
13.24 SUMMARY TABLE	113
13.25 SQUARE ROOT PROOFS	114
13.26 CARTESIAN APPLICATIONS	117
AREA UNDER THE CURVE:	117
VOLUME:	117
VOLUME ABOUT X AXIS:	117
VOLUME ABOUT Y AXIS:	118
SURFACE AREA ABOUT X AXIS:	118
LENGTH WRT X-ORDINATES:	118
LENGTH WRT Y-ORDINATES:	118
LENGTH PARAMETRICALLY:	118

PART 14: FUNCTIONS **119**

14.1 COMPOSITE FUNCTIONS:	119
14.2 MULTIVARIABLE FUNCTIONS:	119
LIMIT:	119
DISCRIMINANT:	119
CRITICAL POINTS:	119

14.3 FIRST ORDER, FIRST DEGREE, DIFFERENTIAL EQUATIONS:	120
SEPARABLE	120
LINEAR	120
HOMOGENEOUS	120
EXACT	120
14.4 SECOND ORDER	121
HOMOGENEOUS	121
UNDETERMINED COEFFICIENTS	121
VARIATION OF PARAMETERS	121
PART 15: MATRICIES	123
15.1 BASIC PRINICIPLES:	123
SIZE	123
15.2 BASIC OPERTAIONS:	123
ADDITION:	123
SUBTRACTION:	123
SCALAR MULTIPLE:	123
TRANSPOSE:	123
SCALAR PRODUCT:	123
SYMMETRY:	123
CRAMER'S RULE:	123
LEAST SQUARES SOLUTION	123
15.3 SQUARE MATRIX:	123
DIAGONAL:	124
LOWER TRIANGLE MATRIX:	124
UPPER TRIANGLE MATRIX:	124
15.4 DETERMINATE:	124
2x2	124
3x3	124
NXN	124
RULES	124
15.5 INVERSE	126
2x2:	126
3x3:	126
MINOR:	126
COFACTOR:	127
ADJOINT METHOD FOR INVERSE:	127
LEFT INVERSE:	127
RIGHT INVERSE:	127
15.6 LINEAR TRANSFORMATION	127
AXIOMS FOR A LINEAR TRANSFORMATION:	127
TRANSITION MATRIX:	127
ZERO TRANSFORMATION:	128
IDENTITY TRANSFORMATION:	128
15.7 COMMON TRANSITION MATRICIES	128
ROTATION (CLOCKWISE):	128
ROTATION (ANTICLOCKWISE):	128
SCALING:	128
SHEARING (PARALLEL TO X-AXIS):	128
SHEARING (PARALLEL TO Y-AXIS):	128
15.8 EIGENVALUES AND EIGENVECTORS	128
DEFINITIONS:	128
EIGENVALUES:	128
EIGENVECTORS:	128

CHARACTERISTIC POLYNOMIAL:	128
ALGEBRAIC MULTIPLICITY:	128
GEOMETRIC MULTIPLICITY:	128
TRANSFORMATION:	129
LINEARLY INDEPENDENCE:	129
DIGITALIZATION:	129
CAYLEY-HAMILTON THEOREM:	129
ORTHONORMAL SET:	129
QR FACTORISATION:	129
15.9 JORDAN FORMS	130
GENERALISED DIAGONLISATION:	130
JORDAN BLOCK:	130
JORDAN FORM:	130
ALGEBRAIC MULTIPLICITY:	130
GEOMETRIC MULTIPLICITY:	130
GENERALISED CHAIN:	130
POWERS:	131
15.10 COMPLEX MATRICIS:	131
CONJUGATE TRANSPOSE:	131
HERMITIAN MATRIX:	131
SKEW-HERMITIAN:	131
UNITARY MATRIX:	131
NORMAL MATRIX:	131
DIAGONALISATION:	132
SPECTRAL THEOREM:	132
15.11 NUMERICAL COMPUTATIONS:	132
RAYLEIGH QUOTIENT:	132
POWER METHOD:	133

PART 16: VECTORS **135**

16.1 BASIC OPERATIONS:	135
ADDITION:	135
SUBTRACTION:	135
EQUALITY:	135
SCALAR MULTIPLICATION:	135
PARALLEL:	135
MAGNITUDE:	135
UNIT VECTOR:	135
ZERO VECTOR:	135
DOT PRODUCT:	135
ANGLE BETWEEN TWO VECTORS:	135
ANGLE OF A VECTOR IN 3D:	135
PERPENDICULAR TEST:	135
SCALAR PROJECTION:	136
VECTOR PROJECTION:	136
CROSS PRODUCT:	136
16.2 LINES	136
16.3 PLANES	136
16.4 CLOSEST APPROACH	136
TWO POINTS:	136
POINT AND LINE:	136
POINT AND PLANE:	136
TWO SKEW LINES:	137
16.5 GEOMETRY	137

AREA OF A TRIANGLE:	137
AREA OF A PARALLELOGRAM:	137
AREA OF A PARALLELEPIPED:	137
16.6 SPACE CURVES	137
WHERE:	137
VELOCITY:	137
ACCELERATION:	137
DEFINITION OF "S":	137
UNIT TANGENT:	137
CHAIN RULE:	137
NORMAL:	138
CURVATURE:	138
UNIT BINOMIAL:	138
TORTION:	138
16.7 VECTOR SPACE	138
16.8 ABBREVIATIONS	138
PART 17: SERIES	140
<hr/>	
17.1 MISCELLANEOUS	140
GENERAL FORM:	140
INFINITE FORM:	140
PARTIAL SUM OF A SERIES:	140
17.2 TEST FOR CONVERGENCE AND DIVERGENCE	140
TEST FOR CONVERGENCE:	140
TEST FOR DIVERGENCE:	140
GEOMETRIC SERIES	140
P SERIES	140
THE SANDWICH THEOREM	140
THE INTEGRAL TEST	140
THE DIRECT COMPARISON TEST	140
THE LIMIT COMPARISON TEST	141
D'ALMBERT'S RATIO COMPARISON TEST	141
THE N TH ROOT TEST	141
NEGATIVE TERMS	141
ALTERNATING SERIES TEST	141
ALTERNATING SERIES ERROR	141
17.3 ARITHMETIC PROGRESSION:	142
DEFINITION:	142
NTH TERM:	142
SUM OF THE FIRST N TERMS:	142
17.4 GEOMETRIC PROGRESSION:	142
DEFINITION:	142
NTH TERM:	142
SUM OF THE FIRST N TERMS:	142
SUM TO INFINITY:	142
GEOMETRIC MEAN:	142
17.5 SUMMATION SERIES	142
LINEAR:	142
QUADRATIC:	142
CUBIC:	142
17.6 APPROXIMATION SERIES	142
TAYLOR SERIES	142
MACLAURUN SERIES	142
LINEAR APPROXIMATION:	143

QUADRATIC APPROXIMATION:	143
CUBIC APPROXIMATION:	143
17.7 MONOTONE SERIES	143
STRICTLY INCREASING:	143
NON-DECREASING:	143
STRICTLY DECREASING:	143
NON-INCREASING:	143
CONVERGENCE:	143
17.8 RIEMANN ZETA FUNCTION	143
FORM:	143
EULER'S TABLE:	143
ALTERNATING SERIES:	144
PROOF FOR N=2:	144
17.9 SUMMATIONS OF POLYNOMIAL EXPRESSIONS	145
17.10 SUMMATIONS INVOLVING EXPONENTIAL TERMS	145
17.11 SUMMATIONS INVOLVING TRIGONOMETRIC TERMS	146
17.12 INFINITE SUMMATIONS TO PI	148
17.13 LIMITS INVOLVING TRIGONOMETRIC TERMS	148
ABBREVIATIONS	148
17.14 POWER SERIES EXPANSION	148
EXPONENTIAL:	148
TRIGONOMETRIC:	149
EXPONENTIAL AND LOGARITHM SERIES:	151
FOURIER SERIES:	152
17.15 BERNOULLI EXPANSION:	152
FUNDAMENTALLY:	152
EXPANSIONS:	153
LIST OF BERNOULLI NUMBERS:	153
<u>PART 18: ELECTRICAL</u>	<u>155</u>
18.1 FUNDAMENTAL THEORY	155
CHARGE:	155
CURRENT:	155
RESISTANCE:	155
OHM'S LAW:	155
POWER:	155
CONSERVATION OF POWER:	155
ELECTRICAL ENERGY:	155
KIRCHOFF'S VOLTAGE LAW:	155
KIRCHOFF'S CURRENT LAW:	155
AVERAGE CURRENT:	155
RMS CURRENT:	155
Δ TO Y CONVERSION:	155
18.2 COMPONENTS	156
RESISTANCE IN SERIES:	156
RESISTANCE IN PARALLEL:	156
INDUCTIVE IMPEDANCE:	156
CAPACITOR IMPEDANCE:	156
CAPACITANCE IN SERIES:	156
CAPACITANCE IN PARALLEL:	156
VOLTAGE, CURRENT & POWER SUMMARY:	156
18.3 THEVENIN'S THEOREM	156
THEVENIN'S THEOREM:	156
MAXIMUM POWER TRANSFER THEOREM:	157

18.4 FIRST ORDER RC CIRCUIT	157
18.5 FIRST ORDER RL CIRCUIT	157
18.6 SECOND ORDER RLC SERIES CIRCUIT	157
CALCULATION USING KVL:	157
IMPORTANT VARIABLES	157
SOLVING:	158
MODE 1:	158
MODE 2:	158
MODE 3:	159
MODE 4:	159
CURRENT THROUGH INDUCTOR:	160
PLOTTING MODES:	160
18.7 SECOND ORDER RLC PARALLEL CIRCUIT	161
CALCULATION USING KCL:	161
IMPORTANT VARIABLES	161
SOLVING:	162
18.8 LAPLANCE TRANSFORMATIONS	162
IDENTITIES:	162
PROPERTIES:	163
18.9 THREE PHASE – Y	164
LINE VOLTAGE:	164
PHASE VOLTAGE:	164
LINE CURRENT:	164
PHASE CURRENT:	164
POWER:	164
18.10 THREE PHASE – DELTA	164
LINE VOLTAGE:	164
PHASE VOLTAGE:	164
LINE CURRENT:	164
PHASE CURRENT:	164
POWER:	164
18.11 POWER	164
INSTANTANEOUS:	164
AVERAGE:	165
MAXIMUM POWER:	165
TOTAL POWER:	165
COMPLEX POWER:	165
18.12 ELECTROMAGNETICS	165
DEFINITIONS:	165
PERMEABILITY OF FREE SPACE:	165
MAGNETIC FIELD INTENSITY:	165
RELUCTANCE:	165
OHM’S LAW:	165
MAGNETIC FORCE ON A CONDUCTOR:	165
ELECTROMAGNETIC INDUCTION:	165
MAGNETIC FLUX:	165
ELECTRIC FIELD:	165
MAGNETIC FORCE ON A PARTICLE:	165
<u>PART 19: GRAPH THEORY</u>	<u>166</u>
19.1 FUNDAMENTAL EXPLANATIONS	166
LIST OF VERTICES:	166
LIST OF EDGES:	166
SUBGAPHS:	166

DEGREE OF VERTEX:	166
DISTANCE:	166
DIAMETER:	166
TOTAL EDGES IN A SIMPLE BIPARTITE GRAPH:	166
TOTAL EDGES IN K-REGULAR GRAPH:	166
19.2 FACTORISATION:	166
1 FACTORISATION:	166
1 FACTORS OF A $K_{n,n}$ BIPARTITE GRAPH:	166
1 FACTORS OF A K_{2n} GRAPH:	166
19.3 VERTEX COLOURING	166
CHROMATIC NUMBER:	167
UNION/INTERSECTION:	167
EDGE CONTRACTION:	167
COMMON CHROMATIC POLYNOMIALS:	167
19.4 EDGE COLOURING:	167
COMMON CHROMATIC POLYNOMIALS:	167

PART 98: LIST OF DISTRIBUTION FUNCTIONS **168**

5.18 FINITE DISCRETE DISTRIBUTIONS	168
BERNOULLI DISTRIBUTION	168
RADEMACHER DISTRIBUTION	168
BINOMIAL DISTRIBUTION	169
BETA-BINOMIAL DISTRIBUTION	170
DEGENERATE DISTRIBUTION	171
DISCRETE UNIFORM DISTRIBUTION	172
HYPERGEOMETRIC DISTRIBUTION	174
POISSON BINOMIAL DISTRIBUTION	175
FISHER'S NONCENTRAL HYPERGEOMETRIC DISTRIBUTION (UNIVARIATE)	175
FISHER'S NONCENTRAL HYPERGEOMETRIC DISTRIBUTION (MULTIVARIATE)	176
WALLENIUS' NONCENTRAL HYPERGEOMETRIC DISTRIBUTION (UNIVARIATE)	176
WALLENIUS' NONCENTRAL HYPERGEOMETRIC DISTRIBUTION (MULTIVARIATE)	177
5.19 INFINITE DISCRETE DISTRIBUTIONS	177
BETA NEGATIVE BINOMIAL DISTRIBUTION	177
MAXWELL–BOLTZMANN DISTRIBUTION	178
GEOMETRIC DISTRIBUTION	179
LOGARITHMIC (SERIES) DISTRIBUTION	181
NEGATIVE BINOMIAL DISTRIBUTION	182
POISSON DISTRIBUTION	183
CONWAY–MAXWELL–POISSON DISTRIBUTION	184
SKELLAM DISTRIBUTION	185
YULE–SIMON DISTRIBUTION	185
ZETA DISTRIBUTION	187
ZIPF'S LAW	188
ZIPF–MANDELBROT LAW	189
5.20 BOUNDED INFINITE DISTRIBUTIONS	189
ARCSINE DISTRIBUTION	189
BETA DISTRIBUTION	191
LOGITNORMAL DISTRIBUTION	193
CONTINUOUS UNIFORM DISTRIBUTION	194
IRWIN-HALL DISTRIBUTION	195
KUMARASWAMY DISTRIBUTION	196
RAISED COSINE DISTRIBUTION	197
TRIANGULAR DISTRIBUTION	198

TRUNCATED NORMAL DISTRIBUTION	200
U-QUADRATIC DISTRIBUTION	201
VON MISES DISTRIBUTION	202
WIGNER SEMICIRCLE DISTRIBUTION	203
5.21 SEMI-BOUNDED CUMULATIVE DISTRIBUTIONS	205
BETA PRIME DISTRIBUTION	205
CHI DISTRIBUTION	206
NONCENTRAL CHI DISTRIBUTION	207
CHI-SQUARED DISTRIBUTION	207
INVERSE-CHI-SQUARED DISTRIBUTION	208
NONCENTRAL CHI-SQUARED DISTRIBUTION	210
SCALED-INVERSE-CHI-SQUARED DISTRIBUTION	211
DAGUM DISTRIBUTION	212
EXPONENTIAL DISTRIBUTION	213
FISHER'S Z-DISTRIBUTION	216
FOLDED NORMAL DISTRIBUTION	216
FRÉCHET DISTRIBUTION	217
GAMMA DISTRIBUTION	218
ERLANG DISTRIBUTION	219
INVERSE-GAMMA DISTRIBUTION	220
INVERSE GAUSSIAN/WALD DISTRIBUTION	221
LÉVY DISTRIBUTION	222
LOG-CAUCHY DISTRIBUTION	224
LOG-LOGISTIC DISTRIBUTION	225
LOG-NORMAL DISTRIBUTION	226
MITTAG–LEFFLER DISTRIBUTION	227
PARETO DISTRIBUTION	228
RAYLEIGH DISTRIBUTION	229
RICE DISTRIBUTION	230
TYPE-2 GUMBEL DISTRIBUTION	231
WEIBULL DISTRIBUTION	232
5.22 UNBOUNDED CUMULATIVE DISTRIBUTIONS	233
CAUCHY DISTRIBUTION	233
EXPONENTIALLY MODIFIED GAUSSIAN DISTRIBUTION	234
FISHER–TIPPETT/ GENERALIZED EXTREME VALUE DISTRIBUTION	236
GUMBEL DISTRIBUTION	237
FISHER'S Z-DISTRIBUTION	238
GENERALIZED NORMAL DISTRIBUTION	238
GEOMETRIC STABLE DISTRIBUTION	240
HOLTSMARK DISTRIBUTION	240
HYPERBOLIC DISTRIBUTION	241
HYPERBOLIC SECANT DISTRIBUTION	242
LAPLACE DISTRIBUTION	243
LÉVY SKEW ALPHA-STABLE DISTRIBUTION	244
LINNIK DISTRIBUTION	246
LOGISTIC DISTRIBUTION	246
NORMAL DISTRIBUTION	248
NORMAL-EXPONENTIAL-GAMMA DISTRIBUTION	249
SKEW NORMAL DISTRIBUTION	249
STUDENT'S T-DISTRIBUTION	250
NONCENTRAL T-DISTRIBUTION	252
VOIGT DISTRIBUTION	252
GENERALIZED PARETO DISTRIBUTION	253
TUKEY LAMBDA DISTRIBUTION	254
5.23 JOINT DISTRIBUTIONS	254
DIRICHLET DISTRIBUTION	254

BALDING–NICHOLS MODEL	255
MULTINOMIAL DISTRIBUTION	256
MULTIVARIATE NORMAL DISTRIBUTION	256
NEGATIVE MULTINOMIAL DISTRIBUTION	257
WISHART DISTRIBUTION	258
INVERSE-WISHART DISTRIBUTION	258
MATRIX NORMAL DISTRIBUTION	258
MATRIX T-DISTRIBUTION	259
5.24 OTHER DISTRIBUTIONS	259
CATEGORICAL DISTRIBUTION	259
CANTOR DISTRIBUTION	260
PHASE-TYPE DISTRIBUTION	261
TRUNCATED DISTRIBUTION	261

PART 99: CONVERSIONS **263**

99.1 LENGTH:	263
99.2 AREA:	265
99.3 VOLUME:	266
99.4 PLANE ANGLE:	270
99.5 SOLID ANGLE:	270
99.6 MASS:	270
99.7 DENSITY:	272
99.8 TIME:	273
99.9 FREQUENCY:	274
99.10 SPEED OR VELOCITY:	274
99.11 FLOW (VOLUME):	275
99.12 ACCELERATION:	276
99.13 FORCE:	276
99.14 PRESSURE OR MECHANICAL STRESS:	277
99.15 TORQUE OR MOMENT OF FORCE:	278
99.16 ENERGY, WORK, OR AMOUNT OF HEAT:	278
99.17 POWER OR HEAT FLOW RATE:	280
99.18 ACTION:	281
99.19 DYNAMIC VISCOSITY:	281
99.20 KINEMATIC VISCOSITY:	281
99.21 ELECTRIC CURRENT:	281
99.22 ELECTRIC CHARGE:	282
99.23 ELECTRIC DIPOLE:	282
99.24 ELECTROMOTIVE FORCE, ELECTRIC POTENTIAL DIFFERENCE:	282
99.25 ELECTRICAL RESISTANCE:	283
99.26 CAPACITANCE:	283
99.27 MAGNETIC FLUX:	283
99.28 MAGNETIC FLUX DENSITY:	283
99.29 INDUCTANCE:	283
99.30 TEMPERATURE:	283
99.31 INFORMATION ENTROPY:	284
99.32 LUMINOUS INTENSITY:	284
99.33 LUMINANCE:	285
99.34 LUMINOUS FLUX:	285
99.35 ILLUMINANCE:	285
99.36 RADIATION - SOURCE ACTIVITY:	285
99.37 RADIATION – EXPOSURE:	285
99.38 RADIATION - ABSORBED DOSE:	285
99.39 RADIATION - EQUIVALENT DOSE:	286

PART 1: PHYSICAL CONSTANTS

1.1 SI PREFIXES:

Prefix	Symbol	1000^m	10^n	Decimal	Scale
yotta	Y	1000^8	10^{24}	1000000000000000000000000	Septillion
zetta	Z	1000^7	10^{21}	100000000000000000000000	Sextillion
exa	E	1000^6	10^{18}	100000000000000000000000	Quintillion
peta	P	1000^5	10^{15}	100000000000000000000000	Quadrillion
tera	T	1000^4	10^{12}	100000000000000000000000	Trillion
giga	G	1000^3	10^9	100000000000000000000000	Billion
mega	M	1000^2	10^6	100000000000000000000000	Million
kilo	k	1000^1	10^3	100000000000000000000000	Thousand
hecto	h	$1000^{2/3}$	10^2	100000000000000000000000	Hundred
deca	da	$1000^{1/3}$	10^1	100000000000000000000000	Ten
		1000^0	10^0	100000000000000000000000	One
deci	d	$1000^{-1/3}$	10^{-1}	100000000000000000000000	Tenth
centi	c	$1000^{-2/3}$	10^{-2}	100000000000000000000000	Hundredth
milli	m	1000^{-1}	10^{-3}	100000000000000000000000	Thousandth
micro	μ	1000^{-2}	10^{-6}	100000000000000000000000	Millionth
nano	n	1000^{-3}	10^{-9}	100000000000000000000000	Billionth
pico	p	1000^{-4}	10^{-12}	100000000000000000000000	Trillionth
femto	f	1000^{-5}	10^{-15}	100000000000000000000000	Quadrillionth
atto	a	1000^{-6}	10^{-18}	100000000000000000000000	Quintillionth
zepto	z	1000^{-7}	10^{-21}	100000000000000000000000	Sextillionth
yocto	y	1000^{-8}	10^{-24}	100000000000000000000000	Septillionth

1.2 SI BASE UNITS:

Quantity	Unit	Symbol
length	meter	m
mass	kilogram	kg
time	second	s
electric current	ampere	A
thermodynamic temperature	kelvin	K
amount of substance	mole	mol
luminous intensity	candela	cd

1.3 SI DERIVED UNITS:

Quantity	Unit	Symbol	Expression in terms of other SI units
angle, plane	radian*	rad	$m/m = 1$
angle, solid	steradian*	sr	$m^2/m^2 = 1$
Celsius temperature	degree Celsius	°C	K
electric capacitance	farad	F	C/V
electric charge, quantity of electricity	coulomb	C	A·s
electric conductance	siemens	S	A/V
electric inductance	henry	H	Wb/A
electric potential difference, electromotive force	volt	V	W/A
electric resistance	ohm	Ω	V/A
energy, work, quantity of heat	joule	J	N·m
force	newton	N	$kg \cdot m/s^2$
frequency (of a periodic phenomenon)	hertz	Hz	1/s
illuminance	lux	lx	lm/m^2
luminous flux	lumen	lm	cd·sr
magnetic flux	weber	Wb	V·s
magnetic flux density	tesla	T	Wb/m^2
power, radiant flux	watt	W	J/s
pressure, stress	pascal	Pa	N/m^2
activity (referred to a radionuclide)	becquerel	Bq	1/s
absorbed dose, specific energy imparted, kerma	gray	Gy	J/kg
dose equivalent, ambient dose equivalent, directional dose equivalent, personal dose equivalent, organ dose equivalent	sievert	Sv	J/kg
catalytic activity	katal	kat	mol/s

1.4 UNIVERSAL CONSTANTS:

Quantity	Symbol	Value	Relative Standard Uncertainty
speed of light in vacuum	c	299 792 458 m·s ⁻¹	defined
Newtonian constant of gravitation	G	6.67428(67)×10 ⁻¹¹ m ³ ·kg ⁻¹ ·s ⁻²	1.0 × 10 ⁻⁴
Planck constant	h	6.626 068 96(33) × 10 ⁻³⁴ J·s	5.0 × 10 ⁻⁸
reduced Planck constant	$\hbar = h/(2\pi)$	1.054 571 628(53) × 10 ⁻³⁴ J·s	5.0 × 10 ⁻⁸

1.5 ELECTROMAGNETIC CONSTANTS:

Quantity	Symbol	Value (SI units)	Relative Standard Uncertainty
magnetic constant (vacuum permeability)	μ_0	4π × 10 ⁻⁷ N·A ⁻² = 1.256 637 061... × 10 ⁻⁶ N·A ⁻²	defined
electric constant (vacuum permittivity)	$\epsilon_0 = 1/(\mu_0 c^2)$	8.854 187 817... × 10 ⁻¹² F·m ⁻¹	defined
characteristic impedance of vacuum	$Z_0 = \mu_0 c$	376.730 313 461... Ω	defined
Coulomb's constant	$k_e = 1/4\pi\epsilon_0$	8.987 551 787... × 10 ⁹ N·m ² ·C ⁻²	defined
elementary charge	e	1.602 176 487(40) × 10 ⁻¹⁹ C	2.5 × 10 ⁻⁸
Bohr magneton	$\mu_B = e\hbar/2m_e$	927.400 915(23) × 10 ⁻²⁶ J·T ⁻¹	2.5 × 10 ⁻⁸
conductance quantum	$G_0 = 2e^2/h$	7.748 091 7004(53) × 10 ⁻⁵ S	6.8 × 10 ⁻¹⁰
inverse conductance quantum	$G_0^{-1} = h/2e^2$	12 906.403 7787(88) Ω	6.8 × 10 ⁻¹⁰
Josephson constant	$K_J = 2e/h$	4.835 978 91(12) × 10 ¹⁴ Hz·V ⁻¹	2.5 × 10 ⁻⁸
magnetic flux quantum	$\phi_0 = h/2e$	2.067 833 667(52) × 10 ⁻¹⁵ Wb	2.5 × 10 ⁻⁸
nuclear magneton	$\mu_N = e\hbar/2m_p$	5.050 783 43(43) × 10 ⁻²⁷ J·T ⁻¹	8.6 × 10 ⁻⁸
von Klitzing constant	$R_K = h/e^2$	25 812.807 557(18) Ω	6.8 × 10 ⁻¹⁰

1.6 ATOMIC AND NUCLEAR CONSTANTS:

Quantity	Symbol	Value (SI units)	Relative Standard Uncertainty
Bohr radius	$a_0 = \alpha/4\pi R_\infty$	5.291 772 108(18) \times 10^{-11} m	3.3×10^{-9}
classical electron radius	$r_e = e^2/4\pi\epsilon_0 m_e c^2$	2.817 940 2894(58) \times 10^{-15} m	2.1×10^{-9}
electron mass	m_e	9.109 382 15(45) $\times 10^{-31}$ kg	5.0×10^{-8}
Fermi coupling constant	$G_F/(\hbar c)^3$	1.166 39(1) \times 10^{-5} GeV ⁻²	8.6×10^{-6}
fine-structure constant	$\alpha = \mu_0 e^2 c/(2h) = e^2/(4\pi\epsilon_0 \hbar c)$	7.297 352 537 6(50) $\times 10^{-3}$	6.8×10^{-10}
Hartree energy	$E_h = 2R_\infty hc$	4.359 744 17(75) $\times 10^{-18}$ J	1.7×10^{-7}
proton mass	m_p	1.672 621 637(83) \times 10^{-27} kg	5.0×10^{-8}
quantum of circulation	$h/2m_e$	3.636 947 550(24) $\times 10^{-4}$ m ² s ⁻¹	6.7×10^{-9}
Rydberg constant	$R_\infty = \alpha^2 m_e c/2h$	10 973 731.568 525(73) m ⁻¹	6.6×10^{-12}
Thomson cross section	$(8\pi/3)r_e^2$	6.652 458 73(13) $\times 10^{-29}$ m ²	2.0×10^{-8}
weak mixing angle	$\sin^2 \theta_W = 1 - (m_W/m_Z)^2$	0.222 15(76)	3.4×10^{-3}

1.7 PHYSICO-CHEMICAL CONSTANTS:

Quantity	Symbol	Value (SI units)	Relative Standard Uncertainty
atomic mass unit (unified atomic mass unit)	$m_u = 1 u$	1.660 538 86(28) \times 10^{-27} kg	1.7×10^{-7}
Avogadro's number	N_A, L	6.022 141 5(10) \times 10^{23} mol ⁻¹	1.7×10^{-7}
Boltzmann constant	$k = k_B = R/N_A$	1.380 6504(24) \times	1.8×10^{-6}

			$10^{-23} \text{ J}\cdot\text{K}^{-1}$	
Faraday constant	$F = N_A e$		96 $485.3383(83) \text{ C}\cdot\text{mol}^{-1}$	8.6×10^{-8}
first radiation constant		$c_1 = 2\pi h c^2$	$3.741\,771\,18(19) \times 10^{-16} \text{ W}\cdot\text{m}^2$	5.0×10^{-8}
	for spectral radiance	c_{1L}	$1.191\,042\,82(20) \times 10^{-16} \text{ W}\cdot\text{m}^2 \text{ sr}^{-1}$	1.7×10^{-7}
Loschmidt constant	at $T=273.15 \text{ K}$ and $p=101.325 \text{ kPa}$	$n_0 = N_A/V_m$	$2.686\,777\,3(47) \times 10^{25} \text{ m}^{-3}$	1.8×10^{-6}
gas constant		R	$8.314\,472(15) \text{ J}\cdot\text{K}^{-1}\cdot\text{mol}^{-1}$	1.7×10^{-6}
molar Planck constant		$N_A h$	$3.990\,312\,716(27) \times 10^{-10} \text{ J}\cdot\text{s}\cdot\text{mol}^{-1}$	6.7×10^{-9}
molar volume of an ideal gas	at $T=273.15 \text{ K}$ and $p=100 \text{ kPa}$	$V_m = RT/p$	$2.2710\,981(40) \times 10^{-2} \text{ m}^3\cdot\text{mol}^{-1}$	1.7×10^{-6}
	at $T=273.15 \text{ K}$ and $p=101.325 \text{ kPa}$		$2.2413\,996(39) \times 10^{-2} \text{ m}^3\cdot\text{mol}^{-1}$	1.7×10^{-6}
Sackur-Tetrode constant	at $T=1 \text{ K}$ and $p=100 \text{ kPa}$	$S_0/R = \frac{5}{2} + \ln \left[(2\pi m_u kT/h^2)^{3/2} kT/p \right]$	$-1.151\,704\,7(44)$	3.8×10^{-6}
	at $T=1 \text{ K}$ and $p=101.325 \text{ kPa}$		$-1.164\,867\,7(44)$	3.8×10^{-6}
second radiation constant		$c_2 = hc/k$	$1.438\,775\,2(25) \times 10^{-2} \text{ m}\cdot\text{K}$	1.7×10^{-6}
Stefan–Boltzmann constant		$\sigma = (\pi^2/60)k^4/\hbar^3 c^2$	$5.670\,400(40) \times 10^{-8} \text{ W}\cdot\text{m}^{-2}\cdot\text{K}^{-4}$	7.0×10^{-6}
Wien displacement law constant		$b = (hc/k)/4.965\,114\,231\dots$	$2.897\,768\,5(51) \times 10^{-3} \text{ m}\cdot\text{K}$	1.7×10^{-6}

1.8 ADOPTED VALUES:

Quantity	Symbol	Value (SI units)	Relative Standard Uncertainty
conventional value of	K_{J-90}	$4.835\,979 \times$	defined

Josephson constant		$10^{14} \text{ Hz}\cdot\text{V}^{-1}$	
conventional value of von Klitzing constant	R_{K-90}	$25\,812.807 \Omega$	defined
molar mass	constant	$M_u = M(^{12}\text{C})/12$	$1 \times 10^{-3} \text{ kg}\cdot\text{mol}^{-1}$ defined
	of carbon-12	$M(^{12}\text{C}) = N_A m(^{12}\text{C})$	$1.2 \times 10^{-2} \text{ kg}\cdot\text{mol}^{-1}$ defined
standard acceleration of gravity (gee, free-fall on Earth)	g_n	$9.806\,65 \text{ m}\cdot\text{s}^{-2}$	defined
standard atmosphere	atm	101 325 Pa	defined

1.9 NATURAL UNITS:

Name	Dimension	Expression	Value (SI units)
Planck length	Length (L)	$l_P = \sqrt{\frac{\hbar G}{c^3}}$	$1.616\,252(81) \times 10^{-35} \text{ m}$
Planck mass	Mass (M)	$m_P = \sqrt{\frac{\hbar c}{G}}$	$2.176\,44(11) \times 10^{-8} \text{ kg}$
Planck time	Time (T)	$t_P = \sqrt{\frac{\hbar G}{c^5}}$	$5.391\,24(27) \times 10^{-44} \text{ s}$
Planck charge	Electric charge (Q)	$q_P = \sqrt{4\pi\epsilon_0\hbar c}$	$1.875\,545\,870(47) \times 10^{-18} \text{ C}$
Planck temperature	Temperature (Θ)	$T_P = \sqrt{\frac{\hbar c^5}{Gk^2}}$	$1.416\,785(71) \times 10^{32} \text{ K}$

PART 2: MATHEMATICAL SYMBOLS

2.1 BASIC MATH SYMBOLS

Symbol	Symbol Name	Meaning / definition	Example
=	equals sign	equality	$5 = 2+3$
≠	not equal sign	inequality	$5 \neq 4$
>	strict inequality	greater than	$5 > 4$
<	strict inequality	less than	$4 < 5$
≥	inequality	greater than or equal to	$5 \geq 4$
≤	inequality	less than or equal to	$4 \leq 5$
()	parentheses	calculate expression inside first	$2 \times (3+5) = 16$
[]	brackets	calculate expression inside first	$[(1+2) \cdot (1+5)] = 18$
+	plus sign	addition	$1 + 1 = 2$
-	minus sign	subtraction	$2 - 1 = 1$
±	plus - minus	both plus and minus operations	$3 \pm 5 = 8 \text{ and } -2$
∓	minus - plus	both minus and plus operations	$3 \mp 5 = -2 \text{ and } 8$
*	asterisk	multiplication	$2 * 3 = 6$
×	times sign	multiplication	$2 \times 3 = 6$
·	multiplication dot	multiplication	$2 \cdot 3 = 6$
÷	division sign / obelus	division	$6 \div 2 = 3$
/	division slash	division	$6 / 2 = 3$
-	horizontal line	division / fraction	$\frac{6}{2} = 3$
mod	modulo	remainder calculation	$7 \bmod 2 = 1$
.	period	decimal point, decimal separator	$2.56 = 2+56/100$
a^b	power	exponent	$2^3 = 8$
$a^{\wedge}b$	caret	exponent	$2 \wedge 3 = 8$
\sqrt{a}	square root	$\sqrt{a} \cdot \sqrt{a} = a$	$\sqrt{9} = \pm 3$
$\sqrt[3]{a}$	cube root		$\sqrt[3]{8} = 2$
$\sqrt[4]{a}$	fourth root		$\sqrt[4]{16} = \pm 2$
$\sqrt[n]{a}$	n-th root (radical)		for $n=3$, $\sqrt[n]{8} = 2$
%	percent	$1\% = 1/100$	$10\% \times 30 = 3$
‰	per-mille	$1\text{‰} = 1/1000 = 0.1\%$	$10\text{‰} \times 30 = 0.3$
ppm	per-million	$1\text{ppm} = 1/1000000$	$10\text{ppm} \times 30 = 0.0003$
ppb	per-billion	$1\text{ppb} = 1/1000000000$	$10\text{ppb} \times 30 = 3 \times 10^{-7}$
ppt	per-trillion	$1\text{ppt} = 10^{-12}$	$10\text{ppt} \times 30 = 3 \times 10^{-10}$

2.2 GEOMETRY SYMBOLS

Symbol	Symbol Name	Meaning / definition	Example
∠	angle	formed by two rays	$\angle ABC = 30^\circ$
∠̂	measured angle		$\hat{\angle} ABC = 30^\circ$
∠̂	spherical angle		$\hat{\sphericalangle} AOB = 30^\circ$
⊥	right angle	$= 90^\circ$	$\alpha = 90^\circ$
°	degree	1 turn = 360°	$\alpha = 60^\circ$
′	arcminute	$1^\circ = 60′$	$\alpha = 60^\circ 59′$

''	arcsecond	1' = 60''	$\alpha = 60^{\circ}59'59''$
AB	line	line from point A to point B	
\overrightarrow{AB}	ray	line that start from point A	
\perp	perpendicular	perpendicular lines (90° angle)	$AC \perp BC$
	parallel	parallel lines	$AB \parallel CD$
\cong	congruent to	equivalence of geometric shapes and size	$\triangle ABC \cong \triangle XYZ$
\sim	similarity	same shapes, not same size	$\triangle ABC \sim \triangle XYZ$
Δ	triangle	triangle shape	$\triangle ABC \cong \triangle BCD$
x-y	distance	distance between points x and y	$ x-y = 5$
π	pi constant	$\pi = 3.141592654\dots$ is the ratio between the circumference and diameter of a circle	$c = \pi \cdot d = 2 \cdot \pi \cdot r$
rad	radians	radians angle unit	$360^{\circ} = 2\pi \text{ rad}$
grad	grads	grads angle unit	$360^{\circ} = 400 \text{ grad}$

2.3 ALGEBRA SYMBOLS

Symbol	Symbol Name	Meaning / definition	Example
x	x variable	unknown value to find	when $2x = 4$, then $x = 2$
\equiv	equivalence	identical to	
\triangleq	equal by definition	equal by definition	
$:=$	equal by definition	equal by definition	
\sim	approximately equal	weak approximation	$11 \sim 10$
\approx	approximately equal	approximation	$\sin(0.01) \approx 0.01$
\propto	proportional to	proportional to	$f(x) \propto g(x)$
∞	lemniscate	infinity symbol	
\ll	much less than	much less than	$1 \ll 1000000$
\gg	much greater than	much greater than	$1000000 \gg 1$
()	parentheses	calculate expression inside first	$2 * (3+5) = 16$
[]	brackets	calculate expression inside first	$[(1+2)*(1+5)] = 18$
{ }	braces	set	
$\lfloor x \rfloor$	floor brackets	rounds number to lower integer	$\lfloor 4.3 \rfloor = 4$
$\lceil x \rceil$	ceiling brackets	rounds number to upper integer	$\lceil 4.3 \rceil = 5$
$x!$	exclamation mark	factorial	$4! = 1*2*3*4 = 24$
$ x $	single vertical bar	absolute value	$ -5 = 5$
$f(x)$	function of x	maps values of x to f(x)	$f(x) = 3x+5$
$(f \circ g)$	function composition	$(f \circ g)(x) = f(g(x))$	$f(x)=3x, g(x)=x-1 \Rightarrow (f \circ g)(x)=3(x-1)$
(a,b)	open interval	$(a,b) \triangleq \{x \mid a < x < b\}$	$x \in (2,6)$
$[a,b]$	closed interval	$[a,b] \triangleq \{x \mid a \leq x \leq b\}$	$x \in [2,6]$
Δ	delta	change / difference	$\Delta t = t_1 - t_0$
Δ	discriminant	$\Delta = b^2 - 4ac$	
\sum	sigma	summation - sum of all values in range of series	$\sum x_i = x_1 + x_2 + \dots + x_n$

$\Sigma\Sigma$	sigma	double summation	$\sum_{j=1}^2 \sum_{i=1}^8 x_{i,j} = \sum_{i=1}^8 x_{i,1} + \sum_{i=1}^8 x_{i,2}$
Π	capital pi	product - product of all values in range of series	$\prod x_i = x_1 \cdot x_2 \cdot \dots \cdot x_n$
e	e constant / Euler's number	$e = 2.718281828\dots$	$e = \lim (1+1/x)^x, x \rightarrow \infty$
γ	Euler-Mascheroni constant	$\gamma = 0.527721566\dots$	
φ	golden ratio	golden ratio constant	

2.4 LINEAR ALGEBRA SYMBOLS

Symbol	Symbol Name	Meaning / definition	Example
\cdot	dot	scalar product	$a \cdot b$
\times	cross	vector product	$a \times b$
$A \otimes B$	tensor product	tensor product of A and B	$A \otimes B$
$\langle x, y \rangle$	inner product		
[]	brackets	matrix of numbers	
()	parentheses	matrix of numbers	
A	determinant	determinant of matrix A	
det(A)	determinant	determinant of matrix A	
$\ x \ $	double vertical bars	norm	
A^T	transpose	matrix transpose	$(A^T)_{ij} = (A)_{ji}$
A^\dagger	Hermitian matrix	matrix conjugate transpose	$(A^\dagger)_{ij} = (A)_{ji}$
A^*	Hermitian matrix	matrix conjugate transpose	$(A^*)_{ij} = (A)_{ji}$
A^{-1}	inverse matrix	$A A^{-1} = I$	
rank(A)	matrix rank	rank of matrix A	rank(A) = 3
dim(U)	dimension	dimension of matrix A	rank(U) = 3

2.5 PROBABILITY AND STATISTICS SYMBOLS

Symbol	Symbol Name	Meaning / definition	Example
$P(A)$	probability function	probability of event A	$P(A) = 0.5$
$P(A \cap B)$	probability of events intersection	probability that of events A and B	$P(A \cap B) = 0.5$
$P(A \cup B)$	probability of events union	probability that of events A or B	$P(A \cup B) = 0.5$
$P(A B)$	conditional probability function	probability of event A given event B occurred	$P(A B) = 0.3$
$f(x)$	probability density function (pdf)	$P(a \leq x \leq b) = \int f(x) dx$	
$F(x)$	cumulative distribution function (cdf)	$F(x) = P(X \leq x)$	
μ	population mean	mean of population values	$\mu = 10$
$E(X)$	expectation value	expected value of random variable X	$E(X) = 10$
$E(X / Y)$	conditional expectation	expected value of random variable X given Y	$E(X / Y=2) = 5$

$var(X)$	variance	variance of random variable X	$var(X) = 4$
σ^2	variance	variance of population values	$\sigma^2 = 4$
$std(X)$	standard deviation	standard deviation of random variable X	$std(X) = 2$
σ_x	standard deviation	standard deviation value of random variable X	$\sigma_x = 2$
\tilde{x}	median	middle value of random variable x	$\tilde{x} = 5$
$cov(X,Y)$	covariance	covariance of random variables X and Y	$cov(X,Y) = 4$
$corr(X,Y)$	correlation	correlation of random variables X and Y	$corr(X,Y) = 3$
$\rho_{x,y}$	correlation	correlation of random variables X and Y	$\rho_{x,y} = 3$
\sum	summation	summation - sum of all values in range of series	$\sum_{i=1}^4 x_i = x_1 + x_2 + x_3 + x_4$
$\sum\sum$	double summation	double summation	$\sum_{j=1}^2 \sum_{i=1}^8 x_{i,j} = \sum_{i=1}^8 x_{i,1} + \sum_{i=1}^8 x_{i,2}$
Mo	mode	value that occurs most frequently in population	
MR	mid-range	$MR = (x_{max} + x_{min}) / 2$	
Md	sample median	half the population is below this value	
Q_1	lower / first quartile	25% of population are below this value	
Q_2	median / second quartile	50% of population are below this value = median of samples	
Q_3	upper / third quartile	75% of population are below this value	
\bar{x}	sample mean	average / arithmetic mean	$\bar{x} = (2+5+9) / 3 = 5.333$
s^2	sample variance	population samples variance estimator	$s^2 = 4$
s	sample standard deviation	population samples standard deviation estimator	$s = 2$
z_x	standard score	$z_x = (x - \bar{x}) / s_x$	
$X \sim$	distribution of X	distribution of random variable X	$X \sim N(0,3)$
$N(\mu, \sigma^2)$	normal distribution	gaussian distribution	$X \sim N(0,3)$
$U(a,b)$	uniform distribution	equal probability in range a,b	$X \sim U(0,3)$
$exp(\lambda)$	exponential distribution	$f(x) = \lambda e^{-\lambda x}, x \geq 0$	
$gamma(c, \lambda)$	gamma distribution	$f(x) = \lambda c x^{c-1} e^{-\lambda x} / \Gamma(c), x \geq 0$	
$\chi^2(k)$	chi-square distribution	$f(x) = x^{k/2-1} e^{-x/2} / (2^{k/2} \Gamma(k/2))$	
$F(k_1, k_2)$	F distribution		
$Bin(n,p)$	binomial distribution	$f(k) = {}_n C_k p^k (1-p)^{n-k}$	
$Poisson(\lambda)$	Poisson distribution	$f(k) = \lambda^k e^{-\lambda} / k!$	
$Geom(p)$	geometric distribution	$f(k) = p (1-p)^k$	
$HG(N,K,n)$	hyper-geometric distribution		
$Bern(p)$	Bernoulli distribution		

2.6 COMBINATORICS SYMBOLS

Symbol	Symbol Name	Meaning / definition	Example
$n!$	factorial	$n! = 1 \cdot 2 \cdot 3 \cdot \dots \cdot n$	$5! = 1 \cdot 2 \cdot 3 \cdot 4 \cdot 5 = 120$
${}_n P_k$	permutation	${}_n P_k = \frac{n!}{(n-k)!}$	${}_5 P_3 = 5! / (5-3)! = 60$
${}_n C_k$ $\binom{n}{k}$	combination	${}_n C_k = \binom{n}{k} = \frac{n!}{k!(n-k)!}$	${}_5 C_3 = 5! / [3!(5-3)!] = 10$

2.7 SET THEORY SYMBOLS

Symbol	Symbol Name	Meaning / definition	Example
{ }	set	a collection of elements	$A = \{3, 7, 9, 14\}$, $B = \{9, 14, 28\}$
$A \cap B$	intersection	objects that belong to set A and set B	$A \cap B = \{9, 14\}$
$A \cup B$	union	objects that belong to set A or set B	$A \cup B = \{3, 7, 9, 14, 28\}$
$A \subseteq B$	subset	subset has less elements or equal to the set	$\{9, 14, 28\} \subseteq \{9, 14, 28\}$
$A \subset B$	proper subset / strict subset	subset has less elements than the set	$\{9, 14\} \subset \{9, 14, 28\}$
$A \not\subset B$	not subset	left set not a subset of right set	$\{9, 66\} \not\subset \{9, 14, 28\}$
$A \supseteq B$	superset	set A has more elements or equal to the set B	$\{9, 14, 28\} \supseteq \{9, 14, 28\}$
$A \supset B$	proper superset / strict superset	set A has more elements than set B	$\{9, 14, 28\} \supset \{9, 14\}$
$A \not\supset B$	not superset	set A is not a superset of set B	$\{9, 14, 28\} \not\supset \{9, 66\}$
2^A	power set	all subsets of A	
$\mathcal{P}(A)$	power set	all subsets of A	
$A = B$	equality	both sets have the same members	$A = \{3, 9, 14\}$, $B = \{3, 9, 14\}$, $A = B$
A^c	complement	all the objects that do not belong to set A	
$A \setminus B$	relative complement	objects that belong to A and not to B	$A = \{3, 9, 14\}$, $B = \{1, 2, 3\}$, $A \setminus B = \{9, 14\}$
$A - B$	relative complement	objects that belong to A and not to B	$A = \{3, 9, 14\}$, $B = \{1, 2, 3\}$, $A - B = \{9, 14\}$
$A \Delta B$	symmetric difference	objects that belong to A or B but not to their intersection	$A = \{3, 9, 14\}$, $B = \{1, 2, 3\}$, $A \Delta B = \{1, 2, 9, 14\}$
$A \ominus B$	symmetric difference	objects that belong to A or B but not to their intersection	$A = \{3, 9, 14\}$, $B = \{1, 2, 3\}$, $A \ominus B = \{1, 2, 9, 14\}$
$a \in A$	element of	set membership	$A = \{3, 9, 14\}$, $3 \in A$
$x \notin A$	not element of	no set membership	$A = \{3, 9, 14\}$, $1 \notin A$
(a, b)	ordered pair	collection of 2 elements	
$A \times B$	cartesian product	set of all ordered pairs from A and B	
$ A $	cardinality	the number of elements of set A	$A = \{3, 9, 14\}$, $ A = 3$
$\#A$	cardinality	the number of elements of set A	$A = \{3, 9, 14\}$, $\#A = 3$

\aleph	aleph	infinite cardinality	
\emptyset	empty set	$\emptyset = \{ \}$	$C = \{\emptyset\}$
U	universal set	set of all possible values	
\mathbb{N}_0	natural numbers set (with zero)	$\mathbb{N}_0 = \{0,1,2,3,4,\dots\}$	$0 \in \mathbb{N}_0$
\mathbb{N}_1	natural numbers set (without zero)	$\mathbb{N}_1 = \{1,2,3,4,5,\dots\}$	$6 \in \mathbb{N}_1$
\mathbb{Z}	integer numbers set	$\mathbb{Z} = \{\dots-3,-2,-1,0,1,2,3,\dots\}$	$-6 \in \mathbb{Z}$
\mathbb{Q}	rational numbers set	$\mathbb{Q} = \{x \mid x=a/b, a,b \in \mathbb{N}\}$	$2/6 \in \mathbb{Q}$
\mathbb{R}	real numbers set	$\mathbb{R} = \{x \mid -\infty < x < \infty\}$	$6.343434 \in \mathbb{R}$
\mathbb{C}	complex numbers set	$\mathbb{C} = \{z \mid z=a+bi, -\infty < a < \infty, -\infty < b < \infty\}$	$6+2i \in \mathbb{C}$

2.8 LOGIC SYMBOLS

Symbol	Symbol Name	Meaning / definition	Example
\cdot	and	and	$x \cdot y$
\wedge	caret / circumflex	and	$x \wedge y$
$\&$	ampersand	and	$x \& y$
$+$	plus	or	$x + y$
\vee	reversed caret	or	$x \vee y$
$ $	vertical line	or	$x y$
x'	single quote	not - negation	x'
\bar{x}	bar	not - negation	\bar{x}
\neg	not	not - negation	$\neg x$
$!$	exclamation mark	not - negation	$!x$
\oplus	circled plus / oplus	exclusive or - xor	$x \oplus y$
\sim	tilde	negation	$\sim x$
\Rightarrow	implies		
\Leftrightarrow	equivalent	if and only if	
\forall	for all		
\exists	there exists		
\nexists	there does not exist		
\therefore	therefore		
\because	because / since		

2.9 CALCULUS & ANALYSIS SYMBOLS

Symbol	Symbol Name	Meaning / definition	Example
$\lim_{x \rightarrow x_0} f(x)$	limit	limit value of a function	
ε	epsilon	represents a very small number, near zero	$\varepsilon \rightarrow 0$
e	e constant / Euler's number	$e = 2.718281828\dots$	$e = \lim (1+1/x)^x, x \rightarrow \infty$
y'	derivative	derivative - Leibniz's notation	$(3x^3)' = 9x^2$
y''	second derivative	derivative of derivative	$(3x^3)'' = 18x$
$y^{(n)}$	nth derivative	n times derivation	$(3x^3)^{(3)} = 18$
$\frac{dy}{dx}$	derivative	derivative - Lagrange's notation	$d(3x^3)/dx = 9x^2$
$\frac{d^2y}{dx^2}$	second derivative	derivative of derivative	$d^2(3x^3)/dx^2 = 18x$
$\frac{d^ny}{dx^n}$	nth derivative	n times derivation	
\dot{y}	time derivative	derivative by time - Newton notation	
\ddot{y}	time second derivative	derivative of derivative	
$\frac{\partial f(x,y)}{\partial x}$	partial derivative		$\partial(x^2+y^2)/\partial x = 2x$
\int	integral	opposite to derivation	
\iint	double integral	integration of function of 2 variables	
\iiint	triple integral	integration of function of 3 variables	
\oint	closed contour / line integral		
\oiint	closed surface integral		
\oiint	closed volume integral		
$[a,b]$	closed interval	$[a,b] = \{x \mid a \leq x \leq b\}$	
(a,b)	open interval	$(a,b) = \{x \mid a < x < b\}$	
i	imaginary unit	$i \equiv \sqrt{-1}$	$z = 3 + 2i$
z^*	complex conjugate	$z = a+bi \rightarrow z^* = a-bi$	$z^* = 3 - 2i$
\bar{z}	complex conjugate	$z = a+bi \rightarrow \bar{z} = a-bi$	$\bar{z} = 3 - 2i$
∇	nabla / del	gradient / divergence operator	$\nabla f(x,y,z)$
\vec{x}	vector		
\hat{x}	unit vector		
$x * y$	convolution	$y(t) = x(t) * h(t)$	
\mathcal{L}	Laplace transform	$F(s) = \mathcal{L}\{f(t)\}$	
\mathcal{F}	Fourier transform	$X(\omega) = \mathcal{F}\{f(t)\}$	
δ	delta function		

PART 3: AREA, VOLUME AND SURFACE AREA

3.1 AREA

Triangle: $A = \frac{1}{2}bh = \frac{1}{2}ab \sin C = \frac{a^2 \sin B \sin C}{2 \sin A} = \sqrt{s(s-a)(s-b)(s-c)}$

Rectangle: $A = lw$

Square: $A = a^2$

Parallelogram: $A = bh = ab \sin A$

Rhombus: $A = a^2 \sin A$

Trapezium: $A = h \left(\frac{a+b}{s} \right)$

Quadrilateral: $A = \sqrt{(s-a)(s-b)(s-c)(s-d) - abcd \times \cos^2 \left(\frac{\angle AB + \angle CD}{2} \right)}$

$$A = \frac{d_1 d_2 \sin I}{2}$$

Rectangle with rounded corners: $A = lw - r^2(4 - \pi)$

Regular Hexagon: $A = \frac{3\sqrt{3} \times a^2}{2}$

Regular Octagon: $A = 2(1 + \sqrt{2}) \times a^2$

Regular Polygon: $A = \frac{na^2}{4 \tan \left(\frac{180}{n} \right)}$

3.2 VOLUME

Cube: $V = a^3$

Cuboid: $V = abc$

Pyramid: $V = \frac{1}{3} \times A(b) \times h$

Tetrahedron: $V = \frac{\sqrt{2}}{12} \times a^3$

Octahedron: $V = \frac{\sqrt{2}}{3} \times a^3$

Dodecahedron: $V = \frac{15 + 7\sqrt{5}}{4} \times a^3$

Icosahedron: $V = \frac{5(3 + \sqrt{5})}{12} \times a^3$

3.3 SURFACE AREA:

Cube: $SA = 6a^2$

Cuboids: $SA = 2(ab + bc + ca)$

Tetrahedron: $SA = \sqrt{3} \times a^2$

Octahedron:	$SA = 2 \times \sqrt{3} \times a^2$
Dodecahedron:	$SA = 3 \times \sqrt{25 + 10\sqrt{5}} \times a^2$
Icosahedron:	$SA = 5 \times \sqrt{3} \times a^2$
Cylinder:	$SA = 2\pi r(h + r)$

3.4 MISCELLANEOUS

Diagonal of a Rectangle	$d = \sqrt{l^2 + w^2}$
Diagonal of a Cuboid	$d = \sqrt{a^2 + b^2 + c^2}$
Longest Diagonal (Even Sides)	$= \frac{a}{\sin\left(\frac{180}{n}\right)}$
Longest Diagonal (Odd Sides)	$= \frac{a}{2 \sin\left(\frac{90}{n}\right)}$
Total Length of Edges (Cube):	$= 12a$
Total Length of Edges (Cuboid):	$= 4(a + b + c)$

Circumference	$C = 2\pi r = \pi d$
Perimeter of rectangle	$P = 2(a + b)$
Semi perimeter	$s = \frac{P}{2}$
Euler's Formula	$Faces + Vertices = Edges + 2$

3.5 ABBREVIATIONS (3.1, 3.2, 3.3, 3.4)

A=area
 a=side 'a'
 b=base
 b=side 'b'
 C=circumference
 C=central angle
 c=side 'c'
 d=diameter
 d=diagonal
 d₁=diagonal 1
 d₂=diagonal 2
 E=external angle
 h=height
 I=internal angle
 l=length
 n=number of sides
 P=perimeter
 r=radius
 r₁=radius 1

s=semi-perimeter

SA=Surface Area

V=Volume

w=width

PART 4: ALGEBRA

4.1 POLYNOMIAL FORMULA:

Quadratic: Where $ax^2 + bx + c = 0$,

$$x = \frac{-b \pm \sqrt{b^2 - 4ac}}{2a}$$

Cubic: Where $ax^3 + bx^2 + cx + d = 0$,

$$\text{Let, } x = y - \frac{b}{3a}$$

$$\therefore a\left(y - \frac{b}{3a}\right)^3 + b\left(y - \frac{b}{3a}\right)^2 + c\left(y - \frac{b}{3a}\right) + d = 0$$

$$ay^3 + \left(c - \frac{b^2}{3a}\right)y + \left(d + \frac{2b^3}{27a^2} - \frac{bc}{3a}\right) = 0$$

$$y^3 + \frac{\left(c - \frac{b^2}{3a}\right)}{a}y + \frac{\left(d + \frac{2b^3}{27a^2} - \frac{bc}{3a}\right)}{a} = 0$$

$$y^3 + \frac{\left(c - \frac{b^2}{3a}\right)}{a}y = -\frac{\left(d + \frac{2b^3}{27a^2} - \frac{bc}{3a}\right)}{a}$$

$$\text{Let, } A = \frac{\left(c - \frac{b^2}{3a}\right)}{a} = 3st \dots (1)$$

$$\text{Let, } B = -\frac{\left(d + \frac{2b^3}{27a^2} - \frac{bc}{3a}\right)}{a} = s^3 - t^3 \dots (2)$$

$$\therefore y^3 + Ay = B$$

$$y^3 + 3sty = s^3 - t^3$$

Solution to the equation = $s - t$

$$\text{Let, } y = s - t$$

$$\therefore (s - t)^3 + 3st(s - t) = s^3 - t^3$$

$$(s^3 - 3s^2t + 3st^2 - t^3) + (3s^2t - 3st^2) = s^3 - t^3$$

Solving (1) for s and substituting into (2) yields:

$$\left(\frac{A}{3t}\right)^3 - t^3 = B.$$

$$t^6 + Bt^3 - \frac{A^3}{27} = 0,$$

$$\text{Let, } u = t^3$$

$$\therefore u^2 + Bu - \frac{A^3}{27} = 0$$

$$ie: \alpha u^2 + \beta u + \gamma = 0$$

$$\alpha = 1$$

$$\beta = B$$

$$\gamma = -\frac{A^3}{27}$$

$$u = \frac{-\beta \pm \sqrt{\beta^2 - 4\alpha\gamma}}{2\alpha}$$

$$u = \frac{-B \pm \sqrt{B^2 + \frac{4A^3}{27}}}{2}$$

$$\therefore t = \sqrt[3]{u} = \sqrt[3]{\frac{-B \pm \sqrt{B^2 + \frac{4A^3}{27}}}{2}}$$

Substituting into (2) yields:

$$s^3 = B + t^3 = B + \left(\sqrt[3]{\frac{-B \pm \sqrt{B^2 + \frac{4A^3}{27}}}{2}} \right)^3$$

$$\therefore s = \sqrt[3]{B + \left(\sqrt[3]{\frac{-B \pm \sqrt{B^2 + \frac{4A^3}{27}}}{2}} \right)^3}$$

Now, $y = s - t$

$$\therefore y = \sqrt[3]{B + \left(\sqrt[3]{\frac{-B \pm \sqrt{B^2 + \frac{4A^3}{27}}}{2}} \right)^3} - \sqrt[3]{\frac{-B \pm \sqrt{B^2 + \frac{4A^3}{27}}}{2}}$$

Now, $x = y - \frac{b}{3a}$

$$x = \left(\sqrt[3]{B + \left(\sqrt[3]{\frac{-B \pm \sqrt{B^2 + \frac{4A^3}{27}}}{2}} \right)^3} - \sqrt[3]{\frac{-B \pm \sqrt{B^2 + \frac{4A^3}{27}}}{2}} \right) - \frac{b}{3a}$$

$$\text{Where, } A = \frac{\left(c - \frac{b^2}{3a} \right)}{a} \text{ \& } B = -\frac{\left(d + \frac{2b^3}{27a^2} - \frac{bc}{3a} \right)}{a}$$

4.2 ALGEBRAIC EXPANSION:

Babylonian Identity:

$$\left(\frac{1}{2}\left(x - \frac{1}{x}\right)\right)^2 + 1 = \left(\frac{1}{2}\left(x + \frac{1}{x}\right)\right)^2, \quad (\text{c1800BC})$$

Common Products And Factors:

$$(a + b)^2 = a^2 + 2ab + b^2$$

$$(a - b)^2 = a^2 - 2ab + b^2$$

$$(a + b)^3 = a^3 + 3a^2b + 3ab^2 + b^3$$

$$(a - b)^3 = a^3 - 3a^2b + 3ab^2 - b^3$$

$$a^2 - b^2 = (a - b)(a + b)$$

$$a^3 - b^3 = (a - b)(a^2 + ab + b^2)$$

$$a^3 + b^3 = (a + b)(a^2 - ab + b^2)$$

$$(x \pm y)^2 = x^2 \pm 2xy + y^2$$

$$(x \pm y)^3 = x^3 \pm 3x^2y + 3xy^2 \pm y^3$$

$$(x \pm y)^4 = x^4 \pm 4x^3y + 6x^2y^2 \pm 4xy^3 + y^4$$

Binomial Theorem:

For any value of n, whether positive, negative, integer or non-integer, the value of the nth power of a binomial is given by:

$$(a + b)^n = a^n + na^{n-1}b + \frac{n(n-1)}{2}a^{n-2}b^2 + \dots + b^n$$

Binomial Expansion:

For any power of n, the binomial (a + x) can be expanded

$$(a + x)^n = a^n + na^{n-1}x + \frac{n(n-1)}{2}a^{n-2}x^2 + \dots + x^n$$

This is particularly useful when x is very much less than a so that the first few terms provide a good approximation of the value of the expression. There will always be $n+1$ terms and the general form is:

$$(a+x)^n = \sum_{k=0}^n \frac{n!}{(n-k)!k!} a^{n-k} x^k$$

Note that the factorial is given by
 $n! = 1 \cdot 2 \cdot 3 \dots \cdot n$
 $0! = 1$

Difference of two squares:

$$a^2 - b^2 = (a+b)(a-b)$$

Brahmagupta–Fibonacci Identity:

$$(a^2 + b^2)(c^2 + d^2) = (ac - bd)^2 + (ad + bc)^2 \quad (1)$$

$$= (ac + bd)^2 + (ad - bc)^2. \quad (2)$$

Also,

$$(a^2 + nb^2)(c^2 + nd^2) = (ac - nbd)^2 + n(ad + bc)^2 \quad (3)$$

$$= (ac + nbd)^2 + n(ad - bc)^2, \quad (4)$$

Degen's eight-square identity:

$$\begin{aligned} &(a_1^2 + a_2^2 + a_3^2 + a_4^2 + a_5^2 + a_6^2 + a_7^2 + a_8^2)(b_1^2 + b_2^2 + b_3^2 + b_4^2 + b_5^2 + b_6^2 + b_7^2 + b_8^2) = \\ &(a_1b_1 - a_2b_2 - a_3b_3 - a_4b_4 - a_5b_5 - a_6b_6 - a_7b_7 - a_8b_8)^2 + \\ &(a_1b_2 + a_2b_1 + a_3b_4 - a_4b_3 + a_5b_6 - a_6b_5 - a_7b_8 + a_8b_7)^2 + \\ &(a_1b_3 - a_2b_4 + a_3b_1 + a_4b_2 + a_5b_7 + a_6b_8 - a_7b_5 - a_8b_6)^2 + \\ &(a_1b_4 + a_2b_3 - a_3b_2 + a_4b_1 + a_5b_8 - a_6b_7 + a_7b_6 - a_8b_5)^2 + \\ &(a_1b_5 - a_2b_6 - a_3b_7 - a_4b_8 + a_5b_1 + a_6b_2 + a_7b_3 + a_8b_4)^2 + \\ &(a_1b_6 + a_2b_5 - a_3b_8 + a_4b_7 - a_5b_2 + a_6b_1 - a_7b_4 + a_8b_3)^2 + \\ &(a_1b_7 + a_2b_8 + a_3b_5 - a_4b_6 - a_5b_3 + a_6b_4 + a_7b_1 - a_8b_2)^2 + \\ &(a_1b_8 - a_2b_7 + a_3b_6 + a_4b_5 - a_5b_4 - a_6b_3 + a_7b_2 + a_8b_1)^2 \end{aligned}$$

Note that:

$$\begin{aligned} &(a_1^2 + a_2^2 + a_3^2 + a_4^2)(b_1^2 + b_2^2 + b_3^2 + b_4^2) = \\ &(a_1b_1 - a_2b_2 - a_3b_3 - a_4b_4)^2 + \\ &(a_1b_2 + a_2b_1 + a_3b_4 - a_4b_3)^2 + \\ &(a_1b_3 - a_2b_4 + a_3b_1 + a_4b_2)^2 + \\ &(a_1b_4 + a_2b_3 - a_3b_2 + a_4b_1)^2 \end{aligned}$$

and,

$$\begin{aligned} &(a_5^2 + a_6^2 + a_7^2 + a_8^2)(b_1^2 + b_2^2 + b_3^2 + b_4^2) = \\ &(a_5b_1 + a_6b_2 + a_7b_3 + a_8b_4)^2 + \end{aligned}$$

$$\begin{aligned} & (a_5b_2 - a_6b_1 + a_7b_4 - a_8b_3)^2 + \\ & (a_5b_3 - a_6b_4 - a_7b_1 + a_8b_2)^2 + \\ & (a_5b_4 + a_6b_3 - a_7b_2 - a_8b_1)^2 \end{aligned}$$

4.3 LIMIT MANIPULATIONS:

$$\begin{aligned} \lim_{n \rightarrow \infty} (a_n \pm b_n) &= \left(\lim_{n \rightarrow \infty} (a_n) \right) \pm \left(\lim_{n \rightarrow \infty} (b_n) \right) \\ \lim_{n \rightarrow \infty} (ka_n) &= k \left(\lim_{n \rightarrow \infty} (a_n) \right) \\ \lim_{n \rightarrow \infty} (a_n b_n) &= \left(\lim_{n \rightarrow \infty} (a_n) \right) \left(\lim_{n \rightarrow \infty} (b_n) \right) \\ \lim_{n \rightarrow \infty} (f(a_n)) &= f \left(\lim_{n \rightarrow \infty} (a_n) \right) \end{aligned}$$

4.4 SUMATION MANIPULATIONS:

$$\begin{aligned} \sum_{n=s}^t C \cdot f(n) &= C \cdot \sum_{n=s}^t f(n), \text{ where } C \text{ is a constant} \\ \sum_{n=s}^t f(n) + \sum_{n=s}^t g(n) &= \sum_{n=s}^t [f(n) + g(n)] \\ \sum_{n=s}^t f(n) - \sum_{n=s}^t g(n) &= \sum_{n=s}^t [f(n) - g(n)] \\ \sum_{n=s}^t f(n) &= \sum_{n=s+p}^t f(n-p) \\ \sum_{n=s}^j f(n) + \sum_{n=j+1}^t f(n) &= \sum_{n=s}^t f(n) \\ \left(\sum_{i=k_0}^{k_1} a_i \right) \left(\sum_{j=l_0}^{l_1} b_j \right) &= \sum_{i=k_0}^{k_1} \sum_{j=l_0}^{l_1} a_i b_j \\ \sum_{i=k_0}^{k_1} \sum_{j=l_0}^{l_1} a_{i,j} &= \sum_{j=l_0}^{l_1} \sum_{i=k_0}^{k_1} a_{i,j} \\ \sum_{n=0}^t f(2n) + \sum_{n=0}^{t-1} f(2n+1) &= \sum_{n=0}^{2t+1} f(n) \\ \sum_{n=0}^t \sum_{i=0}^{z \cdot n + i} f(z \cdot n + i) &= \sum_{n=0}^t f(n) \\ \sum_{n=s}^t \ln f(n) &= \ln \prod_{n=s}^t f(n) \\ c^{\left[\sum_{n=s}^t f(n) \right]} &= \prod_{n=s}^t c^{f(n)} \end{aligned}$$

4.5 COMMON FUNCTIONS:

Constant Function:

$$y=a \text{ or } f(x)=a$$

Graph is a horizontal line passing through the point $(0,a)$
 $x=a$

Graph is a vertical line passing through the point $(a,0)$

Line/Linear Function:

$$y = mx + c$$

Graph is a line with point $(0,c)$ and slope m .

Where the gradient is between any two points (x_1, y_1) & (x_2, y_2)

$$m = \frac{\text{rise}}{\text{run}} = \frac{y_2 - y_1}{x_2 - x_1}$$

Also, $y = y_1 + m(x - x_1)$

The equation of the line with gradient m and passing through the point (x_1, y_1) .

Parabola/Quadratic Function:

$$y = a(x - h)^2 + k$$

The graph is a parabola that opens up if $a > 0$ or down if $a < 0$ and has a vertex at (h,k) .

$$y = ax^2 + bx + c$$

The graph is a parabola that opens up if $a > 0$ or down if $a < 0$ and has a vertex at $\left(\frac{-b}{2a}, f\left(\frac{-b}{2a}\right)\right)$.

$$x = ay^2 + by + c$$

The graph is a parabola that opens right if $a > 0$ or left if $a < 0$ and has a vertex at $\left(g\left(\frac{-b}{2a}\right), \left(\frac{-b}{2a}\right)\right)$. This is not a function.

Circle:

$$(x - h)^2 + (y - k)^2 = r^2$$

Graph is a circle with radius r and center (h,k) .

Ellipse:

$$\frac{(x - h)^2}{a^2} + \frac{(y - k)^2}{b^2} = 1$$

Graph is an ellipse with center (h,k) with vertices a units right/left from the center and vertices b units up/down from the center.

Hyperbola:

$$\frac{(x-h)^2}{a^2} - \frac{(y-k)^2}{b^2} = 1$$

Graph is a hyperbola that opens left and right, has a center at (h,k) , vertices a units left/right of center and asymptotes that pass through center with slope $\pm \frac{b}{a}$.

$$\frac{(y-k)^2}{b^2} - \frac{(x-h)^2}{a^2} = 1$$

Graph is a hyperbola that opens up and down, has a center at (h,k) , vertices b units up/down from the center and asymptotes that pass through center with slope $\pm \frac{b}{a}$.

4.6 LINEAR ALGEBRA:

Vector Space Axioms:

Let V be a set on which addition and scalar multiplication are defined (this means that if u and v are objects in V and c is a scalar then we've defined $\mathbf{u} + \mathbf{v}$ and $c\mathbf{u}$ in some way). If the following axioms are true for all objects u, v , and w in V and all scalars c and k then V is called a vector space and the objects in V are called vectors.

(a) $\mathbf{u} + \mathbf{v}$ is in V — This is called closed under addition.

(b) $c\mathbf{u}$ is in V — This is called closed under scalar multiplication.

(c) $\mathbf{u} + \mathbf{v} = \mathbf{v} + \mathbf{u}$ $\mathbf{u} + \mathbf{v} = \mathbf{v} + \mathbf{u}$

(d) $\mathbf{u} + (\mathbf{v} + \mathbf{w}) = (\mathbf{u} + \mathbf{v}) + \mathbf{w}$

$\mathbf{u} + (\mathbf{v} + \mathbf{w}) = (\mathbf{u} + \mathbf{v}) + \mathbf{w}$

(e) There is a special object in V , denoted $\mathbf{0}$ and called the zero vector, such that for all u in V we have $\mathbf{u} + \mathbf{0} = \mathbf{0} + \mathbf{u} = \mathbf{u}$ $\mathbf{u} + \mathbf{0} = \mathbf{0} + \mathbf{u} = \mathbf{u}$.

(f) For every u in V there is another object in V , denoted $-\mathbf{u}$ and called the negative of u , such that $\mathbf{u} - \mathbf{u} = \mathbf{u} + (-\mathbf{u}) = \mathbf{0}$

$\mathbf{u} - \mathbf{u} = \mathbf{u} + (-\mathbf{u}) = \mathbf{0}$.

(g) $c(\mathbf{u} + \mathbf{v}) = c\mathbf{u} + c\mathbf{v}$ $c(\mathbf{u} + \mathbf{v}) = c\mathbf{u} + c\mathbf{v}$

(h) $(c + k)\mathbf{u} = c\mathbf{u} + k\mathbf{u}$ $(c + k)\mathbf{u} = c\mathbf{u} + k\mathbf{u}$

(i) $c(k\mathbf{u}) = (ck)\mathbf{u}$ $c(k\mathbf{u}) = (ck)\mathbf{u}$

(j) $1\mathbf{u} = \mathbf{u}$ $1\mathbf{u} = \mathbf{u}$

Subspace: When the subspace is a subset of another vector space, only axioms (a) and (b) need to be proved to show that the subspace is also a vector space.

Common Spaces:

Real Numbers	$\mathcal{R}, \mathcal{R}^2, \mathcal{R}^3, \dots, \mathcal{R}^n$ (n denotes dimension)
Complex Numbers:	C, C^2, C^3, \dots, C^n (n denotes dimension)
Polynomials	$P_1, P_2, P_3, \dots, P_n$ (n denotes the highest order of x)
All continuous functions	$C[a, b]$ (a & b denote the interval) (This is never a vector space as it has infinite dimensions)

Rowspace of a spanning set in \mathbf{R}^n

Stack vectors in a matrix in rows

Use elementary row operations to put matrix into row echelon form

The non zero rows form a basis of the vector space

Columnspace of a spanning set in \mathbf{R}^n

Stack vectors in a matrix in columns

Use elementary row operations to put matrix into row echelon form

Columns with leading entries correspond to the subset of vectors in the set that form a basis

Nullspace:

Solutions to $Ax = 0$

Using elementary row operations to put matrix into row echelon form, columns with no leading entries are assigned a constant and the remaining variables are solved with respect to these constants.

Nullity:

The dimension of the nullspace

$$\text{Columns}(A) = \text{Nullity}(A) + \text{Rank}(A)$$

Linear Dependence:

$$c_1r_1 + c_2r_2 + \dots + c_nr_n = 0$$

Then, $c_1 = c_2 = \dots = c_n = 0$

If the trivial solution is the only solution, r_1, r_2, \dots, r_n are independent.

$r(A) \neq r(A|b)$: No Solution

$r(A) = r(A|b) = n$: Unique Solution

$r(A) = r(A|b) < n$: Infinite Solutions

Basis: S is a basis of V if:

S spans V

S is linearly independent

$$S = \{u_1, u_2, u_3, \dots, u_n\}$$

The general vector within the vector space is: $w = \begin{bmatrix} x \\ y \\ z \\ \dots \end{bmatrix}$

$$w = c_1u_1 + c_2u_2 + c_3u_3 + \dots + c_nu_n$$

Therefore,
$$[w] = \begin{bmatrix} u_{11} & u_{21} & u_{31} & \dots & u_{n1} \\ u_{12} & u_{22} & u_{32} & \dots & u_{n2} \\ u_{13} & u_{23} & u_{33} & \dots & u_{n3} \\ \dots & \dots & \dots & \dots & \dots \\ u_{1n} & u_{2n} & u_{3n} & \dots & u_{nn} \end{bmatrix} \begin{bmatrix} c_1 \\ c_2 \\ c_3 \\ \dots \\ c_n \end{bmatrix}$$

If the determinant of the square matrix is not zero, the matrix is invertible. Therefore, the solution is unique. Hence, all vectors in w are linear combinations of S . Because of this, S spans w .

Standard Basis:

Real Numbers
$$S(\mathfrak{R}^n) = \left\{ \begin{bmatrix} 1 \\ 0 \\ 0 \\ \dots \\ 0 \end{bmatrix}, \begin{bmatrix} 0 \\ 1 \\ 0 \\ \dots \\ 0 \end{bmatrix}, \begin{bmatrix} 0 \\ 0 \\ 1 \\ \dots \\ 0 \end{bmatrix}, \dots, \begin{bmatrix} 0 \\ 0 \\ 0 \\ \dots \\ 1 \end{bmatrix} \right\}$$

Polynomials
$$S(P_n) = \{1, x, x^2, x^3, \dots, x^n\}$$

Any set that forms the basis of a vector space must contain the same number of linearly independent vectors as the standard basis.

Orthogonal Complement:

W^\perp is the nullspace of A , where A is the matrix that contains $\{v_1, v_2, v_3, \dots, v_n\}$ in rows.

$$\dim(W^\perp) = \text{nullity}(A)$$

Orthonormal Basis:

A basis of mutually orthogonal vectors of length 1. Basis can be found with the Gram-Schmidt process outlined below.

$$\langle v_i, v_j \rangle = \begin{cases} 0 & i \neq j \\ 1 & i = j \end{cases}$$

In an orthonormal basis:

$$u = \langle u, v_1 \rangle v_1 + \langle u, v_2 \rangle v_2 + \langle u, v_3 \rangle v_3 + \dots + \langle u, v_n \rangle v_n$$

$$u = c_1v_1 + c_2v_2 + c_3v_3 + \dots + c_nv_n$$

Gram-Schmidt Process:

This finds an orthonormal basis recursively.

In a basis $B = \{u_1, u_2, u_3, \dots, u_n\}$

$$q_1 = u_1$$

$$v_1 = \hat{q}_1 = \frac{q_1}{\|q_1\|}$$

Next vector needs to be orthogonal to v_1 ,

$$q_2 = u_2 - \langle u_2, v_1 \rangle v_1$$

Similarly

$$q_3 = u_3 - \langle u_3, v_1 \rangle v_1 - \langle u_3, v_2 \rangle v_2$$

$$q_n = u_n - \langle u_n, v_1 \rangle v_1 - \langle u_n, v_2 \rangle v_2 - \dots - \langle u_n, v_{n-1} \rangle v_{n-1}$$

$$v_n = \hat{q}_n = \frac{q_n}{\|q_n\|}$$

Coordinate Vector:

If $v = c_1 e_1 + c_2 e_2 + \dots + c_n e_n$

$$v_B = \begin{bmatrix} c_1 \\ c_2 \\ \dots \\ c_n \end{bmatrix}$$

For a fixed basis (usually the standard basis) there is 1 to 1 correspondence between vectors and coordinate vectors.

Hence, a basis can be found in \mathbb{R}^n and then translated back into the general vector space.

Dimension:

Real Numbers $\dim(\mathfrak{R}^n) = n$

Polynomials $\dim(P_n) = n + 1$

Matricis $\dim(M_{p,q}) = p \times q$

If you know the dimensions and you are checking if a set forms a basis of the vector space, only Linear Independence or Span needs to be checked.

4.7 COMPLEX VECTOR SPACES:

Form: $C^n = \begin{bmatrix} a_1 + ib_1 \\ a_2 + ib_2 \\ \dots \\ a_n + ib_n \end{bmatrix}$

Dot Product:

$$u \bullet v = \bar{u}_1 v_1 + \bar{u}_2 v_2 + \dots + \bar{u}_n v_n$$

Where:

$$u \bullet v = \overline{v \bullet u} \neq v \bullet u$$

$$(u + v) \bullet w = u \bullet w + v \bullet w$$

$$su \bullet v = \overline{s}(u \bullet v), s \in \mathbb{C}$$

$$u \bullet u \geq 0$$

$$u \bullet u = 0 \text{ iff } u = 0$$

Inner Product:

$$\|u\| = \sqrt{u \bullet u} = \sqrt{|u_1|^2 + |u_2|^2 + \dots + |u_n|^2}$$

$$d(u, v) = \|u - v\|$$

Orthogonal if $u \bullet v = 0$

Parallel if $u = sv, s \in \mathbb{C}$

4.8 LINEAR TRANSITIONS & TRANSFORMATIONS:

Transition Matrix: From 1 vector space to another vector space

$$T(u) = T(c_1u_1 + c_2u_2 + c_3u_3 + \dots + c_nu_n)$$

$$T(u) = c_1T(u_1) + c_2T(u_2) + c_3T(u_3) + \dots + c_nT(u_n)$$

$$\text{Nullity}(T) + \text{Rank}(T) = \text{Dim}(V) = \text{Columns}(T)$$

Change of Basis Transition Matrix:

$$v_{B'} = M_{B'}^{-1} M_B v_B$$

$$v_{B'} = C_{BB'} v_B$$

For a general vector space with the standard basis: $S = \{s_1, s_2, \dots, s_n\}$

$$M_B = [(v_1)_S \mid \dots \mid (v_n)_S]$$

$$M_{B'} = [(u_1)_S \mid \dots \mid (u_m)_S]$$

Transformation Matrix: From 1 basis to another basis

$$V = \text{span}(\{v_1, v_2, v_3, \dots, v_n\})$$

$$B_1 = \{v_1, v_2, v_3, \dots, v_n\}$$

$$U = \text{span}(\{u_1, u_2, u_3, \dots, u_m\})$$

$$B_2 = \{u_1, u_2, u_3, \dots, u_m\}$$

$$A = [(T(v_1))_{B_2} \mid (T(v_2))_{B_2} \mid \dots \mid (T(v_n))_{B_2}]$$

$$A' = C_{B'B}^{-1} A C_{BB'}$$

4.9 INNER PRODUCTS:

Definition: An extension of the dot product into a general vector space.

Axioms:

1. $\langle u, v \rangle = \langle v, u \rangle$
2. $\langle u, v + w \rangle = \langle u, v \rangle + \langle u, w \rangle$

3. $\langle ku, v \rangle = k \langle u, v \rangle$
4. $\langle u, u \rangle \geq 0$
 $\langle u, u \rangle = 0$ iff $u = 0$

Unit Vector: $\hat{u} = \frac{u}{\|u\|}$

Cavchy-Schwarz Inequality: $\langle u, v \rangle^2 \leq \langle u, u \rangle \times \langle v, v \rangle$

Inner Product Space:

$$\|u\| = \langle u, u \rangle^{\frac{1}{2}} = \sqrt{\langle u, u \rangle}$$

$$\|u\|^2 = \langle u, u \rangle$$

$$\langle u, v \rangle^2 \leq \|u\|^2 \times \|v\|^2 \Rightarrow \left(\frac{\langle u, v \rangle}{\|u\| \|v\|} \right)^2 \leq 1 \Rightarrow -1 \leq \frac{\langle u, v \rangle}{\|u\| \|v\|} \leq 1$$

$$\|u\| \geq 0, \|u\| = 0 \text{ iff } u = 0$$

$$\|ku\| = |k| \|u\|$$

$$\|u + v\| = \|u\| + \|v\|$$

Angle between two vectors:

As defined by the inner product,

$$\cos(\theta) = \frac{\langle u, v \rangle}{\|u\| \|v\|}$$

Orthogonal if: $\langle u, v \rangle = 0$

Distance between two vectors:

As defined by the inner product,

$$d(u, v) = \|u - v\|$$

Generalised Pythagoras for orthogonal vectors:

$$\|u + v\|^2 = \|u\|^2 + \|v\|^2$$

4.10 PRIME NUMBERS:

Determinate:
$$\Delta(N) = \begin{cases} 1 + \left\lfloor \frac{3}{N} \right\rfloor & \text{if } N \text{ is odd and prime} \\ 1 + \sum_{k=1}^{\left\lfloor \frac{\sqrt{N+1}}{2} \right\rfloor} \left\lfloor \frac{2k+1}{N} \times \left\lfloor \frac{N}{2k+1} \right\rfloor \right\rfloor & \text{if } N \text{ is odd and composite} \end{cases}$$

List of Prime Numbers:

2	3	5	7	11	13	17	19	23	29	31	37	41	43	47	53	59	61	67	71
73	79	83	89	97	101	103	107	109	113	127	131	137	139	149	151	157	163	167	173
179	181	191	193	197	199	211	223	227	229	233	239	241	251	257	263	269	271	277	281
283	293	307	311	313	317	331	337	347	349	353	359	367	373	379	383	389	397	401	409
419	421	431	433	439	443	449	457	461	463	467	479	487	491	499	503	509	521	523	541
547	557	563	569	571	577	587	593	599	601	607	613	617	619	631	641	643	647	653	659
661	673	677	683	691	701	709	719	727	733	739	743	751	757	761	769	773	787	797	809

811	821	823	827	829	839	853	857	859	863	877	881	883	887	907	911	919	929	937	941
947	953	967	971	977	983	991	997	1009	1013	1019	1021	1031	1033	1039	1049	1051	1061	1063	1069
1087	1091	1093	1097	1103	1109	1117	1123	1129	1151	1153	1163	1171	1181	1187	1193	1201	1213	1217	1223
1229	1231	1237	1249	1259	1277	1279	1283	1289	1291	1297	1301	1303	1307	1319	1321	1327	1361	1367	1373
1381	1399	1409	1423	1427	1429	1433	1439	1447	1451	1453	1459	1471	1481	1483	1487	1489	1493	1499	1511
1523	1531	1543	1549	1553	1559	1567	1571	1579	1583	1597	1601	1607	1609	1613	1619	1621	1627	1637	1657
1663	1667	1669	1693	1697	1699	1709	1721	1723	1733	1741	1747	1753	1759	1777	1783	1787	1789	1801	1811
1823	1831	1847	1861	1867	1871	1873	1877	1879	1889	1901	1907	1913	1931	1933	1949	1951	1973	1979	1987
1993	1997	1999	2003	2011	2017	2027	2029	2039	2053	2063	2069	2081	2083	2087	2089	2099	2111	2113	2129
2131	2137	2141	2143	2153	2161	2179	2203	2207	2213	2221	2237	2239	2243	2251	2267	2269	2273	2281	2287
2293	2297	2309	2311	2333	2339	2341	2347	2351	2357	2371	2377	2381	2383	2389	2393	2399	2411	2417	2423
2437	2441	2447	2459	2467	2473	2477	2503	2521	2531	2539	2543	2549	2551	2557	2579	2591	2593	2609	2617
2621	2633	2647	2657	2659	2663	2671	2677	2683	2687	2689	2693	2699	2707	2711	2713	2719	2729	2731	2741
2749	2753	2767	2777	2789	2791	2797	2801	2803	2819	2833	2837	2843	2851	2857	2861	2879	2887	2897	2903
2909	2917	2927	2939	2953	2957	2963	2969	2971	2999	3001	3011	3019	3023	3037	3041	3049	3061	3067	3079
3083	3089	3109	3119	3121	3137	3163	3167	3169	3181	3187	3191	3203	3209	3217	3221	3229	3251	3253	3257
3259	3271	3299	3301	3307	3313	3319	3323	3329	3331	3343	3347	3359	3361	3371	3373	3389	3391	3407	3413
3433	3449	3457	3461	3463	3467	3469	3491	3499	3511	3517	3527	3529	3533	3539	3541	3547	3557	3559	3571

Perfect Numbers: A perfect number is a positive integer that is equal to the sum of its proper positive divisors, excluding the number itself. Even perfect numbers are of the form $2^{p-1}(2^p-1)$, where (2^p-1) is prime and by extension p is also prime. It is unknown whether there are any odd perfect numbers.

List of Perfect Numbers:

Rank	p	Perfect number	Digits	Year	Discoverer
1	2	6	1	Known to the Greeks	
2	3	28	2	Known to the Greeks	
3	5	496	3	Known to the Greeks	
4	7	8128	4	Known to the Greeks	
5	13	33550336	8	1456	First seen in the medieval manuscript, Codex Lat. Monac.
6	17	8589869056	10	1588	Cataldi
7	19		12	1588	Cataldi
8	31		19	1772	Euler
9	61		37	1883	Pervushin
10	89		54	1911	Powers
11	107		65	1914	Powers
12	127		77	1876	Lucas
13	521		314	1952	Robinson
14	607		366	1952	Robinson
15	1279		770	1952	Robinson
16	2203		1327	1952	Robinson
17	2281		1373	1952	Robinson
18	3217		1937	1957	Riesel
19	4253		2561	1961	Hurwitz
20	4423		2663	1961	Hurwitz
21	9689		5834	1963	Gillies
22	9941		5985	1963	Gillies
23	11213		6751	1963	Gillies

24	19937		12003	1971	Tuckerman
25	21701		13066	1978	Noll & Nickel
26	23209		13973	1979	Noll
27	44497		26790	1979	Nelson & Slowinski
28	86243		51924	1982	Slowinski
29	110503		66530	1988	Colquitt & Welsh
30	132049		79502	1983	Slowinski
31	216091		130100	1985	Slowinski
32	756839		455663	1992	Slowinski & Gage
33	859433		517430	1994	Slowinski & Gage
34	1257787		757263	1996	Slowinski & Gage
35	1398269		841842	1996	Armengaud, Woltman, et al.
36	2976221		1791864	1997	Spence, Woltman, et al.
37	3021377		1819050	1998	Clarkson, Woltman, Kurowski, et al.
38	6972593		4197919	1999	Hajratwala, Woltman, Kurowski, et al.
39	13466917		8107892	2001	Cameron, Woltman, Kurowski, et al.
40	20996011		12640858	2003	Shafer, Woltman, Kurowski, et al.
41	24036583		14471465	2004	Findley, Woltman, Kurowski, et al.
42	25964951		15632458	2005	Nowak, Woltman, Kurowski, et al.
43	30402457		18304103	2005	Cooper, Boone, Woltman, Kurowski, et al.
44	32582657		19616714	2006	Cooper, Boone, Woltman, Kurowski, et al.
45	37156667		22370543	2008	Elvenich, Woltman, Kurowski, et al.
46	42643801		25674127	2009	Strindmo, Woltman, Kurowski, et al.
47	43112609		25956377	2008	Smith, Woltman, Kurowski, et al.

Amicable Numbers: Amicable numbers are two different numbers so related that the sum of the proper divisors of each is equal to the other number.

List of Amicable Numbers:

Amicable Pairs		Amicable Pairs		Amicable Pairs	
220	284	1,328,470	1,483,850	8,619,765	9,627,915
1,184	1,210	1,358,595	1,486,845	8,666,860	10,638,356
2,620	2,924	1,392,368	1,464,592	8,754,130	10,893,230
5,020	5,564	1,466,150	1,747,930	8,826,070	10,043,690
6,232	6,368	1,468,324	1,749,212	9,071,685	9,498,555
10,744	10,856	1,511,930	1,598,470	9,199,496	9,592,504
12,285	14,595	1,669,910	2,062,570	9,206,925	10,791,795
17,296	18,416	1,798,875	1,870,245	9,339,704	9,892,936
63,020	76,084	2,082,464	2,090,656	9,363,584	9,437,056
66,928	66,992	2,236,570	2,429,030	9,478,910	11,049,730
67,095	71,145	2,652,728	2,941,672	9,491,625	10,950,615
69,615	87,633	2,723,792	2,874,064	9,660,950	10,025,290
79,750	88,730	2,728,726	3,077,354	9,773,505	11,791,935
100,485	124,155	2,739,704	2,928,136	10,254,970	10,273,670
122,265	139,815	2,802,416	2,947,216	10,533,296	10,949,704
122,368	123,152	2,803,580	3,716,164	10,572,550	10,854,650
141,664	153,176	3,276,856	3,721,544	10,596,368	11,199,112
142,310	168,730	3,606,850	3,892,670	10,634,085	14,084,763
171,856	176,336	3,786,904	4,300,136	10,992,735	12,070,305
176,272	180,848	3,805,264	4,006,736	11,173,460	13,212,076

185,368	203,432	4,238,984	4,314,616	11,252,648	12,101,272
196,724	202,444	4,246,130	4,488,910	11,498,355	12,024,045
280,540	365,084	4,259,750	4,445,050	11,545,616	12,247,504
308,620	389,924	4,482,765	5,120,595	11,693,290	12,361,622
319,550	430,402	4,532,710	6,135,962	11,905,504	13,337,336
356,408	399,592	4,604,776	5,162,744	12,397,552	13,136,528
437,456	455,344	5,123,090	5,504,110	12,707,704	14,236,136
469,028	486,178	5,147,032	5,843,048	13,671,735	15,877,065
503,056	514,736	5,232,010	5,799,542	13,813,150	14,310,050
522,405	525,915	5,357,625	5,684,679	13,921,528	13,985,672
600,392	669,688	5,385,310	5,812,130	14,311,688	14,718,712
609,928	686,072	5,459,176	5,495,264	14,426,230	18,087,818
624,184	691,256	5,726,072	6,369,928	14,443,730	15,882,670
635,624	712,216	5,730,615	6,088,905	14,654,150	16,817,050
643,336	652,664	5,864,660	7,489,324	15,002,464	15,334,304
667,964	783,556	6,329,416	6,371,384	15,363,832	16,517,768
726,104	796,696	6,377,175	6,680,025	15,938,055	17,308,665
802,725	863,835	6,955,216	7,418,864	16,137,628	16,150,628
879,712	901,424	6,993,610	7,158,710	16,871,582	19,325,698
898,216	980,984	7,275,532	7,471,508	17,041,010	19,150,222
947,835	1,125,765	7,288,930	8,221,598	17,257,695	17,578,785
998,104	1,043,096	7,489,112	7,674,088	17,754,165	19,985,355
1,077,890	1,099,390	7,577,350	8,493,050	17,844,255	19,895,265
1,154,450	1,189,150	7,677,248	7,684,672	17,908,064	18,017,056
1,156,870	1,292,570	7,800,544	7,916,696	18,056,312	18,166,888
1,175,265	1,438,983	7,850,512	8,052,488	18,194,715	22,240,485
1,185,376	1,286,744	8,262,136	8,369,864	18,655,744	19,154,336
1,280,565	1,340,235				

Sociable Numbers: Sociable numbers are generalisations of amicable numbers where a sequence of numbers each of whose numbers is the sum of the factors of the preceding number, excluding the preceding number itself. The sequence must be cyclic, eventually returning to its starting point

List of Sociable Numbers:

C4s	
1264460	
1547860	
1727636	
1305184	
2115324	
3317740	
3649556	
2797612	
2784580	
3265940	
3707572	

3370604	
4938136	
5753864	
5504056	
5423384	
7169104	
7538660	
8292568	
7520432	
C5 Poulet 1918 5D	
12496	2^4*11*71
14288	2^4*19*47
15472	2^4*967
14536	2^3*23*79
14264	2^3*1783
C6 Moews&Moews 1992 11D	
21548919483	3^5*7^2*13*19*17*431
23625285957	3^5*7^2*13*19*29*277
24825443643	3^2*7^2*13*19*11*20719
26762383557	3^4*7^2*13*19*27299
25958284443	3^2*7^2*13*19*167*1427
23816997477	3^2*7^2*13*19*218651
C6 Moews&Moews 1995 11D/12D	
90632826380	2^2*5*109*431*96461
101889891700	2^2*5^2*31*193*170299
127527369100	2^2*5^2*31*181*227281
159713440756	2^2*31*991*1299709
129092518924	2^2*31*109*9551089
106246338676	2^2*17*25411*61487
C6 Needham 2006 13D	
1771417411016	2^3*11*20129743307
1851936384424	2^3*7*1637*20201767
2118923133656	2^3*7*863*43844627
2426887897384	2^3*59*5141711647
2200652585816	2^3*43*1433*4464233
2024477041144	2^3*253059630143
C6 Needham 2006 13D	
3524434872392	2^3*7*17*719*5149009
4483305479608	2^3*89*6296777359
4017343956392	2^3*13*17*3019*752651
4574630214808	2^3*607*6779*138967
4018261509992	2^3*31*59*274621481
3890837171608	2^3*61*22039*361769

C6 Needham 2006 13D	
4773123705616	2^4*7*347*122816069
5826394399664	2^4*101*3605442079
5574013457296	2^4*53*677*1483*6547
5454772780208	2^4*53*239*2971*9059
5363145542992	2^4*307*353*3093047
5091331952624	2^4*318208247039
C8 Flammenkamp 1990 Brodie ? 10D	
1095447416	2^3*7*313*62497
1259477224	2^3*43*3661271
1156962296	2^3*7*311*66431
1330251784	2^3*43*3867011
1221976136	2^3*41*1399*2663
1127671864	2^3*11*61*83*2531
1245926216	2^3*19*8196883
1213138984	2^3*67*2263319
C8 Flammenkamp 1990 Brodie ? 10D	
1276254780	2^2*3*5*1973*10781
2299401444	2^2*3*991*193357
3071310364	2^2*767827591
2303482780	2^2*5*67*211*8147
2629903076	2^2*23*131*218213
2209210588	2^2*13^2*17*192239
2223459332	2^2*131*4243243
1697298124	2^2*907*467833
C9 Flammenkamp 1990 9D/10D	
805984760	2^3*5*7*1579*1823
1268997640	2^3*5*17*61*30593
1803863720	2^3*5*103*367*1193
2308845400	2^3*5^2*11544227
3059220620	2^2*5*2347*65173
3367978564	2^2*841994641
2525983930	2*5*17*367*40487
2301481286	2*13*19*4658869
1611969514	2*805984757
C28 Poulet 1918 5D/6D	
14316	2^2*3*1193
19116	2^2*3^4*59
31704	2^3*3*1321
47616	2^9*3*31
83328	2^7*3*7*31
177792	2^7*3*463
295488	2^6*3^5*19
629072	2^4*39317
589786	2*294893
294896	2^4*7*2633

358336	$2^6 \cdot 11 \cdot 509$
418904	$2^3 \cdot 52363$
366556	$2^2 \cdot 91639$
274924	$2^2 \cdot 13 \cdot 17 \cdot 311$
275444	$2^2 \cdot 13 \cdot 5297$
243760	$2^4 \cdot 5 \cdot 11 \cdot 277$
376736	$2^5 \cdot 61 \cdot 193$
381028	$2^2 \cdot 95257$
285778	$2 \cdot 43 \cdot 3323$
152990	$2 \cdot 5 \cdot 15299$
122410	$2 \cdot 5 \cdot 12241$
97946	$2 \cdot 48973$
48976	$2^4 \cdot 3061$
45946	$2 \cdot 22973$
22976	$2^6 \cdot 359$
22744	$2^3 \cdot 2843$
19916	$2^2 \cdot 13 \cdot 383$
17716	$2^2 \cdot 43 \cdot 103$
This list is exhaustive for known social numbers where $C > 4$	

4.11 GOLDEN RATIO & FIBONACCI SEQUENCE:

Relationship:

$$\frac{a+b}{a} = \frac{a}{b} \equiv \varphi,$$

$$\frac{a+b}{a} = 1 + \frac{b}{a} = 1 + \frac{1}{\varphi},$$

$$\varphi = \frac{1 + \sqrt{5}}{2} = 1.6180339887\dots$$

$$\varphi^{n+1} = \varphi^n + \varphi^{n-1}.$$

Infinite Series:

$$\varphi = \sqrt{1 + \sqrt{1 + \sqrt{1 + \sqrt{1 + \dots}}}}$$

$$\varphi = \frac{13}{8} + \sum_{n=0}^{\infty} \frac{(-1)^{(n+1)}(2n+1)!}{(n+2)!n!4^{(2n+3)}}.$$

Continued Fractions:

$$\varphi = [1; 1, 1, 1, \dots] = 1 + \frac{1}{1 + \frac{1}{1 + \frac{1}{1 + \dots}}}$$

$$\varphi^{-1} = [0; 1, 1, 1, \dots] = 0 + \frac{1}{1 + \frac{1}{1 + \frac{1}{1 + \dots}}}$$

Trigonometric Expressions:

$$\varphi = 1 + 2 \sin(\pi/10) = 1 + 2 \sin 18^\circ$$

$$\varphi = \frac{1}{2} \csc(\pi/10) = \frac{1}{2} \csc 18^\circ$$

$$\varphi = 2 \cos(\pi/5) = 2 \cos 36^\circ$$

$$\varphi = 2 \sin(3\pi/10) = 2 \sin 54^\circ.$$

Fibonacci Sequence:

$$F(n) = \frac{\varphi^n - (1-\varphi)^n}{\sqrt{5}} = \frac{\varphi^n - (-\varphi)^{-n}}{\sqrt{5}}$$

$$F(n) = \frac{1}{\sqrt{5}} \left(\left(\frac{1+\sqrt{5}}{2} \right)^n - \left(\frac{1-\sqrt{5}}{2} \right)^n \right)$$

$$\lim_{n \rightarrow \infty} \frac{F(n+1)}{F(n)} = \varphi.$$

$$\sum_{n=1}^{\infty} |F(n)\varphi - F(n+1)| = \varphi.$$

$$\lim_{n \rightarrow \infty} \frac{F(n+a)}{F(n)} = \varphi^a,$$

4.12 FERMAT'S LAST THEOREM:

$$a^n + b^n \neq c^n \text{ for integers } a, b \text{ \& } c \text{ and } n > 2$$

Proposed by Fermat in 1637 and proved by Andrew Wiles in 1994. The proof is too long to be written here. See: <http://www.cs.berkeley.edu/~anindya/fermat.pdf>

PART 5: COUNTING TECHNIQUES & PROBABILITY

5.1 2D

Triangle Number $T_n = \frac{n(n+1)}{2}$

$$n^2 = T_n + T_{n-1}$$

Square Number $T_n = n^2$

Pentagonal Number $T_n = \frac{n(3n-1)}{2}$

5.2 3D

Tetrahedral Number $T_n = \frac{n^3 + 3n^2 + 2n}{6}$

Square Pyramid Number $T_n = \frac{2n^3 + 3n^2 + n}{6}$

5.3 PERMUTATIONS

Permutations: $= n!$

Permutations (with repeats): $= \frac{n!}{(\text{groupA})! \times (\text{groupB})! \times \dots}$

5.4 COMBINATIONS

Ordered Combinations: $= \frac{n!}{(n-p)!}$

Unordered Combinations: $= \binom{n}{p} = \frac{n!}{p!(n-p)!}$

Ordered Repeated Combinations: $= n^p$

Unordered Repeated Combinations: $= \frac{(p+n-1)!}{p!(n-1)!}$

Grouping: $= \binom{n}{n_1} \binom{n-n_1}{n_2} \binom{n-n_1-n_2}{n_3} \dots = \frac{n!}{n_1!n_2!n_3!\dots n_r!}$

5.5 MISCELLANEOUS:

Total Number of Rectangles and Squares from a a x b rectangle:

$$\sum = T_a \times T_b$$

Number of Interpreters: $= T_{L-1}$

Max number of pizza pieces: $= \frac{c(c+1)}{2} + 1$

Max pieces of a crescent: $= \frac{c(c+3)}{2} + 1$

Max pieces of cheese: $= \frac{c^3 + 5c}{6} + 1$

Cards in a card house:
$$= \frac{l(3l+1)}{2}$$

Different arrangement of dominos:
$$= 2^{n-d} \times n!$$

Unit Fractions:
$$\frac{a}{b} = \frac{1}{\text{INT}\left[\frac{b}{a}\right]+1} + \frac{a - \text{MOD}\left[\frac{b}{a}\right]}{b\left(\text{INT}\left[\frac{b}{a}\right]+1\right)}$$

Angle between two hands of a clock:
$$\theta = 5.5m - 30h$$

Winning Lines in Noughts and Crosses:
$$= 2(a+1)$$

Bad Restaurant Spread:
$$= \frac{P}{1-s}$$

Fibonacci Sequence:
$$= \frac{1}{\sqrt{5}} \left(\left(\frac{1+\sqrt{5}}{2} \right)^n - \left(\frac{1-\sqrt{5}}{2} \right)^n \right)$$

ABBREVIATIONS (5.1, 5.2, 5.3, 5.4, 5.5)

a=side 'a'

b=side 'b'

c=cuts

d=double dominos

h=hours

L=Languages

l=layers

m=minutes

n= nth term

n=n number

P=Premium/Starting Quantity

p=number you pick

r=number of roles/turns

s=spread factor

T=Term

θ=the angle

5.6 FACTORIAL:

Definition:
$$n! = n \times (n-1) \times (n-2) \times \dots \times 2 \times 1$$

Table of Factorials:

0!	1 (by definition)		
1!	1	11!	39916800
2!	2	12!	479001600
3!	6	13!	6227020800
4!	24	14!	87178291200
5!	120	15!	1307674368000
6!	720	16!	20922789888000
7!	5040	17!	355687428096000

8!	40320	18!	6402373705728000
9!	362880	19!	121645100408832000
10!	3628800	20!	2432902008176640000

Approximation: $n! = \sqrt{2\pi} \times n^{n+\frac{1}{2}} \times e^{-n}$ (within 1% for $n > 10$)

5.7 THE DAY OF THE WEEK:

This only works after 1753

$$= \text{MOD}7 \left(d + y + \left[\frac{31m}{12} \right] + \left[\frac{y}{4} \right] - \left[\frac{y}{100} \right] + \left[\frac{y}{400} \right] \right)$$

d=day

m=month

y=year

SQUARE BRACKET MEAN INTEGER DIVISION

INT=Keep the integer

MOD=Keep the remainder

5.8 BASIC PROBABILITY:

$$\sum P = 1$$

5.9 VENN DIAGRAMS:

Complementary Events: $1 - P(A) = P(\bar{A})$

Totality: $P(A) = \sum_{i=1}^m P(A | B_i) P(B_i)$

$$P(A) = P(A \cap B) + P(A \cap B')$$

Conditional Probability: $P(A | B) = \frac{P(A \cap B)}{P(B)}$

$$P(A \cap B) = P(B) \cdot P(A | B)$$

Union : $P(A \cup B) = P(A) + P(B) - P(A \cap B)$

Independent Events: $P(A \cap B) = P(A) \cdot P(B)$

$$P(A \cup B) = P(A) + P(B) - P(A) \cdot P(B)$$

$$P(B | A) = P(B)$$

Mutually Exclusive: $P(A \cap B) = 0$

$$P(A \cap B') = P(A)$$

$$P(A \cup B) = P(A) + P(B)$$

$$P(A \cup B') = P(B')$$

Baye's Theorem:

$$P(B|A) = \frac{P(A|B)P(B)}{P(A)} = \frac{P(A|B)P(B)}{P(A|B)P(B) + P(A|B')P(B')}$$

Event's Space:

$$P(A) = \sum_{i=1}^m P(A \cap B_i)$$

5.11 BASIC STATISTICAL OPERATIONS:

Variance:

$$v = \sigma^2$$

Mean:

$$\mu = \frac{\sum x_i}{n_s}$$

Standardized Score:

$$z = \frac{x_i - \mu}{\sigma}$$

Confidence Interval:

5.12 DISCRETE RANDOM VARIABLES:

Standard Deviation:

$$\sigma = \sqrt{\frac{\sum (x_i - \bar{x})^2}{n_s}}$$

Expected Value:

$$E[X] = \sum_1^i P(x_i) \times x_i$$

$$E[aX + b] = aE[X] + b$$

Variance:

$$v = \frac{\sum (x_i - \bar{x})^2}{n_s}$$

$$v = (E[x - E[x]])^2$$

$$v = E[x^2] - (E[x])^2$$

$$\text{var}[aX + b] = a^2 \text{var}[X]$$

Probability Mass Function: $P(x) = f(x) = P(X = x)$

Cumulative Distribution Function: $F(x) = P(X \leq x)$

5.13 COMMON DRVs:

Bernoulli Trial:

Definition:

1 trial, 1 probability that is either fail or success

Outcomes:

$$S_X = \{0, 1\}$$

Probability:

$$P_X(x) = \begin{cases} p & x = 1 \\ 1 - p & x = 0 \end{cases}$$

Expected Value:

$$E[X] = p$$

Variance:

$$\text{Var}[X] = p - p^2 = p(1 - p)$$

Binomial Trial:

Definition:

Repeated Bernoulli Trials

Outcomes:

$$S_X = \{0, 1, 2, 3, \dots, n\}$$

Probability: $P_x(x) = \binom{n}{x} \cdot (p)^x \cdot (1-p)^{n-x}$

Expected Value: $E[X] = np$

Variance: $Var[X] = np(1-p)$

n=number to choose from
 p=probability of x occurring
 x=number of favorable results

Geometric Trial:

Definition: Number of Bernoulli Trials to get 1st Success.

Outcomes: $S_x = \{0,1,2,3,\dots\}$

Probability: $P_x(x) = p(1-p)^{x-1}$

Negative Binomial Trial:

Definition: Number to 1st get to n success.

Probability: $P_x(x) = \binom{x-1}{n-1} p^n (1-p)^{x-n}$

5.14 CONTINUOUS RANDOM VARIABLES:

Probability Density Function: = $f(x)$

$$\text{If } \int_{-\infty}^{\infty} f(x)dx = 1 \text{ \& } f(x) \geq 0 \text{ for } -\infty \leq x \leq \infty$$

Cumulative Distribution Function: = $F(x) = P(X \leq x) = \int_{-\infty}^x f(x)dx$

Interval Probability: $P(a \leq X \leq b) = F(b) - F(a) = \int_a^b f(x)dx$

Expected Value: $E(x) = \int_{-\infty}^{\infty} x \times f(x)dx$

$$E(g(x)) = \int_{-\infty}^{\infty} g(x) \times f(x)dx$$

Variance: $Var(X) = E(X^2) - (E(X))^2$

5.15 COMMON CRVs:

Uniform Distribution:

Declaration: $X \sim Uniform(a, b)$

PDF: $f(x) = \begin{cases} \frac{1}{b-a} & a \leq x \leq b \\ 0 & otherwise \end{cases}$

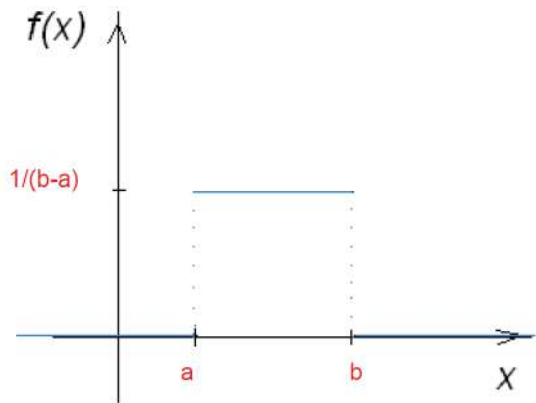

CDF:
$$F(x) = \int_{-\infty}^x f(x)dx = \begin{cases} 0 & x < a \\ \frac{x-a}{b-a} & a \leq x \leq b \\ 1 & x > b \end{cases}$$

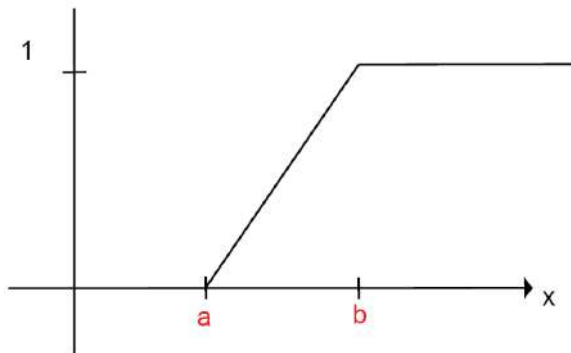

Expected Value:
$$= \frac{a+b}{2}$$

Variance:
$$= \frac{(b-a)^2}{12}$$

Exponential Distribution:

Declaration: $X \sim \text{Exponential}(\lambda)$

PDF:
$$f(x) = \begin{cases} 0 & x < 0 \\ \lambda e^{-\lambda x} & x \geq 0 \end{cases}$$

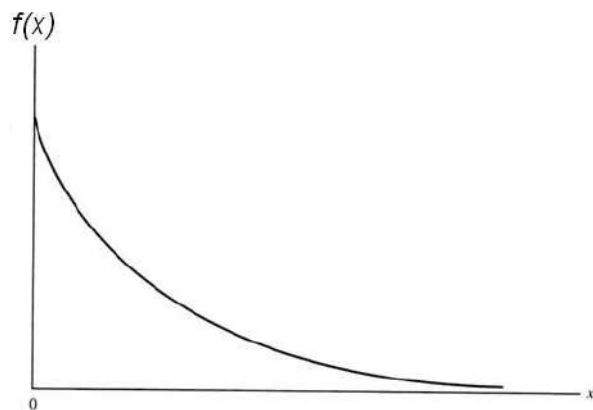

CDF:
$$F(x) = \int_{-\infty}^x f(x)dx = \begin{cases} 0 & x < 0 \\ 1 - e^{-\lambda x} & x \geq 0 \end{cases}$$

Expected Value:
$$= \frac{1}{\lambda}$$

Variance:
$$= \frac{1}{\lambda^2}$$

Normal Distribution:

Declaration:
$$X \sim Normal(\mu, \sigma^2)$$

Standardized Z Score:
$$Z = \frac{x - \mu}{\sigma}$$

PDF:
$$f(x) = \frac{1}{\sigma\sqrt{2\pi}} e^{-\frac{1}{2}\left(\frac{x-\mu}{\sigma}\right)^2} = \frac{1}{\sigma\sqrt{2\pi}} e^{-\frac{1}{2}z^2}$$

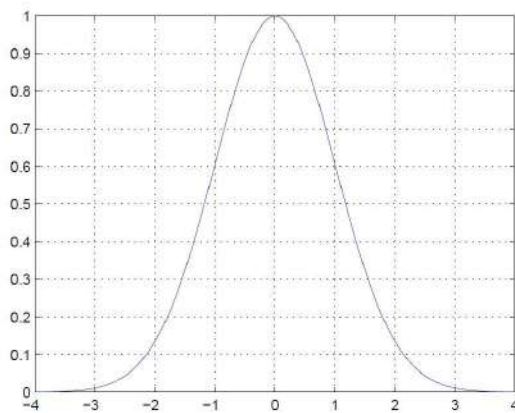

CDF:
$$\Phi(Z)$$
 (The integration is provided within statistic tables)

Expected Value:
$$= \mu$$

Variance:
$$= \sigma^2$$

5.16 MULTIVARIABLE DISCRETE:

Probability:

$$P(X = x, Y = y) = f(x, y)$$

$$P(X \leq x, Y \leq y) = \sum f(x, y) \text{ over all values of } x \text{ \& } y$$

Marginal Distribution:

$$f_X(x) = \sum_y f(x, y)$$

$$f_Y(y) = \sum_x f(x, y)$$

Expected Value:

$$E[X] = \sum_x x \times f_X(x)$$

$$E[Y] = \sum_y y \times f_Y(y)$$

$$E[X, Y] = \sum_x \sum_y x \times y \times f_{X,Y}(x, y)$$

Independence:

$$f(x, y) = f_X(x) \times f_Y(y)$$

Covariance: $Cov = E[X, Y] - E[X] \times E[Y]$

5.17 MULTIVARIABLE CONTINUOUS:

Probability:

$$P(X \leq x, Y \leq y) = \int_{-\infty}^y \int_{-\infty}^x f(x, y) dx dy$$

$$P(Y < y) = P(-\infty < X < \infty, Y < y) = \int_{-\infty}^y f_Y(y) dy$$

Marginal Distribution:

$$f_X(x) = \int_a^b f(x, y) dy \text{ where a \& b are bounds of y}$$

$$f_Y(y) = \int_a^b f(x, y) dx \text{ where a \& b are bounds of x}$$

Expected Value:

$$E[X] = \int_{-\infty}^{\infty} x \times f_X(x) dx$$

$$E[Y] = \int_{-\infty}^{\infty} y \times f_Y(y) dy$$

$$E[X, Y] = \int_{-\infty}^{\infty} \int_{-\infty}^{\infty} x \times y \times f_{X, Y}(x, y) dx dy$$

Independence:

$$f(x, y) = f_X(x) \times f_Y(y)$$

Covariance:

$$Cov = E[X, Y] - E[X] \times E[Y]$$

Correlation Coefficient:

$$\rho_{X, Y} = \frac{Cov(X, Y)}{\sigma_X \sigma_Y}$$

ABBREVIATIONS

σ = Standard Deviation

μ = mean

n_s = number of scores

p = probability of favourable result

v = variance

x_i = Individual x score

\bar{x} = mean of the x scores

z = Standardized Score

PART 6: FINANCIAL

6.1 GENERAL FORMUALS:

Profit:	$p = s - c$
Profit margin:	$m = \frac{p}{c} \times 100$
Simple Interest:	$= P(1 + tr)$
Compound Interest:	$= P(1 + r)^t$
Continuous Interest:	$= Pe^{rt}$

ABBREVIATIONS (6.1):

c=cost
I=interest
m=profit margin (%)
p=profit
P=premium
r=rate
s=sale price
t=time

6.2 MACROECONOMICS:

GDP:	$y = AE = AD = C + I + G + NX$ y = Summation of all product quantities multiplied by cost
RGDP:	RGDP = Summation of all product quantities multiplied by base year cost
NGDP:	NGDP = Summation of all product quantities multiplied by current year cost
Growth:	$\text{Growth} = \frac{RGDP_{CURRENT} - RGDP_{BASE}}{RGDP_{BASE}} \times 100$
Net Exports:	$NX = X - M$
Working Age Population:	WAP = Labor Force + Not in Labor Force
Labor Force:	LF = Employed + Unemployed
Unemployment:	UE = Frictional + Structural + Cyclical
Natural Unemployment:	NUE = Frictional + Structural
Unemployment Rate:	$\Delta UE\% = \frac{UE}{LF} \times 100$
Employment Rate:	$\Delta E\% = \frac{E}{LF} \times 100$
Participation Rate:	$\Delta P\% = \frac{LF}{WAP} \times 100 = \frac{UE + E}{WAP} \times 100$
CPI:	CPI = Indexed Average Price of all Goods and Services
Inflation Rate:	$\text{Inflation Rate} = \frac{CPI_{CURRENT} - CPI_{BASE}}{CPI_{BASE}} \times 100$

ABBREVIATIONS (6.2)

AD=Aggregate Demand

AE=Aggregate Expenditure
C=Consumption
CPI=Consumer Price Index
E=Employed
G=Government
I=Investment
LF=Labor Force
M=Imports
NGDP=Nominal GDP
NUE=Natural Unemployment
NX=Net Export
P=Participation
RGDP=Real GDP (Price is adjusted to base year)
UE=Unemployed
WAP=Working Age Population
X=Exports
Y=GDP

PART 7: PI

7.1 AREA:

Circle: $A = \pi r^2 = \frac{\pi d^2}{4} = \frac{Cd}{4}$

Cyclic Quadrilateral: $\sqrt{(s-a)(s-b)(s-c)(s-d)}$

Area of a sector (degrees) $A = \frac{Q}{360} \times \pi r^2$

Area of a sector (radians) $A = \frac{1}{2} r^2 \theta$

Area of a segment (degrees) $A = \frac{r^2}{2} \left(\frac{Q}{180} \times \pi - \sin Q \right)$

Area of an annulus: $A = \pi(r_2^2 - r_1^2) = \pi \left(\frac{w}{2} \right)^2$

Ellipse : $A = \frac{\pi}{4} lw = \pi r_1 r_2$

7.2 VOLUME:

Cylinder: $V = \pi r^2 h$

Sphere: $V = \frac{4}{3} \pi r^3$

Cap of a Sphere: $V = \frac{1}{6} \pi h (3r_1^2 + h^2)$

Cone: $V = \frac{1}{3} \pi r^2 h$

Ice-cream & Cone: $V = \frac{1}{3} \pi r^2 (h + 2r)$

Doughnut: $V = 2\pi^2 r_2 r_1^2 = \frac{\pi^2}{4} (b+a)(b-a)^2$

Sausage: $V = \frac{\pi w^2}{4} \left(l - \frac{w}{3} \right)$

Ellipsoid: $V = \frac{4}{3} \pi r_1 r_2 r_3$

7.3 SURFACE AREA:

Sphere: $SA = 4\pi r^2$

Hemisphere: $SA = 3\pi r^2$

Doughnut: $SA = 4\pi^2 r_2 r_1 = \pi^2 (b^2 - a^2)$

Sausage: $SA = \pi w l$

Cone: $SA = \pi r \left(r + \sqrt{r^2 + h^2} \right)$

7.4 MISCELLANEOUS:

Length of arc (degrees) $l = \frac{Q}{360} \times C = \frac{Q}{180} \times \pi r$

Length of chord (degrees) $l = 2r \times \sin\left(\frac{Q}{2}\right) = 2\sqrt{r^2 - h^2}$

Perimeter of an ellipse $P \approx \pi(r_1 + r_2) \left(\frac{1 + \frac{3(r_1 - r_2)^2}{(r_1 + r_2)^2}}{10 + \sqrt{4 - \frac{3(r_1 - r_2)^2}{(r_1 + r_2)^2}}} \right)$

7.6 PI:

$$\pi \approx 3.14159265358979323846264338327950288\dots$$

$$\pi = \frac{C}{d}$$

John Wallis: $\frac{\pi}{2} = \frac{2}{1} \times \frac{2}{3} \times \frac{4}{3} \times \frac{4}{5} \times \frac{6}{5} \times \frac{6}{7} \times \frac{8}{7} \times \frac{8}{9} \times \dots = \prod_{n=1}^{\infty} \frac{4n^2}{4n^2 - 1}$

Isaac Newton: $\frac{\pi}{6} = \frac{1}{2} + \frac{1}{2} \left(\frac{1}{3 \times 2^3} \right) + \frac{1 \times 3}{2 \times 4} \left(\frac{1}{5 \times 2^5} \right) + \frac{1 \times 3 \times 6}{2 \times 4 \times 6} \left(\frac{1}{7 \times 2^7} \right) + \dots$

James Gregory: $\frac{\pi}{4} = 1 - \frac{1}{3} + \frac{1}{5} - \frac{1}{7} + \frac{1}{9} - \frac{1}{11} + \frac{1}{13} - \frac{1}{15} \dots$

Leonard Euler: $\frac{\pi^2}{6} = \frac{1}{1^2} + \frac{1}{2^2} + \frac{1}{3^2} + \frac{1}{4^2} + \dots$

$$\frac{\pi}{4} = \frac{3}{4} \times \frac{5}{4} \times \frac{7}{8} \times \frac{11}{12} \times \frac{13}{12} \times \frac{17}{16} \times \frac{19}{20} \times \frac{23}{24} \times \frac{29}{28} \times \frac{31}{32} \times \dots$$

where the numerators are the odd primes; each denominator is the multiple of four nearest to the numerator.

$$\pi = 1 + \frac{1}{2} + \frac{1}{3} + \frac{1}{4} - \frac{1}{5} + \frac{1}{6} + \frac{1}{7} + \frac{1}{8} + \frac{1}{9} - \frac{1}{10} + \frac{1}{11} + \frac{1}{12} - \frac{1}{13} + \dots$$

If the denominator is a prime of the form $4m - 1$, the sign is positive; if the denominator is 2 or a prime of the form $4m + 1$, the sign is negative; for composite numbers, the sign is equal to the product of the signs of its factors.

Jozef Hoene-Wronski: $\pi = \lim_{n \rightarrow \infty} \frac{4n \left((1+i)^{\left(\frac{1}{n}\right)} - (1-i)^{\left(\frac{1}{n}\right)} \right)}{i}$

Franciscus Vieta: $\frac{2}{\pi} = \frac{\sqrt{2}}{2} \times \frac{\sqrt{2+\sqrt{2}}}{2} \times \frac{\sqrt{2+\sqrt{2+\sqrt{2}}}}{2} \times \dots$

Integrals:

$$\int_{-\infty}^{\infty} \operatorname{sech}(x) dx = \pi$$

$$\int_{-1}^1 \sqrt{1-x^2} dx = \frac{\pi}{2}$$

$$\int_{-1}^1 \frac{dx}{\sqrt{1-x^2}} = \pi$$

$$\int_{-\infty}^{\infty} \frac{dx}{1+x^2} = \pi$$

$$\int_{-\infty}^{\infty} e^{-x^2} dx = \sqrt{\pi}$$

$$\int_{-\infty}^{\infty} \frac{\sin(x)}{x} dx = \pi$$

$$\int_0^1 \frac{x^4(1-x)^4}{1+x^2} dx = \frac{22}{7} - \pi$$

Infinite Series:

$$\sum_{k=0}^{\infty} \frac{k!}{(2k+1)!!} = \sum_{k=0}^{\infty} \frac{2^k k!^2}{(2k+1)!} = \frac{\pi}{2}$$

$$12 \sum_{k=0}^{\infty} \frac{(-1)^k (6k)! (13591409 + 545140134k)}{(3k)! (k!)^3 640320^{3k+3/2}} = \frac{1}{\pi}$$

$$\frac{2\sqrt{2}}{9801} \sum_{k=0}^{\infty} \frac{(4k)! (1103 + 26390k)}{(k!)^4 396^{4k}} = \frac{1}{\pi}$$

$$\frac{\sqrt{3}}{6^5} \sum_{k=0}^{\infty} \frac{((4k)!)^2 (6k)!}{9^{k+1} (12k)! (2k)!} \left(\frac{127169}{12k+1} - \frac{1070}{12k+5} - \frac{131}{12k+7} + \frac{2}{12k+11} \right) = \pi$$

$$\sum_{k=0}^{\infty} \frac{1}{16^k} \left(\frac{4}{8k+1} - \frac{2}{8k+4} - \frac{1}{8k+5} - \frac{1}{8k+6} \right) = \pi$$

$$\frac{1}{2^6} \sum_{n=0}^{\infty} \frac{(-1)^n}{2^{10n}} \left(-\frac{2^5}{4n+1} - \frac{1}{4n+3} + \frac{2^8}{10n+1} - \frac{2^6}{10n+3} - \frac{2^2}{10n+5} - \frac{2^2}{10n+7} + \frac{1}{10n+9} \right) = \pi$$

See also: Zeta Function within [Part 17](#)

Continued Fractions:

$$\pi = 3 + \frac{1^2}{6 + \frac{3^2}{6 + \frac{5^2}{6 + \frac{7^2}{6 + \dots}}}}$$

$$\pi = \frac{4}{1 + \frac{1^2}{3 + \frac{2^2}{5 + \frac{3^2}{7 + \frac{4^2}{9 + \dots}}}}}$$

$$\pi = \frac{4}{1 + \frac{1^2}{2 + \frac{3^2}{2 + \frac{5^2}{2 + \frac{7^2}{2 + \dots}}}}}$$

7.7 CIRCLE GEOMETRY:

Radius of Circumscribed Circle for Rectangles: $r = \frac{\sqrt{a^2 + b^2}}{2}$

Radius of Circumscribed Circle for Squares: $r = \frac{a}{\sqrt{2}}$

Radius of Circumscribed Circle for Triangles: $r = \frac{a}{2 \sin A}$

Radius of Circumscribed Circle for Quadrilaterals:

$$r = \frac{1}{4} \times \sqrt{\frac{(ab + cd)(ac + bd)(ad + bc)}{(s - a)(s - b)(s - c)(s - d)}}$$

Radius of Inscribed Circle for Squares: $r = \frac{a}{2}$

Radius of Inscribed Circle for Triangles: $r = \frac{A}{s}$

Radius of Circumscribed Circle: $r = \frac{a}{2 \sin\left(\frac{180}{n}\right)}$

Radius of Inscribed Circle: $r = \frac{a}{2 \tan\left(\frac{180}{n}\right)}$

7.8 ABBREVIATIONS (7.1, 7.2, 7.3, 7.4, 7.5, 7.6, 7.7):

A=Angle 'A'

A=Area

a=side 'a'
 B=Angle 'B'
 b=side 'b'
 B=Angle 'B'
 c=side 'c'
 C=circumference
 d=diameter
 d=side 'd'
 h=shortest length from the center to the chord
 r=radius
 r₁=radius 1 (r₁ < r₂)
 r₂=radius 2 (r₂ < r₃)
 r₃=radius 3
 l=length
 n=number of sides
 P=perimeter
 Q=central angle
 s=semi-perimeter
 w=width
 w=length of chord from r₁

7.9 CRESCENT GEOMETRY:

Area of a lunar crescent: $A = \frac{1}{4} \pi cd$

Area of an eclipse crescent:

$$A = w^2 \left(\pi - \frac{2\pi \left(\cos^{-1} \left(\frac{w^2 + l^2 - b^2}{2wl} \right) \right)}{360} + \frac{\sin 2 \left(\cos^{-1} \left(\frac{w^2 + l^2 - b^2}{2wl} \right) \right)}{2} \right) \\
 - b^2 \left(\pi - \frac{2\pi \left(\cos^{-1} \left(\frac{w^2 + l^2 - b^2}{2wl} \right) \right)}{360} + \frac{\sin 2 \left(\cos^{-1} \left(\frac{w^2 + l^2 - b^2}{2wl} \right) \right)}{2} \right)$$

7.10 ABBREVIATIONS (7.9):

A=Area
 b=radius of black circle
 c=width of the crescent
 d=diameter
 l=distance between the centres of the circles
 w=radius of white circle

PART 8: PHYSICS

8.1 MOVEMENT:

Stopping distance: $s = \frac{v^2}{-2a}$

Centripetal acceleration: $a = \frac{v^2}{r}$

Centripetal force: $F_C = ma = \frac{mv^2}{r}$

Dropping time : $t = \sqrt{\frac{2h}{g}}$

Force: $F = \frac{ma}{\left(1 - \frac{v^2}{c^2}\right)^{\frac{3}{2}}}$

Kinetic Energy: $E_k = \frac{1}{2}mv^2$

Maximum height of a cannon: $h = \frac{(u \sin \theta)^2}{g}$

Pendulum swing time: $t = 2\pi \sqrt{\frac{l}{g}}$

Potential Energy: $E_p = mgh$

Range of a cannon: $s = t(u \cos \theta) = \frac{2u \sin \theta}{g} \times (u \cos \theta)$

Time in flight of a cannon: $t = \frac{2u \sin \theta}{g}$

Universal Gravitation: $F = G \frac{m_1 m_2}{r^2}$

ABBREVIATIONS (8.1):

a=acceleration (negative if retarding)

c=speed of light ($3 \times 10^8 \text{ ms}^{-1}$)

E_k =Kinetic Energy

E_p =potential energy

F=force

g=gravitational acceleration (≈ 9.81 on Earth)

G=gravitational constant = 6.67×10^{-11}

h=height

l=length of a pendulum

m=mass

m_1 =mass 1

m_2 =mass 2

r =radius
 r =distance between two points
 s =distance
 t =time
 u =initial speed
 v =final speed
 θ =the angle

8.2 CLASSICAL MECHANICS:

Newton's Laws:

First law: If an object experiences no net force, then its velocity is constant; the object is either at rest (if its velocity is zero), or it moves in a straight line with constant speed (if its velocity is nonzero).

$$\sum \mathbf{F} = 0 \Rightarrow \frac{d\mathbf{v}}{dt} = 0.$$

Second law: The acceleration a of a body is parallel and directly proportional to the net force F acting on the body, is in the direction of the net force, and is inversely proportional to the mass m of the body, i.e., $F = ma$.

$$\mathbf{F} = \frac{d\mathbf{p}}{dt} = \frac{d(m\mathbf{v})}{dt}.$$

$$\mathbf{J} = \int_{\Delta t} \mathbf{F} dt.$$

$$\mathbf{J} = \Delta \mathbf{p} = m\Delta \mathbf{v}.$$

$$\mathbf{F} + \mathbf{u} \frac{dm}{dt} = m \frac{d\mathbf{v}}{dt}$$

$$\mathbf{F} = m\mathbf{a}.$$

Third law: When two bodies interact by exerting force on each other, these forces (termed the action and the reaction) are equal in magnitude, but opposite in direction.

$$\sum \mathbf{F}_{a,b} = - \sum \mathbf{F}_{b,a}$$

Inertia:

$$p = mv$$

$$p = p_1 + p_2$$

$$\Delta p = F\Delta t = m_1v_1 + m_2v_2.$$

$$\Delta p = \int_{t_1}^{t_2} F(t) dt.$$

$$\frac{dp_1}{dt} = - \frac{dp_2}{dt},$$

$$\frac{d}{dt} (p_1 + p_2) = 0.$$

$$m_1u_1 + m_2u_2 = m_1v_1 + m_2v_2$$

$$\frac{1}{2}m_1u_1^2 + \frac{1}{2}m_2u_2^2 = \frac{1}{2}m_1v_1^2 + \frac{1}{2}m_2v_2^2.$$

$$v_1 = \left(\frac{m_1 - m_2}{m_1 + m_2} \right) u_1 + \left(\frac{2m_2}{m_1 + m_2} \right) u_2$$

$$v_2 = \left(\frac{m_2 - m_1}{m_1 + m_2} \right) u_2 + \left(\frac{2m_1}{m_1 + m_2} \right) u_1.$$

$$p_x = mv_x$$

$$p_y = mv_y$$

$$p_z = mv_z.$$

Moments of Inertia:

$$I_{\text{net}} = \sum_j I_j$$

$$I_d = I_{\text{com}} + Md^2$$

$$I_k \leq I_i + I_j$$

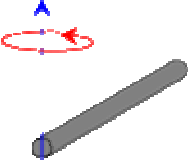
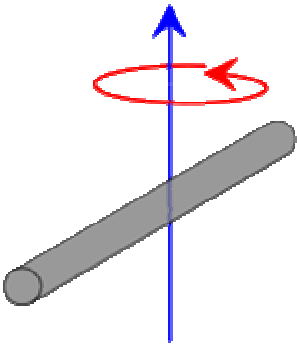
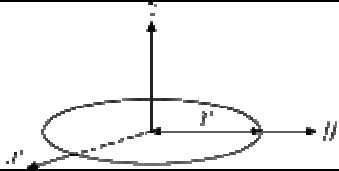
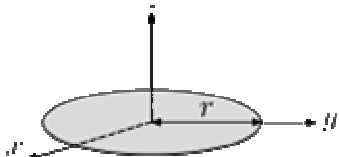
Description	Diagram	Formulae
Two point masses, M and m , with reduced mass μ and separated by a distance, x .		$I = mr^2$
Rod of length L and mass m (Axis of rotation at the end of the rod)		$I = \frac{Mm}{M+m}x^2 = \mu x^2$
Rod of length L and mass m		$I_{\text{end}} = \frac{mL^2}{3}$
Thin circular hoop of radius r and mass m		$I_{\text{center}} = \frac{mL^2}{12}$
Thin circular hoop of radius r and mass m		$I_z = mr^2$ $I_x = I_y = \frac{mr^2}{2}$
Thin, solid disk of radius r and mass m		$I_z = \frac{mr^2}{2}$ $I_x = I_y = \frac{mr^2}{4}$

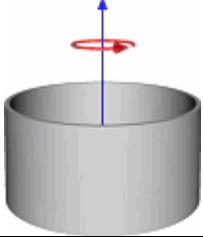
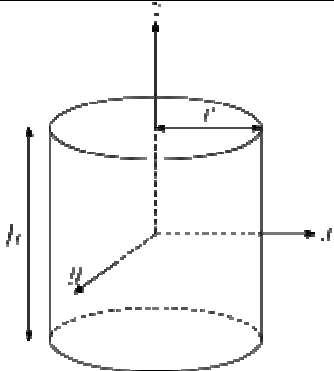
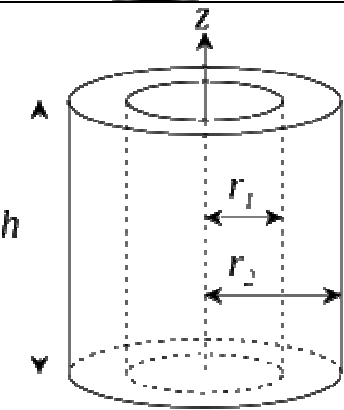
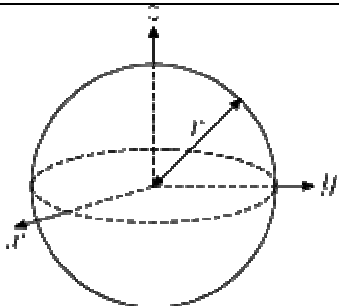
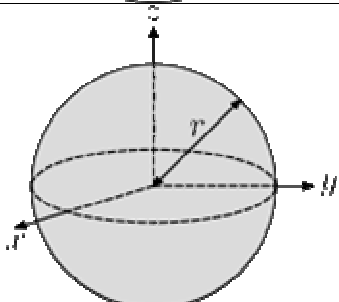
Thin cylindrical shell with open ends, of radius r and mass m		$I = mr^2$
Solid cylinder of radius r , height h and mass m		$I_z = \frac{mr^2}{2}$ $I_x = I_y = \frac{1}{12}m(3r^2 + h^2)$
Thick-walled cylindrical tube with open ends, of inner radius r_1 , outer radius r_2 , length h and mass m		$I_z = \frac{1}{2}m(r_1^2 + r_2^2)$ $I_x = I_y = \frac{1}{12}m[3(r_2^2 + r_1^2) + h^2]$ <p>or when defining the normalized thickness $t_n = t/r$ and letting $r = r_2$,</p> $\text{then } I_z = mr^2 \left(1 - t_n + \frac{1}{2}t_n^2 \right)$
Sphere (hollow) of radius r and mass m		$I = \frac{2mr^2}{3}$
Ball (solid) of radius r and mass m		$I = \frac{2mr^2}{5}$

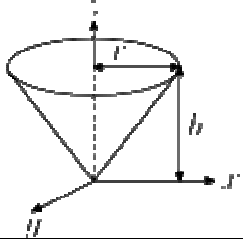
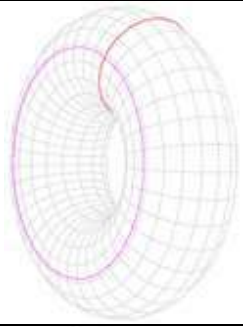
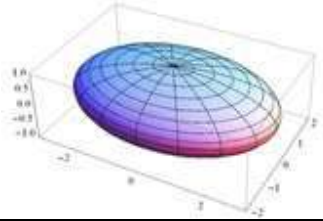
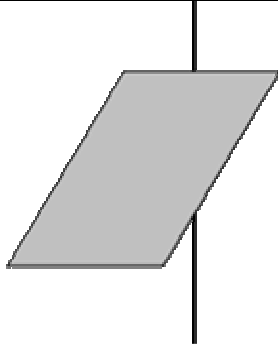
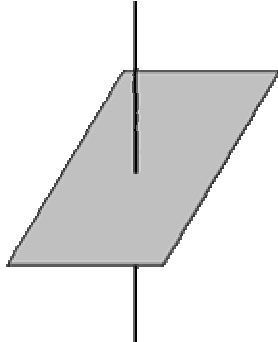
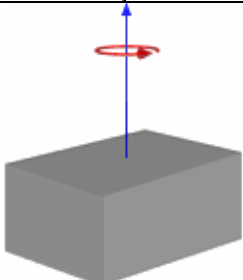
<p>Right circular cone with radius r, height h and mass m</p>		$I_z = \frac{3}{10}mr^2$ $I_x = I_y = \frac{3}{5}m \left(\frac{r^2}{4} + h^2 \right)$
<p>Torus of tube radius a, cross-sectional radius b and mass m.</p>		<p>About a diameter: $\frac{1}{8} (4a^2 + 5b^2) m$</p> <p>About the vertical axis: $\left(a^2 + \frac{3}{4}b^2 \right) m$</p>
<p>Ellipsoid (solid) of semiaxes a, b, and c with axis of rotation a and mass m</p>		$I_a = \frac{m(b^2 + c^2)}{5}$
<p>Thin rectangular plate of height h and of width w and mass m (Axis of rotation at the end of the plate)</p>		$I_e = \frac{mh^2}{3} + \frac{mw^2}{12}$
<p>Thin rectangular plate of height h and of width w and mass m</p>		$I_c = \frac{m(h^2 + w^2)}{12}$
<p>Solid cuboid of height h, width w, and depth d, and mass m</p>		$I_h = \frac{1}{12}m (w^2 + d^2)$ $I_w = \frac{1}{12}m (h^2 + d^2)$ $I_d = \frac{1}{12}m (h^2 + w^2)$

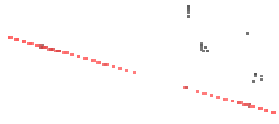
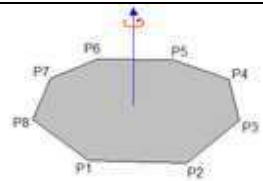
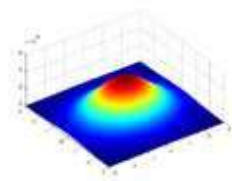
<p>Solid cuboid of height D, width W, and length L, and mass m with the longest diagonal as the axis.</p>		$I = \frac{m(W^2D^2 + L^2D^2 + L^2W^2)}{6(L^2 + W^2 + D^2)}$
<p>Plane polygon with vertices $\vec{P}_1, \vec{P}_2, \vec{P}_3, \dots, \vec{P}_N$ and mass m uniformly distributed on its interior, rotating about an axis perpendicular to the plane and passing through the origin.</p>		$I = \frac{m \sum_{n=1}^{N-1} \ \vec{P}_{n+1} \times \vec{P}_n\ ((\vec{P}_{n+1} \cdot \vec{P}_{n+1}) + (\vec{P}_{n+1} \cdot \vec{P}_n) + (\vec{P}_n \cdot \vec{P}_n))}{6 \sum_{n=1}^{N-1} \ \vec{P}_{n+1} \times \vec{P}_n\ }$
<p>Infinite disk with mass normally distributed on two axes around the axis of rotation (i.e. $\rho(x, y) = \frac{m}{2\pi ab} e^{-\frac{x^2}{a^2} - \frac{y^2}{b^2}}$ Where: $\rho(x, y)$ is the mass-density as a function of x and y).</p>		$I = m(a^2 + b^2)$

Velocity and Speed:

$$v_{AVE} = \frac{\Delta P}{\Delta t}$$

$$\mathbf{V} = \lim_{\Delta t \rightarrow 0} \frac{\Delta \mathbf{P}}{\Delta t} = \frac{d\mathbf{P}}{dt} = \dot{\mathbf{P}} = \dot{x}_p \vec{i} + \dot{y}_p \vec{j} + \dot{z}_p \vec{k}.$$

$$|\mathbf{V}| = |\dot{\mathbf{P}}| = \frac{ds}{dt},$$

$$\mathbf{V}(t) = \int_0^t \mathbf{A} dt = \mathbf{A}t + \mathbf{V}_0.$$

$$v^2 = v_x^2 + v_y^2 + v_z^2.$$

Acceleration:

$$a_{AVE} = \frac{\Delta V}{\Delta t}$$

$$\mathbf{A} = \lim_{\Delta t \rightarrow 0} \frac{\Delta \mathbf{V}}{\Delta t} = \frac{d\mathbf{V}}{dt} = \dot{\mathbf{V}} = \ddot{\mathbf{P}} = \ddot{x}_p \vec{i} + \ddot{y}_p \vec{j} + \ddot{z}_p \vec{k}.$$

Trajectory (Displacement):

$$\mathbf{P}(t) = \int_0^t \mathbf{V}(t) dt = \int (\mathbf{A}t + \mathbf{V}_0) dt = \frac{1}{2} \mathbf{A}t^2 + \mathbf{V}_0 t + \mathbf{P}_0.$$

$$\mathbf{P}(t) = \mathbf{P}_0 + \left(\frac{\mathbf{V} + \mathbf{V}_0}{2} \right) t.$$

$$(\mathbf{P} - \mathbf{P}_0) \cdot \mathbf{A}t = (\mathbf{V} - \mathbf{V}_0) \cdot \frac{\mathbf{V} + \mathbf{V}_0}{2} t.$$

Kinetic Energy:

$$E_k = \frac{1}{2}mv^2$$

$$E_k = \frac{p^2}{2m}$$

$$E_k = \int \mathbf{F} \cdot d\mathbf{x} = \int \mathbf{v} \cdot d(m\mathbf{v}) = \int d\left(\frac{mv^2}{2}\right) = \frac{mv^2}{2}.$$

$$E_k = E_i + \frac{MV^2}{2}.$$

$$E_r = \int \frac{v^2 dm}{2} = \int \frac{(r\omega)^2 dm}{2} = \frac{\omega^2}{2} \int r^2 dm = \frac{\omega^2}{2} I = \frac{1}{2} I \omega^2$$

Centripetal Force:

$$F = ma_c = \frac{mv^2}{r}$$

$$F = mr\omega^2$$

$$F = mr \frac{4\pi^2}{T^2}.$$

Circular Motion:

$$\omega = \frac{2\pi}{T} = 2\pi f = \frac{|v|}{|r|}.$$

$$\omega_{cyc} = \omega_{rad}/2\pi$$

$$\omega_{cyc} = \omega_{deg}/360$$

$$v = \frac{2\pi r}{T} = \omega r$$

$$\theta = 2\pi \frac{t}{T} = \omega t$$

$$a = \frac{v^2}{r}$$

$$\alpha = \frac{d\omega}{dt} = \frac{d^2\theta}{dt^2}, \text{ or}$$

$$\alpha = \frac{a_T}{r},$$

$$\alpha = \frac{\tau}{I}.$$

Angular Momentum:

$$\mathbf{L} = I\boldsymbol{\omega}.$$

$$\mathbf{L} = \mathbf{r} \times m\mathbf{v}.$$

$$\mathbf{L} = \mathbf{r} \times \mathbf{p}$$

$$\mathbf{L} = \sum \mathbf{R}_i \times m_i \mathbf{V}_i$$

$$\mathbf{L} = \sum_i \mathbf{R}_i \times m_i \mathbf{V}_i$$

Torque:

$$\boldsymbol{\tau} = \frac{d\mathbf{L}}{dt} = \frac{d\mathbf{r}}{dt} \times \mathbf{p} + \mathbf{r} \times \frac{d\mathbf{p}}{dt} = 0 + \mathbf{r} \times \mathbf{F} = \mathbf{r} \times \mathbf{F}$$

$$\tau = rF \sin \theta$$

$$\tau_{\text{net}} = \frac{d\mathbf{L}}{dt} = \frac{d(I\boldsymbol{\omega})}{dt} = I \frac{d\boldsymbol{\omega}}{dt} = I\boldsymbol{\alpha},$$

$$|\tau| = (\text{moment arm})(\text{force}).$$

Work:

$$W = \int_{\theta_1}^{\theta_2} \tau \, d\theta,$$

Laws of Conservation:

Momentum: $\frac{d}{dt} (p_1 + p_2) = 0.$

Energy: $\sum E_{IN} = \sum E_{OUT}$

Force: $\sum F_{NET} = 0 \Rightarrow \sum F_{UP} = \sum F_{DN}, \sum F_L = \sum F_R, \sum cm = \sum acm$

ABBREVIATIONS (8.2)

a=acceleration

E_K =Kinetic Energy

E_r =rotational kinetic energy

F=force

I=mass moment of inertia

J=impulse

L=angular momentum

m=mass

P=path

p=momentum

t=time

v=velocity

W=work

τ =torque

8.3 RELATIVISTIC EQUATIONS:

Kinetic Energy:

$$E_k = \frac{mc^2}{\sqrt{1 - (v/c)^2}} - mc^2$$

Momentum:

$$p = \frac{mv}{\sqrt{1 - (v/c)^2}}$$

Time Dilation:

$$\Delta t' = \frac{\Delta t}{\sqrt{1 - v^2/c^2}}$$

Length Contraction:

$$L = L_0 \cdot \sqrt{1 - \frac{v^2}{c^2}}$$

Relativistic Mass:

$$m = \frac{m_0 c^2}{\sqrt{1 - \frac{v^2}{c^2}}}$$

PART 9: TRIGONOMETRY

9.1 CONVERSIONS:

Degrees	30°	60°	120°	150°	210°	240°	300°	330°
Radians	$\frac{\pi}{6}$	$\frac{\pi}{3}$	$\frac{2\pi}{3}$	$\frac{5\pi}{6}$	$\frac{7\pi}{6}$	$\frac{4\pi}{3}$	$\frac{5\pi}{3}$	$\frac{11\pi}{6}$
Grads	33 $\frac{1}{3}$ grad	66 $\frac{2}{3}$ grad	133 $\frac{1}{3}$ grad	166 $\frac{2}{3}$ grad	233 $\frac{1}{3}$ grad	266 $\frac{2}{3}$ grad	333 $\frac{1}{3}$ grad	366 $\frac{2}{3}$ grad
Degrees	45°	90°	135°	180°	225°	270°	315°	360°
Radians	$\frac{\pi}{4}$	$\frac{\pi}{2}$	$\frac{3\pi}{4}$	π	$\frac{5\pi}{4}$	$\frac{3\pi}{2}$	$\frac{7\pi}{4}$	2π
Grads	50 grad	100 grad	150 grad	200 grad	250 grad	300 grad	350 grad	400 grad

9.2 BASIC RULES:

$$\tan \theta = \frac{\sin \theta}{\cos \theta}$$

Sin Rule:

$$\frac{a}{\sin A} = \frac{b}{\sin B} = \frac{c}{\sin C} \text{ or } \frac{\sin A}{a} = \frac{\sin B}{b} = \frac{\sin C}{c}$$

Cos Rule:

$$\cos A = \frac{b^2 + c^2 - a^2}{2bc} \text{ or } a^2 = b^2 + c^2 - 2bc \cos A$$

Tan Rule:

$$\frac{\tan \frac{A-B}{2}}{\tan \frac{A+B}{2}} = \frac{a-b}{a+b}$$

$$\frac{\tan \frac{A-C}{2}}{\tan \frac{A+C}{2}} = \frac{a-c}{a+c}$$

$$\frac{\tan \frac{B-C}{2}}{\tan \frac{B+C}{2}} = \frac{b-c}{b+c}$$

Auxiliary Angle:

$$a \sin x \pm b \cos x = R \sin (x \pm \alpha), \quad 0 < \alpha < \frac{\pi}{2}$$

$$\text{where } R^2 = a^2 + b^2, \quad \tan \alpha = \frac{b}{a}$$

Pythagoras Theorem:

$$a^2 + b^2 = c^2$$

9.3 RECIPROCAL FUNCTIONS

$$\sec \theta = \frac{1}{\cos \theta}$$

$$\csc \theta = \frac{1}{\sin \theta}$$

$$\cot \theta = \frac{1}{\tan \theta} = \frac{\cos \theta}{\sin \theta}$$

9.4 BASIC IDENTITIES:

Pythagorean Identity: $\cos^2 \theta + \sin^2 \theta = 1$

$$\begin{aligned}\sin(-\theta) &= -\sin \theta \\ \cos(-\theta) &= +\cos \theta \\ \tan(-\theta) &= -\tan \theta \\ \csc(-\theta) &= -\csc \theta \\ \sec(-\theta) &= +\sec \theta \\ \cot(-\theta) &= -\cot \theta \\ \sin\left(\frac{\pi}{2} - \theta\right) &= +\cos \theta \\ \cos\left(\frac{\pi}{2} - \theta\right) &= +\sin \theta \\ \tan\left(\frac{\pi}{2} - \theta\right) &= +\cot \theta \\ \csc\left(\frac{\pi}{2} - \theta\right) &= +\sec \theta \\ \sec\left(\frac{\pi}{2} - \theta\right) &= +\csc \theta \\ \cot\left(\frac{\pi}{2} - \theta\right) &= +\tan \theta \\ \sin(\pi - \theta) &= +\sin \theta \\ \cos(\pi - \theta) &= -\cos \theta \\ \tan(\pi - \theta) &= -\tan \theta \\ \csc(\pi - \theta) &= +\csc \theta \\ \sec(\pi - \theta) &= -\sec \theta \\ \cot(\pi - \theta) &= -\cot \theta\end{aligned}$$

9.5 IDENTITIES (SINΘ):

- $\frac{\sin \theta}{\tan \theta}$
- $\pm \sqrt{1 - \cos^2 \theta}$
- $\frac{\pm \sqrt{1 + \tan^2 \theta}}{1}$
- $\frac{\csc \theta}{\sqrt{\sec^2 \theta - 1}}$
- $\pm \frac{\sec \theta}{\sec \theta}$

$$\bullet \pm \frac{1}{\sqrt{1 + \cot^2 \theta}}$$

9.6 IDENTITIES (COS θ):

$$\bullet \pm \sqrt{1 - \sin^2 \theta}$$

$$\bullet \cos \theta$$

$$\bullet \pm \frac{1}{\sqrt{1 + \tan^2 \theta}}$$

$$\bullet \pm \frac{\sqrt{\csc^2 \theta - 1}}{\csc \theta}$$

$$\bullet \frac{1}{\sec \theta}$$

$$\bullet \frac{\cot \theta}{\sqrt{1 + \cot^2 \theta}}$$

9.7 IDENTITIES (TAN θ):

$$\bullet \pm \frac{\sin \theta}{\sqrt{1 - \sin^2 \theta}}$$

$$\bullet \pm \frac{\sqrt{1 - \cos^2 \theta}}{\cos \theta}$$

$$\bullet \tan \theta$$

$$\bullet \pm \frac{1}{\sqrt{\csc^2 \theta - 1}}$$

$$\bullet \pm \frac{\sqrt{\sec^2 \theta - 1}}{1}$$

$$\bullet \frac{1}{\cot \theta}$$

9.8 IDENTITIES (CSC θ):

$$\bullet \frac{1}{\sin \theta}$$

$$\bullet \pm \frac{1}{\sqrt{1 - \cos^2 \theta}}$$

$$\bullet \pm \frac{\sqrt{1 + \tan^2 \theta}}{\tan \theta}$$

$$\bullet \csc \theta$$

$$\bullet \frac{\sec \theta}{\sqrt{\sec^2 \theta - 1}}$$

$$\bullet \pm \sqrt{1 + \cot^2 \theta}$$

9.9 IDENTITIES (COT θ):

$$\bullet \pm \frac{\sqrt{1 - \sin^2 \theta}}{\sin \theta}$$

- $\frac{\pm \cos \theta}{\sqrt{1 - \cos^2 \theta}}$
- $\frac{\tan \theta}{\pm \sqrt{\csc^2 \theta - 1}}$
- $\frac{\pm \cot \theta}{\sqrt{\sec^2 \theta - 1}}$

9.10 ADDITION FORMULAE:

Sine: $\sin(\alpha \pm \beta) = \sin \alpha \cos \beta \pm \cos \alpha \sin \beta$

Cosine: $\cos(\alpha \pm \beta) = \cos \alpha \cos \beta \mp \sin \alpha \sin \beta$

Tangent: $\tan(\alpha \pm \beta) = \frac{\tan \alpha \pm \tan \beta}{1 \mp \tan \alpha \tan \beta}$

Arcsine:

$$\arcsin \alpha \pm \arcsin \beta = \arcsin(\alpha \sqrt{1 - \beta^2} \pm \beta \sqrt{1 - \alpha^2})$$

Arccosine:

$$\arccos \alpha \pm \arccos \beta = \arccos(\alpha \beta \mp \sqrt{(1 - \alpha^2)(1 - \beta^2)})$$

$$\arctan \alpha \pm \arctan \beta = \arctan \left(\frac{\alpha \pm \beta}{1 \mp \alpha \beta} \right)$$

Arctangent:

9.11 DOUBLE ANGLE FORMULAE:

Sine:

$$\begin{aligned} \sin 2\theta &= 2 \sin \theta \cos \theta \\ &= \frac{2 \tan \theta}{1 + \tan^2 \theta} \end{aligned}$$

Generally,

$$\sin(nx) = \sum_{k=0}^n \binom{n}{k} \cos^k(x) \sin^{n-k}(x) \sin\left(\frac{1}{2}(n-k)\pi\right)$$

Cosine:

$$\begin{aligned} \cos 2\theta &= \cos^2 \theta - \sin^2 \theta \\ &= 2 \cos^2 \theta - 1 \\ &= 1 - 2 \sin^2 \theta \\ &= \frac{1 - \tan^2 \theta}{1 + \tan^2 \theta} \end{aligned}$$

Generally,

$$\cos(nx) = \sum_{k=0}^n \binom{n}{k} \cos^k(x) \sin^{n-k}(x) \cos\left(\frac{1}{2}(n-k)\pi\right)$$

Tangent:

$$\tan 2\theta = \frac{2 \tan \theta}{1 - \tan^2 \theta}$$

Generally,

$$\tan(nx) = \frac{\sin(nx)}{\cos(nx)} = \frac{\sum_{k=0}^n \binom{n}{k} \cos^k(x) \sin^{n-k}(x) \sin\left(\frac{1}{2}(n-k)\pi\right)}{\sum_{k=0}^n \binom{n}{k} \cos^k(x) \sin^{n-k}(x) \cos\left(\frac{1}{2}(n-k)\pi\right)}$$

Cot:

$$\cot 2\theta = \frac{\cot^2 \theta - 1}{2 \cot \theta}$$

9.12 TRIPLE ANGLE FORMULAE:

Sine:

$$\sin 3\theta = 3 \sin \theta - 4 \sin^3 \theta$$

Cosine:

$$\cos 3\theta = 4 \cos^3 \theta - 3 \cos \theta$$

Tangent:

$$\tan 3\theta = \frac{3 \tan \theta - \tan^3 \theta}{1 - 3 \tan^2 \theta}$$

Cot:

$$\cot 3\theta = \frac{3 \cot \theta - \cot^3 \theta}{1 - 3 \cot^2 \theta}$$

9.13 HALF ANGLE FORMULAE:

Sine:

$$\sin \frac{\theta}{2} = \pm \sqrt{\frac{1 - \cos \theta}{2}}$$

Cosine:

$$\cos \frac{\theta}{2} = \pm \sqrt{\frac{1 + \cos \theta}{2}}$$

Tangent:

$$\begin{aligned} \tan \frac{\theta}{2} &= \csc \theta - \cot \theta \\ &= \pm \sqrt{\frac{1 - \cos \theta}{1 + \cos \theta}} \\ &= \frac{\sin \theta}{1 + \cos \theta} \\ &= \frac{1 - \cos \theta}{\sin \theta} \end{aligned}$$

Cot:

$$\begin{aligned}\cot \frac{\theta}{2} &= \csc \theta + \cot \theta \\ &= \pm \sqrt{\frac{1 + \cos \theta}{1 - \cos \theta}} \\ &= \frac{\sin \theta}{1 - \cos \theta} \\ &= \frac{1 + \cos \theta}{\sin \theta}\end{aligned}$$

9.14 POWER REDUCTION:

Sine:

$$\begin{aligned}\sin^2 \theta &= \frac{1 - \cos 2\theta}{2} \\ \sin^3 \theta &= \frac{3 \sin \theta - \sin 3\theta}{4} \\ \sin^4 \theta &= \frac{3 - 4 \cos 2\theta + \cos 4\theta}{8} \\ \sin^5 \theta &= \frac{10 \sin \theta - 5 \sin 3\theta + \sin 5\theta}{16}\end{aligned}$$

If n is even:

$$\sin^n \theta = \frac{1}{2^n} \binom{n}{\frac{n}{2}} + \frac{2}{2^n} \sum_{k=0}^{\frac{n}{2}-1} (-1)^{\binom{n}{2}-k} \binom{n}{k} \cos((n-2k)\theta)$$

If n is odd:

$$\sin^n \theta = \frac{2}{2^n} \sum_{k=0}^{\frac{n-1}{2}} (-1)^{\binom{n-1}{2}-k} \binom{n}{k} \sin((n-2k)\theta)$$

Cosine:

$$\begin{aligned}\cos^2 \theta &= \frac{1 + \cos 2\theta}{2} \\ \cos^3 \theta &= \frac{3 \cos \theta + \cos 3\theta}{4} \\ \cos^4 \theta &= \frac{3 + 4 \cos 2\theta + \cos 4\theta}{8} \\ \cos^5 \theta &= \frac{10 \cos \theta + 5 \cos 3\theta + \cos 5\theta}{16}\end{aligned}$$

If n is even:

$$\cos^n \theta = \frac{2}{2^n} \sum_{k=0}^{\frac{n}{2}} \binom{n}{k} \cos((n-2k)\theta)$$

If n is odd:

$$\cos^n \theta = \frac{1}{2^n} \binom{n}{\frac{n}{2}} + \frac{2}{2^n} \sum_{k=0}^{\frac{n}{2}-1} \binom{n}{k} \cos((n-2k)\theta)$$

Sine & Cosine:

$$\sin^2 \theta \cos^2 \theta = \frac{1 - \cos 4\theta}{8}$$

$$\sin^3 \theta \cos^3 \theta = \frac{3 \sin 2\theta - \sin 6\theta}{32}$$

$$\sin^4 \theta \cos^4 \theta = \frac{3 - 4 \cos 4\theta + \cos 8\theta}{128}$$

$$\sin^5 \theta \cos^5 \theta = \frac{10 \sin 2\theta - 5 \sin 6\theta + \sin 10\theta}{512}$$

9.15 PRODUCT TO SUM:

$$\cos \theta \cos \varphi = \frac{\cos(\theta - \varphi) + \cos(\theta + \varphi)}{2}$$

$$\sin \theta \sin \varphi = \frac{\cos(\theta - \varphi) - \cos(\theta + \varphi)}{2}$$

$$\sin \theta \cos \varphi = \frac{\sin(\theta + \varphi) + \sin(\theta - \varphi)}{2}$$

$$\cos \theta \sin \varphi = \frac{\sin(\theta + \varphi) - \sin(\theta - \varphi)}{2}$$

9.16 SUM TO PRODUCT:

$$\sin \theta \pm \sin \varphi = 2 \sin \left(\frac{\theta \pm \varphi}{2} \right) \cos \left(\frac{\theta \mp \varphi}{2} \right)$$

$$\cos \theta + \cos \varphi = 2 \cos \left(\frac{\theta + \varphi}{2} \right) \cos \left(\frac{\theta - \varphi}{2} \right)$$

$$\cos \theta - \cos \varphi = -2 \sin \left(\frac{\theta + \varphi}{2} \right) \sin \left(\frac{\theta - \varphi}{2} \right)$$

9.17 HYPERBOLIC EXPRESSIONS:

Hyperbolic sine: $\sinh x = \frac{e^x - e^{-x}}{2}$

Hyperbolic cosine: $\cosh x = \frac{e^x + e^{-x}}{2}$

Hyperbolic tangent: $\tanh x = \frac{\sinh x}{\cosh x} = \frac{\frac{1}{2}(e^x - e^{-x})}{\frac{1}{2}(e^x + e^{-x})} = \frac{e^{2x} - 1}{e^{2x} + 1}$

Hyperbolic cotangent: $\coth x = \frac{\cosh x}{\sinh x} = \frac{\frac{1}{2}(e^x + e^{-x})}{\frac{1}{2}(e^x - e^{-x})} = \frac{e^{2x} + 1}{e^{2x} - 1}$

Hyperbolic secant: $\operatorname{sech} x = \frac{1}{\cosh x} = \frac{2}{e^x + e^{-x}}$

Hyperbolic cosecant: $\operatorname{csch} x = \frac{1}{\sinh x} = \frac{2}{e^x - e^{-x}}$

9.18 HYPERBOLIC RELATIONS:

$$\cosh^2 x - \sinh^2 x = 1$$

$$\sinh(-x) = -\sinh x$$

$$\cosh(-x) = \cosh x$$

$$\tanh(-x) = -\tanh x$$

$$\operatorname{coth}(-x) = -\operatorname{coth} x$$

$$\operatorname{sech}(-x) = \operatorname{sech} x$$

$$\operatorname{csch}(-x) = -\operatorname{csch} x$$

$$\operatorname{arsech} x = \operatorname{arcosh} \frac{1}{x}$$

$$\operatorname{arsch} x = \operatorname{arsinh} \frac{1}{x}$$

$$\operatorname{arcoth} x = \operatorname{artanh} \frac{1}{x}$$

9.19 MACHIN-LIKE FORMULAE:

Form:

$$\frac{\pi}{4} = \sum_n^N a_n \arctan \frac{1}{b_n}$$

Formulae:

$$\frac{\pi}{4} = 4 \arctan \frac{1}{5} - \arctan \frac{1}{239}$$

$$\frac{\pi}{4} = \arctan \frac{1}{2} + \arctan \frac{1}{3}$$

$$\frac{\pi}{4} = 2 \arctan \frac{1}{2} - \arctan \frac{1}{7}$$

$$\frac{\pi}{4} = 2 \arctan \frac{1}{3} + \arctan \frac{1}{7}$$

$$\frac{\pi}{4} = 5 \arctan \frac{1}{7} + 2 \arctan \frac{3}{79}$$

$$\frac{\pi}{4} = 12 \arctan \frac{1}{49} + 32 \arctan \frac{1}{57} - 5 \arctan \frac{1}{239} + 12 \arctan \frac{1}{110443}$$

$$\frac{\pi}{4} = 44 \arctan \frac{1}{57} + 7 \arctan \frac{1}{239} - 12 \arctan \frac{1}{682} + 24 \arctan \frac{1}{12943}$$

$$\frac{\pi}{4} = 183 \arctan \frac{1}{239} + 32 \arctan \frac{1}{1023} - 68 \arctan \frac{1}{5832} + 12 \arctan \frac{1}{110443} \\ - 12 \arctan \frac{1}{4841182} - 100 \arctan \frac{1}{6826318}$$

$$\frac{\pi}{4} = 183 \arctan \frac{1}{239} + 32 \arctan \frac{1}{1023} - 68 \arctan \frac{1}{5832} + 12 \arctan \frac{1}{113021} \\ - 100 \arctan \frac{1}{6826318} - 12 \arctan \frac{1}{33366019650} + 12 \arctan \frac{1}{43599522992503626068}$$

Identities:

$$\arctan x + \arctan y = \arctan \frac{x + y}{1 - xy} \text{ for } xy < 1,$$

$$\arctan x - \arctan y = \arctan \frac{x - y}{1 + xy} \text{ for } xy > -1,$$

$$\arctan \frac{a}{b} + \arctan \frac{c}{d} = \arctan \frac{ad + bc}{bd - ac} \frac{ac}{bd} < 1,$$

$$\arctan \frac{a}{b} - \arctan \frac{c}{d} = \arctan \frac{ad - bc}{bd + ac} \frac{ac}{bd} > -1.$$

9.20 SPHERICAL TRIANGLE IDENTITIES:

$$\frac{\sin\left(\frac{1}{2}(A - B)\right)}{\sin\left(\frac{1}{2}(A + B)\right)} = \frac{\tan\left(\frac{1}{2}(a - b)\right)}{\tan\left(\frac{1}{2}c\right)}$$

$$\frac{\sin\left(\frac{1}{2}(a - b)\right)}{\sin\left(\frac{1}{2}(a + b)\right)} = \frac{\tan\left(\frac{1}{2}(A - B)\right)}{\cot\left(\frac{1}{2}c\right)}$$

$$\frac{\cos\left(\frac{1}{2}(A - B)\right)}{\cos\left(\frac{1}{2}(A + B)\right)} = \frac{\tan\left(\frac{1}{2}(a + b)\right)}{\tan\left(\frac{1}{2}c\right)}$$

$$\frac{\cos\left(\frac{1}{2}(a - b)\right)}{\cos\left(\frac{1}{2}(a + b)\right)} = \frac{\tan\left(\frac{1}{2}(A + B)\right)}{\cot\left(\frac{1}{2}c\right)}$$

9.21 ABBREVIATIONS (9.1-9.19)

A=Angle 'A'

a=side 'a'
B=Angle 'B'
b=side 'b'
B=Angle 'B'
c=side 'c'

PART 10: EXPONENTIALS & LOGARITHMS

10.1 FUNDAMENTAL THEORY:

$$e^{\ln(x)} = x \quad \text{if } x > 0$$

$$\ln(e^x) = x.$$

$$\ln x = \int_1^x \frac{1}{t} dt$$

$$x = b^a \iff \log_b x = a$$

10.2 IDENTITIES:

$$\log_b(1) = 0$$

$$\log_b(b) = 1$$

$$\log_b(xy) = \log_b(x) + \log_b(y)$$

$$\log_b\left(\frac{x}{y}\right) = \log_b(x) - \log_b(y)$$

$$\log_b(x^d) = d \log_b(x)$$

$$\log_b(\sqrt[y]{x}) = \frac{\log_b(x)}{y}$$

$$x^{\log_b(y)} = y^{\log_b(x)}$$

$$c \log_b(x) + d \log_b(y) = \log_b(x^c y^d)$$

$$b^{\log_b(x)} = x \text{ because } \text{antilog}_b(\log_b(x)) = x$$

$$\log_b(b^x) = x \text{ because } \log_b(\text{antilog}_b(x)) = x$$

$$\log(\log(c^d)) = \log(\log(c)) + \log(d)$$

$$\log(\log(\sqrt[d]{c})) = \log(\log(c)) - \log(d)$$

$$\log_b(a + c) = \log_b a + \log_b \left(1 + \frac{c}{a}\right)$$

$$\log_b(a - c) = \log_b a + \log_b \left(1 - \frac{c}{a}\right)$$

$$x^{\frac{\log(\log(x))}{\log(x)}} = \log(x)$$

$$\int \log_a x dx = x(\log_a x - \log_a e) + C$$

$$\ln(a \times 10^n) = \ln a + n \ln 10.$$

10.3 CHANGE OF BASE:

$$\log_b x = \frac{\log_k x}{\log_k b}.$$

10.4 LAWS FOR LOG TABLES:

$$xy = b^{\log_b(x)} b^{\log_b(y)} = b^{\log_b(x) + \log_b(y)} \Rightarrow \log_b(xy) = \log_b(b^{\log_b(x) + \log_b(y)}) = \log_b(x) + \log_b(y)$$

$$x^y = (b^{\log_b(x)})^y = b^{y \log_b(x)} \Rightarrow \log_b(x^y) = y \log_b(x)$$

$$\log_b \left(\frac{x}{y} \right) = \log_b(xy^{-1}) = \log_b(x) + \log_b(y^{-1}) = \log_b(x) - \log_b(y)$$

$$\log_b(\sqrt[y]{x}) = \log_b(x^{\frac{1}{y}}) = \frac{1}{y} \log_b(x)$$

10.5 COMPLEX NUMBERS:

$$\log(z) = \ln |z| + i \arg(z) = \ln(r) + i(\theta + 2\pi k)$$

$$\text{Log}(z_1) + \text{Log}(z_2) = \text{Log}(z_1 z_2) \pmod{2\pi i}$$

$$\text{Log}(z_1) - \text{Log}(z_2) = \text{Log}(z_1/z_2) \pmod{2\pi i}$$

$$z_1^{z_2} = e^{z_2 \text{Log}(z_1)}$$

$$\text{Log}(z_1^{z_2}) = z_2 \text{Log}(z_1) \pmod{2\pi i}$$

10.6 LIMITS INVOLVING LOGARITHMIC TERMS

$$\lim_{x \rightarrow 0^+} \log_a x = -\infty \quad \text{if } a > 1$$

$$\lim_{x \rightarrow 0^+} \log_a x = \infty \quad \text{if } a < 1$$

$$\lim_{x \rightarrow \infty} \log_a x = \infty \quad \text{if } a > 1$$

$$\lim_{x \rightarrow \infty} \log_a x = -\infty \quad \text{if } a < 1$$

$$\lim_{x \rightarrow 0^+} x^b \log_a x = 0 \quad \text{if } b > 0$$

$$\lim_{x \rightarrow \infty} \frac{1}{x^b} \log_a x = 0 \quad \text{if } b > 0$$

PART 11: COMPLEX NUMBERS

11.1 GENERAL:

Fundamental: $i^2 = -1$

Standard Form: $z = a + bi$

Polar Form: $z = r \operatorname{cis} \theta = r(\cos \theta + i \sin \theta)$

Argument: $\arg(z) = \theta$, where $\tan \theta = \frac{b}{a}$

Modulus: $\operatorname{mod}(z) = r = |z| = |a + bi| = \sqrt{a^2 + b^2}$

Conjugate: $\bar{z} = a - bi$

Exponential: $z = r \cdot e^{i\theta}$

De Moivre's Formula:

$$z = r \operatorname{cis} \theta$$

$$z^n = r^n \operatorname{cis} \left(\frac{\theta + 2k\pi}{n} \right), \quad k=0, 1, \dots, (n-1)$$

Euler's Identity: $e^{i\pi} + 1 = 0$ (Special Case when $n=2$)

$$\sum_{k=0}^{n-1} e^{\frac{2i\pi k}{n}} = 0 \quad (\text{Generally})$$

11.2 OPERATIONS:

Addition: $(a + bi) + (c + di) = (a + c) + (b + d)i$

Subtraction: $(a + bi) - (c + di) = (a - c) + (b - d)i$

Multiplication: $(a + bi)(c + di) = ac + bci + adi + bdi^2 = (ac - bd) + (bc + ad)i$

Division:

$$\frac{(a + bi)}{(c + di)} = \frac{(a + bi)(c - di)}{(c + di)(c - di)} = \frac{ac + bci - adi + bd}{(c + di)(c - di)} = \left(\frac{ac + bd}{c^2 + d^2} \right) + \left(\frac{bc - ad}{c^2 + d^2} \right)i$$

Sum of Squares: $a^2 + b^2 = (a + bi)(a - bi)$

11.3 IDENTITIES:

Exponential: $e^{i\theta} = \cos(\theta) + i \sin(\theta)$

Logarithmic: $\log(x + iy) = \frac{1}{2} \ln(x^2 + y^2) + i \arg(x + iy)$,

Trigonometric: $\sin(x) = \frac{e^{ix} - e^{-ix}}{2i}$

$$\cos(x) = \frac{e^{ix} + e^{-ix}}{2}$$

$$\tan(x) = \frac{e^{ix} - e^{-ix}}{i(e^{ix} + e^{-ix})} = \frac{\sin(x)}{\cos(x)}$$

$$\sin(a + bi) = \sin(a) \cosh(b) + \cos(a) \sinh(b)i$$

Hyperbolic:

$$\cos(a + bi) = \cos(a)\cosh(b) - \sin(a)\sinh(b)i$$

$$e^{ix} = \cos x + i \sin x$$

$$e^{-ix} = \cos x - i \sin x$$

$$\cosh ix = \frac{1}{2}(e^{ix} + e^{-ix}) = \cos x$$

$$\sinh ix = \frac{1}{2}(e^{ix} - e^{-ix}) = i \sin x$$

$$\tanh ix = i \tan x$$

$$\cosh x = \cos ix$$

$$\sinh x = -i \sin ix$$

$$\tanh x = -i \tan ix$$

PART 12: DIFFERENTIATION

For Differential Equations, see Functions

12.1 GENERAL RULES:

Plus Or Minus:

$$y = f_{(x)} \pm g_{(x)} \pm h_{(x)} \dots$$

$$y' = f'_{(x)} \pm g'_{(x)} \pm h'_{(x)} \dots$$

Product Rule:

$$y = uv$$

$$y' = u'v + uv'$$

Quotient Rule:

$$y = \frac{u}{v}$$

$$y' = \frac{u'v - uv'}{v^2}$$

Power Rule:

$$y = (f_{(x)})^n$$

$$y' = n(f_{(x)})^{n-1} \times f'_{(x)}$$

Chain Rule:

$$\frac{dy}{dx} = \frac{dy}{du} \times \frac{du}{dv} \times \frac{dv}{dx}$$

Blob Rule:

$$y = e^{f_{(x)}}$$

$$y' = f'_{(x)} \times e^{f_{(x)}}$$

Base A Log:

$$y = \log_a f_{(x)}$$

$$y' = \frac{f'_{(x)}}{f_{(x)} \times \ln(a)}$$

Natural Log:

$$y = a \ln(f_{(x)})$$

$$y' = a \times \frac{f'_{(x)}}{f_{(x)}}$$

Exponential (X):

$$y = k^x$$

$$y' = \ln k \times k^x$$

First Principles:

$$f'_{(x)} = \lim_{h \rightarrow 0} \left(\frac{f_{(x+h)} - f_{(x)}}{h} \right)$$

12.2 EXPONENTIAL FUNCTIONS:

$$\frac{d}{dx}e^x = e^x.$$

$$\frac{d}{dx}a^x = (\ln a)a^x.$$

12.3 LOGARITHMIC FUNCTIONS:

$$\frac{d}{dx} \ln x = \frac{1}{x} = \frac{1}{x \ln e}, \quad x > 0$$

$$\frac{d}{dx} \log_b x = \frac{1}{x \ln b}, \quad b > 0, b \neq 1$$

$$\frac{d}{dx} \log_b(x) = \frac{\frac{d}{dx} \ln(x)}{\frac{d}{dx} \ln(b)} = \frac{1}{x \ln(b)} = \frac{\log_b(e)}{x}.$$

12.4 TRIGONOMETRIC FUNCTIONS:

$$(\sin(x))' = \cos(x)$$

$$(\cos(x))' = -\sin(x)$$

$$(\tan(x))' = \left(\frac{\sin(x)}{\cos(x)}\right)' = \frac{\cos^2(x) + \sin^2(x)}{\cos^2(x)} = \frac{1}{\cos^2(x)} = \sec^2(x)$$

$$(\cot(x))' = \left(\frac{\cos(x)}{\sin(x)}\right)' = \frac{-\sin^2(x) - \cos^2(x)}{\sin^2(x)} = -(1 + \cot^2(x)) = -\csc^2(x)$$

$$(\sec(x))' = \left(\frac{1}{\cos(x)}\right)' = \frac{\sin(x)}{\cos^2(x)} = \frac{1}{\cos(x)} \cdot \frac{\sin(x)}{\cos(x)} = \sec(x) \tan(x)$$

$$(\csc(x))' = \left(\frac{1}{\sin(x)}\right)' = -\frac{\cos(x)}{\sin^2(x)} = -\frac{1}{\sin(x)} \cdot \frac{\cos(x)}{\sin(x)} = -\csc(x) \cot(x)$$

$$(\arcsin(x))' = \frac{1}{\sqrt{1-x^2}}$$

$$(\arccos(x))' = \frac{-1}{\sqrt{1-x^2}}$$

$$(\arctan(x))' = \frac{1}{x^2 + 1}$$

12.5 HYPERBOLIC FUNCTIONS:

$$\frac{d}{dx} \sinh x = \cosh x$$

$$\frac{d}{dx} \cosh x = \sinh x$$

$$\frac{d}{dx} \tanh x = 1 - \tanh^2 x = \operatorname{sech}^2 x = 1/\cosh^2 x$$

$$\frac{d}{dx} \coth x = 1 - \coth^2 x = -\operatorname{csch}^2 x = -1/\sinh^2 x$$

$$\frac{d}{dx} \operatorname{csch} x = -\operatorname{coth} x \operatorname{csch} x$$

$$\frac{d}{dx} \operatorname{sech} x = -\tanh x \operatorname{sech} x$$

$$\frac{d}{dx} (\sinh^{-1} x) = \frac{1}{\sqrt{x^2 + 1}}$$

$$\frac{d}{dx} (\cosh^{-1} x) = \frac{1}{\sqrt{x^2 - 1}}$$

$$\frac{d}{dx} (\tanh^{-1} x) = \frac{1}{1 - x^2}$$

$$\frac{d}{dx} (\operatorname{csch}^{-1} x) = -\frac{1}{|x| \sqrt{1 + x^2}}$$

12.5 PARTIAL DIFFERENTIATION:

First Principles:

$$\frac{\partial f}{\partial x}(a, b) = \left. \frac{d(f(x, b))}{dx} \right|_{x=a} = \lim_{h \rightarrow 0} \frac{f(a + h, b) - f(a, b)}{h}$$

$$\frac{\partial f}{\partial y}(a, b) = \left. \frac{d(f(a, y))}{dy} \right|_{y=b} = \lim_{h \rightarrow 0} \frac{f(a, b + h) - f(a, b)}{h}$$

ie:

$$\frac{\partial f}{\partial x} = \lim_{h \rightarrow 0} \frac{f(x + h, y) - f(x, y)}{h}$$

$$\frac{\partial f}{\partial y} = \lim_{h \rightarrow 0} \frac{f(x, y + h) - f(x, y)}{h}$$

Gradient:

$$\nabla f = \left[\frac{\partial f}{\partial x}, \frac{\partial f}{\partial y}, \frac{\partial f}{\partial z} \right]$$

Total Differential:

$$df = f_x(x, y) dx + f_y(x, y) dy = \frac{\partial f}{\partial x} dx + \frac{\partial f}{\partial y} dy$$

Chain Rule:

Case 1. Suppose $F = F(u, v)$ and $u = u(x, y)$, $v = v(x, y)$. Then F is also a function of x and y and

$$\frac{\partial F}{\partial x} = \frac{\partial F}{\partial u} \frac{\partial u}{\partial x} + \frac{\partial F}{\partial v} \frac{\partial v}{\partial x}$$

$$\frac{\partial F}{\partial y} = \frac{\partial F}{\partial u} \frac{\partial u}{\partial y} + \frac{\partial F}{\partial v} \frac{\partial v}{\partial y}$$

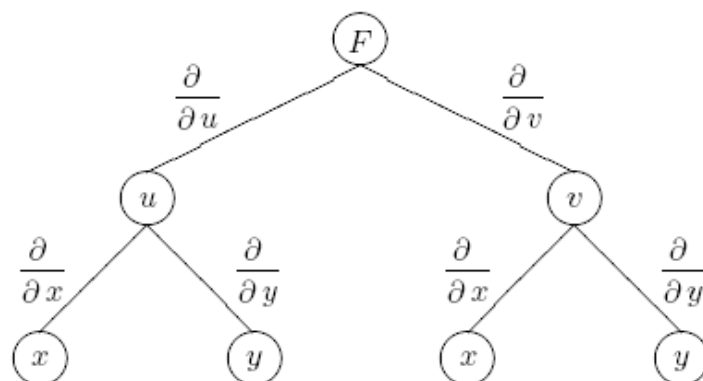

Case 2. Suppose $F = F(u, v)$ and $u = u(t)$, $v = v(t)$. Then F is a function of t only and

$$\frac{dF}{dt} = \frac{\partial F}{\partial u} \frac{du}{dt} + \frac{\partial F}{\partial v} \frac{dv}{dt}$$

(Note the 'full' derivative here)

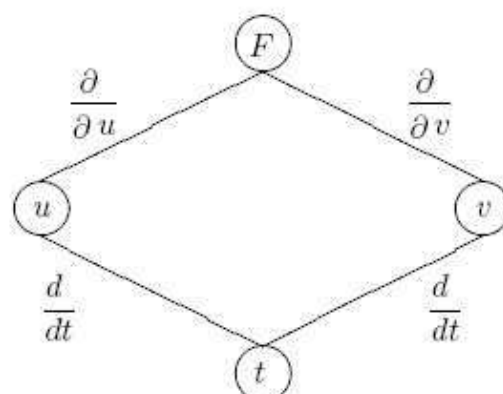

Case 3. $F = F(u)$, $u = u(x, y)$. Then F is a function of x and y and

$$\frac{\partial F}{\partial x} = \frac{dF}{du} \frac{\partial u}{\partial x}$$

$$\frac{\partial F}{\partial y} = \frac{dF}{du} \frac{\partial u}{\partial y}$$

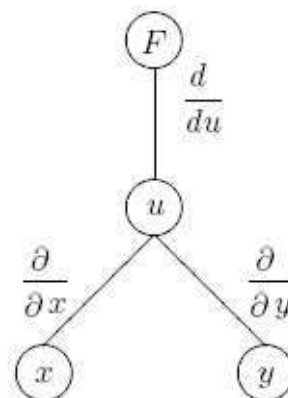

Implicit Differentiation:

Consider $z = F(x, y)$ where we assume the y is a function of x , i.e. $y = y(x)$. Then z is ultimately a function of x only and the chain rule tells us

$$\frac{dz}{dx} = \frac{\partial F}{\partial x} + \frac{\partial F}{\partial y} \frac{dy}{dx}.$$

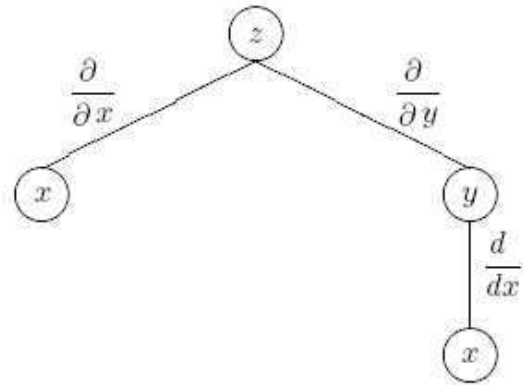

Therefore,

$$\boxed{\frac{dy}{dx} = -\frac{\partial F / \partial x}{\partial F / \partial y} = -\frac{F_x}{F_y}}$$

Higher Order Derivatives:

$$\frac{\partial}{\partial x} \left(\frac{\partial f}{\partial x} \right) \equiv \frac{\partial^2 f}{\partial x^2} \equiv f_{xx}$$

$$\frac{\partial}{\partial y} \left(\frac{\partial f}{\partial y} \right) \equiv \frac{\partial^2 f}{\partial y^2} \equiv f_{yy}$$

$$\frac{\partial}{\partial x} \left(\frac{\partial f}{\partial y} \right) \equiv \frac{\partial^2 f}{\partial x \partial y} \equiv f_{yx}$$

$$\frac{\partial}{\partial y} \left(\frac{\partial f}{\partial x} \right) \equiv \frac{\partial^2 f}{\partial y \partial x} \equiv f_{xy}$$

PART 13: INTEGRATION

13.1 GENERAL RULES:

Power Rule: $\int f'(x)[f(x)]^n dx = \frac{[f(x)]^{n+1}}{n+1} + C$

$$a \int f'(x)[f(x)]^n dx = a \frac{[f(x)]^{n+1}}{n+1} + C$$

By Parts: $\int u dv = uv - \int v du$

Constants: $\int_0^{f(x)} k dy = kf(x)$

13.2 RATIONAL FUNCTIONS:

$$\int (ax + b)^n dx = \frac{(ax + b)^{n+1}}{a(n+1)} + C \quad (\text{for } n \neq -1)$$

$$\int \frac{c}{ax + b} dx = \frac{c}{a} \ln |ax + b| + C$$

$$\int x(ax + b)^n dx = \frac{a(n+1)x - b}{a^2(n+1)(n+2)}(ax + b)^{n+1} + C \quad (\text{for } n \notin \{-1, -2\})$$

$$\int \frac{x}{ax + b} dx = \frac{x}{a} - \frac{b}{a^2} \ln |ax + b| + C$$

$$\int \frac{x}{(ax + b)^2} dx = \frac{b}{a^2(ax + b)} + \frac{1}{a^2} \ln |ax + b| + C$$

$$\int \frac{x}{(ax + b)^n} dx = \frac{x}{a^2(n-1)(n-2)(ax + b)^{n-1}} + C \quad (\text{for } n \notin \{1, 2\})$$

$$\int \frac{x^2}{ax + b} dx = \frac{b^2 \ln |ax + b|}{a^3} + \frac{ax^2 - 2bx}{2a^2} + C$$

$$\int \frac{x^2}{(ax + b)^2} dx = \frac{1}{a^3} \left(ax - 2b \ln |ax + b| - \frac{b^2}{ax + b} \right) + C$$

$$\int \frac{x^2}{(ax + b)^3} dx = \frac{1}{a^3} \left(\ln |ax + b| + \frac{2b}{ax + b} - \frac{b^2}{2(ax + b)^2} \right) + C$$

$$\int \frac{x^2}{(ax + b)^n} dx = \frac{1}{a^3} \left(-\frac{(ax + b)^{3-n}}{(n-3)} + \frac{2b(ax + b)^{2-n}}{(n-2)} - \frac{b^2(ax + b)^{1-n}}{(n-1)} \right) + C \quad (\text{for } n \notin \{1, 2, 3\})$$

$$\int \frac{1}{x(ax + b)} dx = -\frac{1}{b} \ln \left| \frac{ax + b}{x} \right| + C$$

$$\int \frac{1}{x^2(ax + b)} dx = -\frac{1}{bx} + \frac{a}{b^2} \ln \left| \frac{ax + b}{x} \right| + C$$

$$\int \frac{1}{x^2(ax + b)^2} dx = -a \left(\frac{1}{b^2(ax + b)} + \frac{1}{ab^2x} - \frac{2}{b^3} \ln \left| \frac{ax + b}{x} \right| \right) + C$$

$$\int \frac{1}{x^2 + a^2} dx = \frac{1}{a} \arctan \frac{x}{a} + C$$

$$\int \frac{1}{x^2 - a^2} dx = \begin{cases} -\frac{1}{a} \operatorname{arctanh} \frac{x}{a} = \frac{1}{2a} \ln \frac{a-x}{a+x} + C & (\text{for } |x| < |a|) \\ -\frac{1}{a} \operatorname{arccoth} \frac{x}{a} = \frac{1}{2a} \ln \frac{x-a}{x+a} + C & (\text{for } |x| > |a|) \end{cases}$$

For $a \neq 0$:

$$\int \frac{1}{ax^2 + bx + c} dx = \begin{cases} \frac{2}{\sqrt{4ac-b^2}} \arctan \frac{2ax+b}{\sqrt{4ac-b^2}} + C & (\text{for } 4ac - b^2 > 0) \\ -\frac{2}{\sqrt{b^2-4ac}} \operatorname{arctanh} \frac{2ax+b}{\sqrt{b^2-4ac}} + C = \frac{1}{\sqrt{b^2-4ac}} \ln \left| \frac{2ax+b-\sqrt{b^2-4ac}}{2ax+b+\sqrt{b^2-4ac}} \right| + C & (\text{for } 4ac - b^2 < 0) \\ -\frac{2}{2ax+b} + C & (\text{for } 4ac - b^2 = 0) \end{cases}$$

$$\int \frac{x}{ax^2 + bx + c} dx = \frac{1}{2a} \ln |ax^2 + bx + c| - \frac{b}{2a} \int \frac{dx}{ax^2 + bx + c} + C$$

$$\int \frac{mx + n}{ax^2 + bx + c} dx = \begin{cases} \frac{m}{2a} \ln |ax^2 + bx + c| + \frac{2an-bm}{a\sqrt{4ac-b^2}} \arctan \frac{2ax+b}{\sqrt{4ac-b^2}} + C & (\text{for } 4ac - b^2 > 0) \\ \frac{m}{2a} \ln |ax^2 + bx + c| - \frac{2an-bm}{a\sqrt{b^2-4ac}} \operatorname{arctanh} \frac{2ax+b}{\sqrt{b^2-4ac}} + C & (\text{for } 4ac - b^2 < 0) \\ \frac{m}{2a} \ln |ax^2 + bx + c| - \frac{2an-bm}{a(2ax+b)} + C & (\text{for } 4ac - b^2 = 0) \end{cases}$$

$$\int \frac{1}{(ax^2 + bx + c)^n} dx = \frac{2ax + b}{(n-1)(4ac-b^2)(ax^2 + bx + c)^{n-1}} + \frac{(2n-3)2a}{(n-1)(4ac-b^2)} \int \frac{1}{(ax^2 + bx + c)^{n-1}} dx + C$$

$$\int \frac{x}{(ax^2 + bx + c)^n} dx = -\frac{bx + 2c}{(n-1)(4ac-b^2)(ax^2 + bx + c)^{n-1}} - \frac{b(2n-3)}{(n-1)(4ac-b^2)} \int \frac{1}{(ax^2 + bx + c)^{n-1}} dx + C$$

$$\int \frac{1}{x(ax^2 + bx + c)} dx = \frac{1}{2c} \ln \left| \frac{x^2}{ax^2 + bx + c} \right| - \frac{b}{2c} \int \frac{1}{ax^2 + bx + c} dx + C$$

$$\int \frac{dx}{x^{2n} + 1} = \sum_{k=1}^{2^{n-1}} \left\{ \frac{1}{2^{n-1}} \left[\sin \left(\frac{(2k-1)\pi}{2^n} \right) \arctan \left[\left(x - \cos \left(\frac{(2k-1)\pi}{2^n} \right) \right) \csc \left(\frac{(2k-1)\pi}{2^n} \right) \right] - \frac{1}{2^n} \left[\cos \left(\frac{(2k-1)\pi}{2^n} \right) \ln \left| x^2 - 2x \cos \left(\frac{(2k-1)\pi}{2^n} \right) + 1 \right| \right] \right\}$$

13.3 TRIGONOMETRIC FUNCTIONS (SINE):

$$\int \sin ax \, dx = -\frac{1}{a} \cos ax + C$$

$$\int \sin^2 ax \, dx = \frac{x}{2} - \frac{1}{4a} \sin 2ax + C = \frac{x}{2} - \frac{1}{2a} \sin ax \cos ax + C$$

$$\int x \sin^2 ax \, dx = \frac{x^2}{4} - \frac{x}{4a} \sin 2ax - \frac{1}{8a^2} \cos 2ax + C$$

$$\int x^2 \sin^2 ax \, dx = \frac{x^3}{6} - \left(\frac{x^2}{4a} - \frac{1}{8a^3} \right) \sin 2ax - \frac{x}{4a^2} \cos 2ax + C$$

$$\int \sin b_1 x \sin b_2 x \, dx = \frac{\sin((b_1 - b_2)x)}{2(b_1 - b_2)} - \frac{\sin((b_1 + b_2)x)}{2(b_1 + b_2)} + C \quad (\text{for } |b_1| \neq |b_2|)$$

$$\int \sin^n ax \, dx = -\frac{\sin^{n-1} ax \cos ax}{na} + \frac{n-1}{n} \int \sin^{n-2} ax \, dx \quad (\text{for } n > 0)$$

$$\int \frac{dx}{\sin ax} = \frac{1}{a} \ln \left| \tan \frac{ax}{2} \right| + C$$

$$\int \frac{dx}{\sin^n ax} = \frac{\cos ax}{a(1-n)\sin^{n-1} ax} + \frac{n-2}{n-1} \int \frac{dx}{\sin^{n-2} ax} \quad (\text{for } n > 1)$$

$$\int x \sin ax \, dx = \frac{\sin ax}{a^2} - \frac{x \cos ax}{a} + C$$

$$\int x^n \sin ax \, dx = -\frac{x^n}{a} \cos ax + \frac{n}{a} \int x^{n-1} \cos ax \, dx \quad (\text{for } n > 0)$$

$$\int_{-\frac{\pi}{2}}^{\frac{\pi}{2}} x^2 \sin^2 \frac{n\pi x}{a} \, dx = \frac{a^3(n^2\pi^2 - 6)}{24n^2\pi^2} \quad (\text{for } n = 2, 4, 6\dots)$$

$$\int \frac{\sin ax}{x} dx = \sum_{n=0}^{\infty} (-1)^n \frac{(ax)^{2n+1}}{(2n+1) \cdot (2n+1)!} + C$$

$$\int \frac{\sin ax}{x^n} dx = -\frac{\sin ax}{(n-1)x^{n-1}} + \frac{a}{n-1} \int \frac{\cos ax}{x^{n-1}} dx$$

$$\int \frac{dx}{1 \pm \sin ax} = \frac{1}{a} \tan \left(\frac{ax}{2} \mp \frac{\pi}{4} \right) + C$$

$$\int \frac{x \, dx}{1 + \sin ax} = \frac{x}{a} \tan \left(\frac{ax}{2} - \frac{\pi}{4} \right) + \frac{2}{a^2} \ln \left| \cos \left(\frac{ax}{2} - \frac{\pi}{4} \right) \right| + C$$

$$\int \frac{x \, dx}{1 - \sin ax} = \frac{x}{a} \cot \left(\frac{\pi}{4} - \frac{ax}{2} \right) + \frac{2}{a^2} \ln \left| \sin \left(\frac{\pi}{4} - \frac{ax}{2} \right) \right| + C$$

$$\int \frac{\sin ax \, dx}{1 \pm \sin ax} = \pm x + \frac{1}{a} \tan \left(\frac{\pi}{4} \mp \frac{ax}{2} \right) + C$$

13.4 TRIGONOMETRIC FUNCTIONS (COSINE):

$$\int \cos ax \, dx = \frac{1}{a} \sin ax + C$$

$$\int \cos^2 ax \, dx = \frac{x}{2} + \frac{1}{4a} \sin 2ax + C = \frac{x}{2} + \frac{1}{2a} \sin ax \cos ax + C$$

$$\int \cos^n ax \, dx = \frac{\cos^{n-1} ax \sin ax}{na} + \frac{n-1}{n} \int \cos^{n-2} ax \, dx \quad (\text{for } n > 0)$$

$$\int x \cos ax \, dx = \frac{\cos ax}{a^2} + \frac{x \sin ax}{a} + C$$

$$\int x^2 \cos^2 ax \, dx = \frac{x^3}{6} + \left(\frac{x^2}{4a} - \frac{1}{8a^3} \right) \sin 2ax + \frac{x}{4a^2} \cos 2ax + C$$

$$\int x^n \cos ax \, dx = \frac{x^n \sin ax}{a} - \frac{n}{a} \int x^{n-1} \sin ax \, dx$$

$$\int \frac{\cos ax}{x} dx = \ln |ax| + \sum_{k=1}^{\infty} (-1)^k \frac{(ax)^{2k}}{2k \cdot (2k)!} + C$$

$$\int \frac{\cos ax}{x^n} dx = -\frac{\cos ax}{(n-1)x^{n-1}} - \frac{a}{n-1} \int \frac{\sin ax}{x^{n-1}} dx \quad (\text{for } n \neq 1)$$

$$\int \frac{dx}{\cos ax} = \frac{1}{a} \ln \left| \tan \left(\frac{ax}{2} + \frac{\pi}{4} \right) \right| + C$$

$$\int \frac{dx}{\cos^n ax} = \frac{\sin ax}{a(n-1)\cos^{n-1} ax} + \frac{n-2}{n-1} \int \frac{dx}{\cos^{n-2} ax} \quad (\text{for } n > 1)$$

$$\int \frac{dx}{1 + \cos ax} = \frac{1}{a} \tan \frac{ax}{2} + C$$

$$\int \frac{dx}{1 - \cos ax} = -\frac{1}{a} \cot \frac{ax}{2} + C$$

$$\int \frac{x dx}{1 + \cos ax} = \frac{x}{a} \tan \frac{ax}{2} + \frac{2}{a^2} \ln \left| \cos \frac{ax}{2} \right| + C$$

$$\int \frac{x dx}{1 - \cos ax} = -\frac{x}{a} \cot \frac{ax}{2} + \frac{2}{a^2} \ln \left| \sin \frac{ax}{2} \right| + C$$

$$\int \frac{\cos ax dx}{1 + \cos ax} = x - \frac{1}{a} \tan \frac{ax}{2} + C$$

$$\int \frac{\cos ax dx}{1 - \cos ax} = -x - \frac{1}{a} \cot \frac{ax}{2} + C$$

$$\int \cos a_1 x \cos a_2 x dx = \frac{\sin(a_1 - a_2)x}{2(a_1 - a_2)} + \frac{\sin(a_1 + a_2)x}{2(a_1 + a_2)} + C \quad (\text{for } |a_1| \neq |a_2|)$$

13.5 TRIGONOMETRIC FUNCTIONS (TANGENT):

$$\int \tan ax dx = -\frac{1}{a} \ln |\cos ax| + C = \frac{1}{a} \ln |\sec ax| + C$$

$$\int \tan^n ax dx = \frac{1}{a(n-1)} \tan^{n-1} ax - \int \tan^{n-2} ax dx \quad (\text{for } n \neq 1)$$

$$\int \frac{dx}{q \tan ax + p} = \frac{1}{p^2 + q^2} \left(px + \frac{q}{a} \ln |q \sin ax + p \cos ax| \right) + C \quad (\text{for } p^2 + q^2 \neq 0)$$

$$\int \frac{dx}{\tan ax} = \frac{1}{a} \ln |\sin ax| + C$$

$$\int \frac{dx}{\tan ax + 1} = \frac{x}{2} + \frac{1}{2a} \ln |\sin ax + \cos ax| + C$$

$$\int \frac{dx}{\tan ax - 1} = -\frac{x}{2} + \frac{1}{2a} \ln |\sin ax - \cos ax| + C$$

$$\int \frac{\tan ax dx}{\tan ax + 1} = \frac{x}{2} - \frac{1}{2a} \ln |\sin ax + \cos ax| + C$$

$$\int \frac{\tan ax dx}{\tan ax - 1} = \frac{x}{2} + \frac{1}{2a} \ln |\sin ax - \cos ax| + C$$

13.6 TRIGONOMETRIC FUNCTIONS (SECANT):

$$\int \sec ax \, dx = \frac{1}{a} \ln |\sec ax + \tan ax| + C$$

$$\int \sec^2 x \, dx = \tan x + C$$

$$\int \sec^n ax \, dx = \frac{\sec^{n-1} ax \sin ax}{a(n-1)} + \frac{n-2}{n-1} \int \sec^{n-2} ax \, dx \quad (\text{for } n \neq 1)$$

$$\int \sec^n x \, dx = \frac{\sec^{n-2} x \tan x}{n-1} + \frac{n-2}{n-1} \int \sec^{n-2} x \, dx$$

$$\int \frac{dx}{\sec x + 1} = x - \tan \frac{x}{2} + C$$

$$\int \frac{dx}{\sec x - 1} = -x - \cot \frac{x}{2} + C$$

13.7 TRIGONOMETRIC FUNCTIONS (COTANGENT):

$$\int \cot ax \, dx = \frac{1}{a} \ln |\sin ax| + C$$

$$\int \cot^n ax \, dx = -\frac{1}{a(n-1)} \cot^{n-1} ax - \int \cot^{n-2} ax \, dx \quad (\text{for } n \neq 1)$$

$$\int \frac{dx}{1 + \cot ax} = \int \frac{\tan ax \, dx}{\tan ax + 1}$$

$$\int \frac{dx}{1 - \cot ax} = \int \frac{\tan ax \, dx}{\tan ax - 1}$$

13.8 TRIGONOMETRIC FUNCTIONS (SINE & COSINE):

$$\int \frac{dx}{\cos ax \pm \sin ax} = \frac{1}{a\sqrt{2}} \ln \left| \tan \left(\frac{ax}{2} \pm \frac{\pi}{8} \right) \right| + C$$

$$\int \frac{dx}{(\cos ax \pm \sin ax)^2} = \frac{1}{2a} \tan \left(ax \mp \frac{\pi}{4} \right) + C$$

$$\int \frac{dx}{(\cos x + \sin x)^n} = \frac{1}{n-1} \left(\frac{\sin x - \cos x}{(\cos x + \sin x)^{n-1}} - 2(n-2) \int \frac{dx}{(\cos x + \sin x)^{n-2}} \right)$$

$$\int \frac{\cos ax \, dx}{\cos ax + \sin ax} = \frac{x}{2} + \frac{1}{2a} \ln |\sin ax + \cos ax| + C$$

$$\int \frac{\cos ax \, dx}{\cos ax - \sin ax} = \frac{x}{2} - \frac{1}{2a} \ln |\sin ax - \cos ax| + C$$

$$\int \frac{\sin ax \, dx}{\cos ax + \sin ax} = \frac{x}{2} - \frac{1}{2a} \ln |\sin ax + \cos ax| + C$$

$$\int \frac{\sin ax \, dx}{\cos ax - \sin ax} = -\frac{x}{2} - \frac{1}{2a} \ln |\sin ax - \cos ax| + C$$

$$\int \frac{\cos ax \, dx}{\sin ax(1 + \cos ax)} = -\frac{1}{4a} \tan^2 \frac{ax}{2} + \frac{1}{2a} \ln \left| \tan \frac{ax}{2} \right| + C$$

$$\int \frac{\cos ax \, dx}{\sin ax(1 - \cos ax)} = -\frac{1}{4a} \cot^2 \frac{ax}{2} - \frac{1}{2a} \ln \left| \tan \frac{ax}{2} \right| + C$$

$$\int \frac{\sin ax \, dx}{\cos ax(1 + \sin ax)} = \frac{1}{4a} \cot^2 \left(\frac{ax}{2} + \frac{\pi}{4} \right) + \frac{1}{2a} \ln \left| \tan \left(\frac{ax}{2} + \frac{\pi}{4} \right) \right| + C$$

$$\int \frac{\sin ax \, dx}{\cos ax(1 - \sin ax)} = \frac{1}{4a} \tan^2 \left(\frac{ax}{2} + \frac{\pi}{4} \right) - \frac{1}{2a} \ln \left| \tan \left(\frac{ax}{2} + \frac{\pi}{4} \right) \right| + C$$

$$\int \sin ax \cos ax \, dx = -\frac{1}{2a} \cos^2 ax + C$$

$$\int \sin a_1 x \cos a_2 x \, dx = -\frac{\cos((a_1 - a_2)x)}{2(a_1 - a_2)} - \frac{\cos((a_1 + a_2)x)}{2(a_1 + a_2)} + C \quad (\text{for } |a_1| \neq |a_2|)$$

$$\int \sin^n ax \cos ax \, dx = \frac{1}{a(n+1)} \sin^{n+1} ax + C \quad (\text{for } n \neq -1)$$

$$\int \sin ax \cos^n ax \, dx = -\frac{1}{a(n+1)} \cos^{n+1} ax + C \quad (\text{for } n \neq -1)$$

$$\int \sin^n ax \cos^m ax \, dx = -\frac{\sin^{n-1} ax \cos^{m+1} ax}{a(n+m)} + \frac{n-1}{n+m} \int \sin^{n-2} ax \cos^m ax \, dx \quad (f$$

also:

$$\int \sin^n ax \cos^m ax \, dx = \frac{\sin^{n+1} ax \cos^{m-1} ax}{a(n+m)} + \frac{m-1}{n+m} \int \sin^n ax \cos^{m-2} ax \, dx \quad (\text{for$$

$$\int \frac{dx}{\sin ax \cos ax} = \frac{1}{a} \ln |\tan ax| + C$$

$$\int \frac{dx}{\sin ax \cos^n ax} = \frac{1}{a(n-1) \cos^{n-1} ax} + \int \frac{dx}{\sin ax \cos^{n-2} ax} \quad (\text{for } n \neq 1)$$

$$\int \frac{dx}{\sin^n ax \cos ax} = -\frac{1}{a(n-1) \sin^{n-1} ax} + \int \frac{dx}{\sin^{n-2} ax \cos ax} \quad (\text{for } n \neq 1)$$

$$\int \frac{\sin ax \, dx}{\cos^n ax} = \frac{1}{a(n-1) \cos^{n-1} ax} + C \quad (\text{for } n \neq 1)$$

$$\int \frac{\sin^2 ax \, dx}{\cos ax} = -\frac{1}{a} \sin ax + \frac{1}{a} \ln \left| \tan \left(\frac{\pi}{4} + \frac{ax}{2} \right) \right| + C$$

$$\int \frac{\sin^2 ax \, dx}{\cos^n ax} = \frac{\sin ax}{a(n-1) \cos^{n-1} ax} - \frac{1}{n-1} \int \frac{dx}{\cos^{n-2} ax} \quad (\text{for } n \neq 1)$$

$$\int \frac{\sin^n ax \, dx}{\cos ax} = -\frac{\sin^{n-1} ax}{a(n-1)} + \int \frac{\sin^{n-2} ax \, dx}{\cos ax} \quad (\text{for } n \neq 1)$$

$$\int \frac{\sin^n ax \, dx}{\cos^m ax} = \frac{\sin^{n+1} ax}{a(m-1) \cos^{m-1} ax} - \frac{n-m+2}{m-1} \int \frac{\sin^n ax \, dx}{\cos^{m-2} ax} \quad (\text{for } m \neq 1)$$

also:

$$\int \frac{\sin^n ax \, dx}{\cos^m ax} = -\frac{\sin^{n-1} ax}{a(n-m) \cos^{m-1} ax} + \frac{n-1}{n-m} \int \frac{\sin^{n-2} ax \, dx}{\cos^m ax} \quad (\text{for } m \neq n)$$

also:

$$\int \frac{\sin^n ax \, dx}{\cos^m ax} = \frac{\sin^{n-1} ax}{a(m-1) \cos^{m-1} ax} - \frac{n-1}{m-1} \int \frac{\sin^{n-2} ax \, dx}{\cos^{m-2} ax} \quad (\text{for } m \neq 1)$$

$$\int \frac{\cos ax \, dx}{\sin^n ax} = -\frac{1}{a(n-1)\sin^{n-1} ax} + C \quad (\text{for } n \neq 1)$$

$$\int \frac{\cos^2 ax \, dx}{\sin ax} = \frac{1}{a} \left(\cos ax + \ln \left| \tan \frac{ax}{2} \right| \right) + C$$

$$\int \frac{\cos^2 ax \, dx}{\sin^n ax} = -\frac{1}{n-1} \left(\frac{\cos ax}{a \sin^{n-1} ax} + \int \frac{dx}{\sin^{n-2} ax} \right) \quad (\text{for } n \neq 1)$$

$$\int \frac{\cos^n ax \, dx}{\sin^m ax} = -\frac{\cos^{n+1} ax}{a(m-1)\sin^{m-1} ax} - \frac{n-m-2}{m-1} \int \frac{\cos^n ax \, dx}{\sin^{m-2} ax} \quad (\text{for } m \neq 1)$$

also:

$$\int \frac{\cos^n ax \, dx}{\sin^m ax} = \frac{\cos^{n-1} ax}{a(n-m)\sin^{m-1} ax} + \frac{n-1}{n-m} \int \frac{\cos^{n-2} ax \, dx}{\sin^m ax} \quad (\text{for } m \neq n)$$

also:

$$\int \frac{\cos^n ax \, dx}{\sin^m ax} = -\frac{\cos^{n-1} ax}{a(m-1)\sin^{m-1} ax} - \frac{n-1}{m-1} \int \frac{\cos^{n-2} ax \, dx}{\sin^{m-2} ax} \quad (\text{for } m \neq 1)$$

13.9 TRIGONOMETRIC FUNCTIONS (SINE & TANGENT):

$$\int \sin ax \tan ax \, dx = \frac{1}{a} (\ln |\sec ax + \tan ax| - \sin ax) + C$$

$$\int \frac{\tan^n ax \, dx}{\sin^2 ax} = \frac{1}{a(n-1)} \tan^{n-1}(ax) + C \quad (\text{for } n \neq 1)$$

13.10 TRIGONOMETRIC FUNCTIONS (COSINE & TANGENT):

$$\int \frac{\tan^n ax \, dx}{\cos^2 ax} = \frac{1}{a(n+1)} \tan^{n+1} ax + C \quad (\text{for } n \neq -1)$$

13.11 TRIGONOMETRIC FUNCTIONS (SINE & COTANGENT):

$$\int \frac{\cot^n ax \, dx}{\sin^2 ax} = \frac{1}{a(n+1)} \cot^{n+1} ax + C \quad (\text{for } n \neq -1)$$

13.12 TRIGONOMETRIC FUNCTIONS (COSINE & COTANGENT):

$$\int \frac{\cot^n ax \, dx}{\cos^2 ax} = \frac{1}{a(1-n)} \tan^{1-n} ax + C \quad (\text{for } n \neq 1)$$

13.13 TRIGONOMETRIC FUNCTIONS (ARCSINE):

$$\int \arcsin x \, dx = x \arcsin x + \sqrt{1-x^2} + C$$

$$\int \arcsin \frac{x}{a} \, dx = x \arcsin \frac{x}{a} + \sqrt{a^2-x^2} + C$$

$$\int x \arcsin \frac{x}{a} dx = \left(\frac{x^2}{2} - \frac{a^2}{4} \right) \arcsin \frac{x}{a} + \frac{x}{4} \sqrt{a^2 - x^2} + C$$

$$\int x^2 \arcsin \frac{x}{a} dx = \frac{x^3}{3} \arcsin \frac{x}{a} + \frac{x^2 + 2a^2}{9} \sqrt{a^2 - x^2} + C$$

$$\int x^n \arcsin x dx = \frac{1}{n+1} \left(x^{n+1} \arcsin x + \frac{x^n \sqrt{1-x^2} - nx^{n-1} \arcsin x}{n-1} + n \int x^{n-2} \arcsin x dx \right)$$

$$\int \cos^n x \arcsin x dx = \left(x^{n^2+1} \arccos x + \frac{x^n \sqrt{1-x^4} - nx^{n^2-1} \arccos x}{n^2-1} + n \int x^{n^2-2} \arccos x dx \right)$$

13.14 TRIGONOMETRIC FUNCTIONS (ARCCOSINE):

$$\int \arccos x dx = x \arccos x - \sqrt{1-x^2} + C$$

$$\int \arccos \frac{x}{a} dx = x \arccos \frac{x}{a} - \sqrt{a^2 - x^2} + C$$

$$\int x \arccos \frac{x}{a} dx = \left(\frac{x^2}{2} - \frac{a^2}{4} \right) \arccos \frac{x}{a} - \frac{x}{4} \sqrt{a^2 - x^2} + C$$

$$\int x^2 \arccos \frac{x}{a} dx = \frac{x^3}{3} \arccos \frac{x}{a} - \frac{x^2 + 2a^2}{9} \sqrt{a^2 - x^2} + C$$

13.15 TRIGONOMETRIC FUNCTIONS (ARCTANGENT):

$$\int \arctan x dx = x \arctan x - \frac{1}{2} \ln(1+x^2) + C$$

$$\int \arctan \left(\frac{x}{a} \right) dx = x \arctan \left(\frac{x}{a} \right) - \frac{a}{2} \ln \left(1 + \frac{x^2}{a^2} \right) + C$$

$$\int x \arctan \left(\frac{x}{a} \right) dx = \frac{(a^2 + x^2) \arctan \left(\frac{x}{a} \right) - ax}{2} + C$$

$$\int x^2 \arctan \left(\frac{x}{a} \right) dx = \frac{x^3}{3} \arctan \left(\frac{x}{a} \right) - \frac{ax^2}{6} + \frac{a^3}{6} \ln(a^2 + x^2) + C$$

$$\int x^n \arctan \left(\frac{x}{a} \right) dx = \frac{x^{n+1}}{n+1} \arctan \left(\frac{x}{a} \right) - \frac{a}{n+1} \int \frac{x^{n+1}}{a^2 + x^2} dx, \quad n \neq -1$$

13.16 TRIGONOMETRIC FUNCTIONS (ARCCOSECANT):

$$\int \operatorname{arccsc} x dx = x \operatorname{arccsc} x + \ln \left| x + x \sqrt{\frac{x^2-1}{x^2}} \right| + C$$

$$\int \operatorname{arccsc} \frac{x}{a} dx = x \operatorname{arccsc} \frac{x}{a} + a \ln \left(\frac{x}{a} \left(\sqrt{1 - \frac{a^2}{x^2}} + 1 \right) \right) + C$$

$$\int x \operatorname{arccsc} \frac{x}{a} dx = \frac{x^2}{2} \operatorname{arccsc} \frac{x}{a} + \frac{ax}{2} \sqrt{1 - \frac{a^2}{x^2}} + C$$

13.17 TRIGONOMETRIC FUNCTIONS (ARCSECANT):

$$\int \operatorname{arcsec} x dx = x \operatorname{arcsec} x - \ln \left| x + x \sqrt{\frac{x^2 - 1}{x^2}} \right| + C$$

$$\int \operatorname{arcsec} \frac{x}{a} dx = x \operatorname{arcsec} \frac{x}{a} + \frac{x}{a|x|} \ln \left| x \pm \sqrt{x^2 - 1} \right| + C$$

$$\int x \operatorname{arcsec} x dx = \frac{1}{2} \left(x^2 \operatorname{arcsec} x - \sqrt{x^2 - 1} \right) + C$$

$$\int x^n \operatorname{arcsec} x dx = \frac{1}{n+1} \left(x^{n+1} \operatorname{arcsec} x - \frac{1}{n} \left[x^{n-1} \sqrt{x^2 - 1} + [1-n] \left(x^{n-1} \operatorname{arcsec} x + (1-n) \int x^{n-2} \operatorname{arcsec} x dx \right) \right] \right)$$

13.18 TRIGONOMETRIC FUNCTIONS (ARCCOTANGENT):

$$\int \operatorname{arccot} x dx = x \operatorname{arccot} x + \frac{1}{2} \ln(1 + x^2) + C$$

$$\int \operatorname{arccot} \frac{x}{a} dx = x \operatorname{arccot} \frac{x}{a} + \frac{a}{2} \ln(a^2 + x^2) + C$$

$$\int x \operatorname{arccot} \frac{x}{a} dx = \frac{a^2 + x^2}{2} \operatorname{arccot} \frac{x}{a} + \frac{ax}{2} + C$$

$$\int x^2 \operatorname{arccot} \frac{x}{a} dx = \frac{x^3}{3} \operatorname{arccot} \frac{x}{a} + \frac{ax^2}{6} - \frac{a^3}{6} \ln(a^2 + x^2) + C$$

$$\int x^n \operatorname{arccot} \frac{x}{a} dx = \frac{x^{n+1}}{n+1} \operatorname{arccot} \frac{x}{a} + \frac{a}{n+1} \int \frac{x^{n+1}}{a^2 + x^2} dx, \quad n \neq -1$$

13.19 EXPONENTIAL FUNCTIONS

$$\int e^x dx = e^x$$

$$\int e^{cx} dx = \frac{1}{c} e^{cx}$$

$$\int a^{cx} dx = \frac{1}{c \cdot \ln a} a^{cx} \quad \text{for } a > 0, a \neq 1$$

$$\int x e^{cx} dx = \frac{e^{cx}}{c^2} (cx - 1)$$

$$\int x^2 e^{cx} dx = e^{cx} \left(\frac{x^2}{c} - \frac{2x}{c^2} + \frac{2}{c^3} \right)$$

$$\int x^n e^{cx} dx = \frac{1}{c} x^n e^{cx} - \frac{n}{c} \int x^{n-1} e^{cx} dx$$

$$\int \frac{e^{cx}}{x} dx = \ln|x| + \sum_{n=1}^{\infty} \frac{(cx)^n}{n \cdot n!}$$

$$\int \frac{e^{cx}}{x^n} dx = \frac{1}{n-1} \left(-\frac{e^{cx}}{x^{n-1}} + c \int \frac{e^{cx}}{x^{n-1}} dx \right) \quad (\text{for } n \neq 1)$$

$$\int e^{cx} \ln x dx = \frac{1}{c} e^{cx} \ln|x| - \text{Ei}(cx)$$

$$\int e^{cx} \sin bx dx = \frac{e^{cx}}{c^2 + b^2} (c \sin bx - b \cos bx)$$

$$\int e^{cx} \cos bx dx = \frac{e^{cx}}{c^2 + b^2} (c \cos bx + b \sin bx)$$

$$\int e^{cx} \sin^n x dx = \frac{e^{cx} \sin^{n-1} x}{c^2 + n^2} (c \sin x - n \cos x) + \frac{n(n-1)}{c^2 + n^2} \int e^{cx} \sin^{n-2} x dx$$

$$\int e^{cx} \cos^n x dx = \frac{e^{cx} \cos^{n-1} x}{c^2 + n^2} (c \cos x + n \sin x) + \frac{n(n-1)}{c^2 + n^2} \int e^{cx} \cos^{n-2} x dx$$

$$\int x e^{cx^2} dx = \frac{1}{2c} e^{cx^2}$$

$$\int e^{-cx^2} dx = \sqrt{\frac{\pi}{4c}} \text{erf}(\sqrt{cx}) \quad (\text{erf is the Error function})$$

$$\int x e^{-cx^2} dx = -\frac{1}{2c} e^{-cx^2}$$

$$\int \frac{1}{\sigma\sqrt{2\pi}} e^{-(x-\mu)^2/2\sigma^2} dx = \frac{1}{2} \left(1 + \text{erf} \frac{x-\mu}{\sigma\sqrt{2}} \right)$$

$$\int e^{x^2} dx = e^{x^2} \left(\sum_{j=0}^{n-1} c_{2j} \frac{1}{x^{2j+1}} \right) + (2n-1)c_{2n-2} \int \frac{e^{x^2}}{x^{2n}} dx \quad \text{valid for } n > 0,$$

$$\text{where } c_{2j} = \frac{1 \cdot 3 \cdot 5 \cdots (2j-1)}{2^{j+1}} = \frac{(2j)!}{j! 2^{2j+1}}.$$

$$\int \underbrace{x^x}_{m} dx = \sum_{n=0}^m \frac{(-1)^n (n+1)^{n-1}}{n!} \Gamma(n+1, -\ln x) + \sum_{n=m+1}^{\infty} (-1)^n a_{mn} \Gamma(n+1, -\ln x) \quad (\text{for } x > 0)$$

$$\text{where } a_{mn} = \begin{cases} 1 & \text{if } n = 0, \\ \frac{1}{n!} & \text{if } m = 1, \\ \frac{1}{n} \sum_{j=1}^n j a_{m,n-j} a_{m-1,j-1} & \text{otherwise} \end{cases}$$

$$\int \frac{1}{ae^{\lambda x} + b} dx = \frac{x}{b} - \frac{1}{b\lambda} \ln(ae^{\lambda x} + b) \quad \text{when } b \neq 0, \lambda \neq 0 \text{ and } ae^{\lambda x} + b > 0.$$

$$\int_0^1 e^{x \cdot \ln a + (1-x) \cdot \ln b} dx = \int_0^1 \left(\frac{a}{b}\right)^x \cdot b dx = \int_0^1 a^x \cdot b^{1-x} dx = \frac{a-b}{\ln a - \ln b}$$

for $a > 0$, $b > 0$, $a \neq b$, which is the logarithmic mean

$$\int_0^{\infty} e^{-ax} dx = \frac{1}{a}$$

$$\int_0^{\infty} e^{-ax^2} dx = \frac{1}{2} \sqrt{\frac{\pi}{a}} \quad (a > 0)$$

$$\int_{-\infty}^{\infty} e^{-ax^2} dx = \sqrt{\frac{\pi}{a}} \quad (a > 0)$$

$$\int_{-\infty}^{\infty} e^{-ax^2} e^{-2bx} dx = \sqrt{\frac{\pi}{a}} e^{\frac{b^2}{a}} \quad (a > 0) \quad \int_{-\infty}^{\infty} x e^{-a(x-b)^2} dx = b \sqrt{\frac{\pi}{a}}$$

$$\int_{-\infty}^{\infty} x^2 e^{-ax^2} dx = \frac{1}{2} \sqrt{\frac{\pi}{a^3}} \quad (a > 0)$$

$$\int_0^{\infty} x^n e^{-ax^2} dx = \begin{cases} \frac{1}{2} \Gamma\left(\frac{n+1}{2}\right) / a^{\frac{n+1}{2}} & (n > -1, a > 0) \\ \frac{(2k-1)!!}{2^{k+1} a^k} \sqrt{\frac{\pi}{a}} & (n = 2k, k \text{ integer}, a > 0) \\ \frac{k!}{2a^{k+1}} & (n = 2k+1, k \text{ integer}, a > 0) \end{cases}$$

(!! is the double factorial)

$$\int_0^{\infty} x^n e^{-ax} dx = \begin{cases} \frac{\Gamma(n+1)}{a^{n+1}} & (n > -1, a > 0) \\ \frac{n!}{a^{n+1}} & (n = 0, 1, 2, \dots, a > 0) \end{cases}$$

$$\int_0^{\infty} e^{-ax} \sin bx dx = \frac{b}{a^2 + b^2} \quad (a > 0)$$

$$\int_0^{\infty} e^{-ax} \cos bx dx = \frac{a}{a^2 + b^2} \quad (a > 0)$$

$$\int_0^{\infty} x e^{-ax} \sin bx dx = \frac{2ab}{(a^2 + b^2)^2} \quad (a > 0)$$

$$\int_0^{\infty} x e^{-ax} \cos bx dx = \frac{a^2 - b^2}{(a^2 + b^2)^2} \quad (a > 0)$$

$$\int_0^{2\pi} e^{x \cos \theta} d\theta = 2\pi I_0(x) \quad (I_0 \text{ is the modified Bessel function of the first kind})$$

$$\int_0^{2\pi} e^{x \cos \theta + y \sin \theta} d\theta = 2\pi I_0\left(\sqrt{x^2 + y^2}\right)$$

13.20 LOGARITHMIC FUNCTIONS

$$\int \ln(x) dx = x \ln(x) - x + C,$$

$$\int \ln ax dx = x \ln ax - x$$

$$\int \log_a x dx = x(\log_a x - \log_a e) + C$$

$$\int \ln(ax + b) dx = \frac{(ax + b) \ln(ax + b) - (ax)}{a}$$

$$\int (\ln x)^2 dx = x(\ln x)^2 - 2x \ln x + 2x$$

$$\int (\ln x)^n dx = x \sum_{k=0}^n (-1)^{n-k} \frac{n!}{k!} (\ln x)^k$$

$$\int \frac{dx}{\ln x} = \ln |\ln x| + \ln x + \sum_{k=2}^{\infty} \frac{(\ln x)^k}{k \cdot k!}$$

$$\int \frac{dx}{(\ln x)^n} = -\frac{x}{(n-1)(\ln x)^{n-1}} + \frac{1}{n-1} \int \frac{dx}{(\ln x)^{n-1}} \quad (\text{for } n \neq 1)$$

$$\int x^m \ln x dx = x^{m+1} \left(\frac{\ln x}{m+1} - \frac{1}{(m+1)^2} \right) \quad (\text{for } m \neq -1)$$

$$\int x^m (\ln x)^n dx = \frac{x^{m+1} (\ln x)^n}{m+1} - \frac{n}{m+1} \int x^m (\ln x)^{n-1} dx \quad (\text{for } m \neq -1)$$

$$\int \frac{(\ln x)^n dx}{x} = \frac{(\ln x)^{n+1}}{n+1} \quad (\text{for } n \neq -1)$$

$$\int \frac{\ln x^n dx}{x} = \frac{(\ln x^n)^2}{2n} \quad (\text{for } n \neq 0)$$

$$\int \frac{\ln x dx}{x^m} = -\frac{1}{(m-1)x^{m-1}} - \frac{1}{(m-1)^2 x^{m-1}} \quad (\text{for } m \neq 1)$$

$$\int \frac{(\ln x)^n dx}{x^m} = -\frac{(\ln x)^n}{(m-1)x^{m-1}} + \frac{n}{m-1} \int \frac{(\ln x)^{n-1} dx}{x^m} \quad (\text{for } m \neq 1)$$

$$\int \frac{x^m dx}{(\ln x)^n} = -\frac{x^{m+1}}{(n-1)(\ln x)^{n-1}} + \frac{m+1}{n-1} \int \frac{x^m dx}{(\ln x)^{n-1}} \quad (\text{for } n \neq 1)$$

$$\int \frac{dx}{x \ln x} = \ln |\ln x|$$

$$\int \frac{dx}{x^n \ln x} = \ln |\ln x| + \sum_{k=1}^{\infty} (-1)^k \frac{(n-1)^k (\ln x)^k}{k \cdot k!}$$

$$\int \frac{dx}{x(\ln x)^n} = -\frac{1}{(n-1)(\ln x)^{n-1}} \quad (\text{for } n \neq 1)$$

$$\int \ln(x^2 + a^2) dx = x \ln(x^2 + a^2) - 2x + 2a \tan^{-1} \frac{x}{a}$$

$$\int \frac{x}{x^2 + a^2} \ln(x^2 + a^2) dx = \frac{1}{4} \ln^2(x^2 + a^2)$$

$$\int \sin(\ln x) dx = \frac{x}{2} (\sin(\ln x) - \cos(\ln x))$$

$$\int \cos(\ln x) dx = \frac{x}{2} (\sin(\ln x) + \cos(\ln x))$$

$$\int e^x \left(x \ln x - x - \frac{1}{x} \right) dx = e^x (x \ln x - x - \ln x)$$

$$\int \frac{1}{e^x} \left(\frac{1}{x} - \ln x \right) dx = \frac{\ln x}{e^x}$$

$$\int (\ln x)^x dx = (\ln x)^{x-1} + (\ln(\ln x))(\ln x)^x$$

$$\int e^x \left(\frac{1}{\ln x} - \frac{1}{x \ln^2 x} \right) dx = \frac{e^x}{\ln x}$$

13.21 HYPERBOLIC FUNCTIONS

$$\int \sinh ax dx = \frac{1}{a} \cosh ax + C$$

$$\int \cosh ax dx = \frac{1}{a} \sinh ax + C$$

$$\int \sinh^2 ax dx = \frac{1}{4a} \sinh 2ax - \frac{x}{2} + C$$

$$\int \cosh^2 ax dx = \frac{1}{4a} \sinh 2ax + \frac{x}{2} + C$$

$$\int \tanh^2 ax dx = x - \frac{\tanh ax}{a} + C$$

$$\int \sinh^n ax dx = \frac{1}{an} \sinh^{n-1} ax \cosh ax - \frac{n-1}{n} \int \sinh^{n-2} ax dx \quad (\text{for } n > 0)$$

$$\int \sinh^n ax dx = \frac{1}{a(n+1)} \sinh^{n+1} ax \cosh ax - \frac{n+2}{n+1} \int \sinh^{n+2} ax dx \quad (\text{for } n < 0, n \neq -1)$$

$$\int \cosh^n ax dx = \frac{1}{an} \sinh ax \cosh^{n-1} ax + \frac{n-1}{n} \int \cosh^{n-2} ax dx \quad (\text{for } n > 0)$$

$$\int \cosh^n ax dx = -\frac{1}{a(n+1)} \sinh ax \cosh^{n+1} ax - \frac{n+2}{n+1} \int \cosh^{n+2} ax dx \quad (\text{for } n < 0, n \neq -1)$$

$$\int \frac{dx}{\sinh ax} = \frac{1}{a} \ln \left| \tanh \frac{ax}{2} \right| + C$$

$$\int \frac{dx}{\sinh ax} = \frac{1}{a} \ln \left| \frac{\cosh ax - 1}{\sinh ax} \right| + C$$

$$\int \frac{dx}{\sinh ax} = \frac{1}{a} \ln \left| \frac{\sinh ax}{\cosh ax + 1} \right| + C$$

$$\int \frac{dx}{\sinh ax} = \frac{1}{a} \ln \left| \frac{\cosh ax - 1}{\cosh ax + 1} \right| + C$$

$$\int \frac{dx}{\cosh ax} = \frac{2}{a} \operatorname{arctan} e^{ax} + C$$

$$\int \frac{dx}{\sinh^n ax} = -\frac{\cosh ax}{a(n-1) \sinh^{n-1} ax} - \frac{n-2}{n-1} \int \frac{dx}{\sinh^{n-2} ax} \quad (\text{for } n \neq 1)$$

$$\int \frac{dx}{\cosh^n ax} = \frac{\sinh ax}{a(n-1) \cosh^{n-1} ax} + \frac{n-2}{n-1} \int \frac{dx}{\cosh^{n-2} ax} \quad (\text{for } n \neq 1)$$

$$\int \frac{\cosh^n ax}{\sinh^m ax} dx = \frac{\cosh^{n-1} ax}{a(n-m) \sinh^{m-1} ax} + \frac{n-1}{n-m} \int \frac{\cosh^{n-2} ax}{\sinh^m ax} dx \quad (\text{for } m \neq n)$$

$$\int \frac{\cosh^n ax}{\sinh^m ax} dx = -\frac{\cosh^{n+1} ax}{a(m-1)\sinh^{m-1} ax} + \frac{n-m+2}{m-1} \int \frac{\cosh^n ax}{\sinh^{m-2} ax} dx \quad (\text{for } m \neq 1)$$

$$\int \frac{\cosh^n ax}{\sinh^m ax} dx = -\frac{\cosh^{n-1} ax}{a(m-1)\sinh^{m-1} ax} + \frac{n-1}{m-1} \int \frac{\cosh^{n-2} ax}{\sinh^{m-2} ax} dx \quad (\text{for } m \neq 1)$$

$$\int \frac{\sinh^m ax}{\cosh^n ax} dx = \frac{\sinh^{m-1} ax}{a(m-n)\cosh^{n-1} ax} + \frac{m-1}{n-m} \int \frac{\sinh^{m-2} ax}{\cosh^n ax} dx \quad (\text{for } m \neq n)$$

$$\int \frac{\sinh^m ax}{\cosh^n ax} dx = \frac{\sinh^{m+1} ax}{a(n-1)\cosh^{n-1} ax} + \frac{m-n+2}{n-1} \int \frac{\sinh^m ax}{\cosh^{n-2} ax} dx \quad (\text{for } n \neq 1)$$

$$\int \frac{\sinh^m ax}{\cosh^n ax} dx = -\frac{\sinh^{m-1} ax}{a(n-1)\cosh^{n-1} ax} + \frac{m-1}{n-1} \int \frac{\sinh^{m-2} ax}{\cosh^{n-2} ax} dx \quad (\text{for } n \neq 1)$$

$$\int x \sinh ax dx = \frac{1}{a} x \cosh ax - \frac{1}{a^2} \sinh ax + C$$

$$\int x \cosh ax dx = \frac{1}{a} x \sinh ax - \frac{1}{a^2} \cosh ax + C$$

$$\int x^2 \cosh ax dx = -\frac{2x \cosh ax}{a^2} + \left(\frac{x^2}{a} + \frac{2}{a^3} \right) \sinh ax + C$$

$$\int \tanh ax dx = \frac{1}{a} \ln |\cosh ax| + C$$

$$\int \coth ax dx = \frac{1}{a} \ln |\sinh ax| + C$$

$$\int \tanh^n ax dx = -\frac{1}{a(n-1)} \tanh^{n-1} ax + \int \tanh^{n-2} ax dx \quad (\text{for } n \neq 1)$$

$$\int \coth^n ax dx = -\frac{1}{a(n-1)} \coth^{n-1} ax + \int \coth^{n-2} ax dx \quad (\text{for } n \neq 1)$$

$$\int \sinh ax \sinh bx dx = \frac{1}{a^2 - b^2} (a \sinh bx \cosh ax - b \cosh bx \sinh ax) + C \quad (\text{for } a^2 \neq b^2)$$

$$\int \cosh ax \cosh bx dx = \frac{1}{a^2 - b^2} (a \sinh ax \cosh bx - b \sinh bx \cosh ax) + C \quad (\text{for } a^2 \neq b^2)$$

$$\int \cosh ax \sinh bx dx = \frac{1}{a^2 - b^2} (a \sinh ax \sinh bx - b \cosh ax \cosh bx) + C \quad (\text{for } a^2 \neq b^2)$$

$$\int \sinh(ax+b) \sin(cx+d) dx = \frac{a}{a^2 + c^2} \cosh(ax+b) \sin(cx+d) - \frac{c}{a^2 + c^2} \sinh(ax+b) \cos(cx+d) + C$$

$$\int \sinh(ax+b) \cos(cx+d) dx = \frac{a}{a^2 + c^2} \cosh(ax+b) \cos(cx+d) + \frac{c}{a^2 + c^2} \sinh(ax+b) \sin(cx+d) + C$$

$$\int \cosh(ax+b) \sin(cx+d) dx = \frac{a}{a^2 + c^2} \sinh(ax+b) \sin(cx+d) - \frac{c}{a^2 + c^2} \cosh(ax+b) \cos(cx+d) + C$$

$$\int \cosh(ax+b) \cos(cx+d) dx = \frac{a}{a^2 + c^2} \sinh(ax+b) \cos(cx+d) + \frac{c}{a^2 + c^2} \cosh(ax+b) \sin(cx+d) + C$$

13.22 INVERSE HYPERBOLIC FUNCTIONS

$$\int \operatorname{arsinh} \frac{x}{a} dx = x \operatorname{arsinh} \frac{x}{a} - \sqrt{x^2 + a^2} + C$$

$$\int \operatorname{arcosh} \frac{x}{a} dx = x \operatorname{arcosh} \frac{x}{a} - \sqrt{x^2 - a^2} + C$$

$$\int \operatorname{artanh} \frac{x}{a} dx = x \operatorname{artanh} \frac{x}{a} + \frac{a}{2} \ln |a^2 - x^2| + C \quad (\text{for } |x| < |a|)$$

$$\int \operatorname{arcoth} \frac{x}{a} dx = x \operatorname{arcoth} \frac{x}{a} + \frac{a}{2} \ln |x^2 - a^2| + C \quad (\text{for } |x| > |a|)$$

$$\int \operatorname{arsech} \frac{x}{a} dx = x \operatorname{arsech} \frac{x}{a} - a \arctan \frac{x \sqrt{\frac{a-x}{a+x}}}{x-a} + C \quad (\text{for } x \in (0, a))$$

$$\int \operatorname{arcsch} \frac{x}{a} dx = x \operatorname{arcsch} \frac{x}{a} + a \ln \frac{x + \sqrt{x^2 + a^2}}{a} + C \quad (\text{for } x \in (0, a))$$

13.23 ABSOLUTE VALUE FUNCTIONS

$$\int |(ax + b)^n| dx = \frac{(ax + b)^{n+2}}{a(n+1)|ax + b|} + C \quad [n \text{ is odd, and } n \neq -1]$$

$$\int |\sin ax| dx = \frac{-1}{a} |\sin ax| \cot ax + C$$

$$\int |\cos ax| dx = \frac{1}{a} |\cos ax| \tan ax + C$$

$$\int |\tan ax| dx = \frac{\tan(ax)[- \ln |\cos ax|]}{a |\tan ax|} + C$$

$$\int |\csc ax| dx = \frac{- \ln |\csc ax + \cot ax| \sin ax}{a |\sin ax|} + C$$

$$\int |\sec ax| dx = \frac{\ln |\sec ax + \tan ax| \cos ax}{a |\cos ax|} + C$$

$$\int |\cot ax| dx = \frac{\tan(ax)[\ln |\sin ax|]}{a |\tan ax|} + C$$

13.24 SUMMARY TABLE

$$\int \frac{f'(u)}{f(u)} du = \ln |f(u)| + C, \quad \int (f(u))^n f'(u) du = \frac{(f(u))^{n+1}}{n+1} + C$$

$$\int \sin u du = -\cos u + C, \quad \int \cos u du = \sin u + C, \quad \int \sec^2 u du = \tan u + C$$

$$\int \tan u du = \ln |\sec u| + C, \quad \int \tanh u du = \ln(\cosh u) + C$$

$$\int \cot u du = \ln |\sin u| + C, \quad \int \coth u du = \ln |\sinh u| + C$$

$$\int \sec u du = \ln |\sec u + \tan u| + C, \quad \int \operatorname{sech} u du = \tan^{-1} |\sinh u| + C$$

$$\int \operatorname{cosec} u du = \ln |\operatorname{cosec} u - \cot u| + C, \quad \int \operatorname{cosech} u du = \ln \left| \tanh \frac{u}{2} \right| + C$$

$$\int \frac{du}{a^2 - u^2} = \frac{1}{2a} \ln \left| \frac{u+a}{u-a} \right| + C, \quad \int \frac{du}{u^2 - a^2} = \frac{1}{2a} \ln \left| \frac{u-a}{u+a} \right| + C$$

$$\int \frac{du}{\sqrt{a^2 - u^2}} = \sin^{-1} \left(\frac{u}{a} \right) + C, \quad \int \frac{du}{a^2 + u^2} = \frac{1}{a} \tan^{-1} \left(\frac{u}{a} \right) + C$$

$$\int \frac{du}{u\sqrt{u^2 - a^2}} = \frac{1}{a} \sec^{-1} \left(\frac{u}{a} \right) + C$$

$$\int \frac{du}{\sqrt{u^2 + a^2}} = \sinh^{-1} \left(\frac{u}{a} \right) + C = \ln |u + \sqrt{u^2 + a^2}| + C$$

$$\int \frac{du}{\sqrt{u^2 - a^2}} = \cosh^{-1} \left(\frac{u}{a} \right) + C = \ln |u + \sqrt{u^2 - a^2}| + C$$

$$\int \frac{du}{u\sqrt{a^2 - u^2}} = -\frac{1}{a} \operatorname{sech}^{-1} \left(\frac{u}{a} \right) + C = -\frac{1}{a} \ln \left| \frac{a + \sqrt{a^2 - u^2}}{u} \right| + C$$

13.25 SQUARE ROOT PROOFS

$$\int \sqrt{a^2 + x^2} dx$$

$$\text{Let } x = a \tan \theta \therefore dx = a \sec^2 \theta d\theta \rightarrow \tan \theta = \frac{x}{a}$$

$$= \int \sqrt{a^2 + (a \tan \theta)^2} \times a \sec^2 \theta d\theta$$

$$= \int \sqrt{a^2 + a^2 \tan^2 \theta} \times a \sec^2 \theta d\theta$$

$$= \int \sqrt{a^2 + a^2 (\sec^2 \theta - 1)} \times a \sec^2 \theta d\theta$$

$$= \int \sqrt{a^2 + a^2 \sec^2 \theta - a^2} \times a \sec^2 \theta d\theta$$

$$= \int \sqrt{a^2 \sec^2 \theta} \times a \sec^2 \theta d\theta$$

$$= \int a \sec \theta \times a \sec^2 \theta d\theta$$

$$= \int a^2 \sec^3 \theta d\theta$$

$$= a^2 \int \sec \theta \times \sec^2 \theta d\theta$$

$$u = \sec \theta, dv = \sec^2 \theta d\theta$$

$$du = \sec \theta \tan \theta d\theta, v = \tan \theta$$

$$\therefore a^2 \int \sec^3 \theta d\theta = \sec \theta \times \tan \theta - \int \tan \theta \times \sec \theta \tan \theta d\theta$$

$$a^2 \int \sec^3 \theta d\theta = \sec \theta \tan \theta - \int \tan^2 \theta \sec \theta d\theta$$

$$a^2 \int \sec^3 \theta d\theta = \sec \theta \tan \theta - \int (\sec^2 \theta - 1) \sec \theta d\theta$$

$$a^2 \int \sec^3 \theta d\theta = \sec \theta \tan \theta - \int \sec^3 \theta - \sec \theta d\theta$$

$$a^2 \int \sec^3 \theta d\theta = \sec \theta \tan \theta - \int \sec^3 \theta d\theta + \int \sec \theta d\theta$$

$$2a^2 \int \sec^3 \theta d\theta = \sec \theta \tan \theta + \int \sec \theta d\theta$$

$$\int \sec^3 \theta d\theta = \frac{1}{2a^2} (\sec \theta \tan \theta + \int \sec \theta d\theta)$$

$$\int \sec^3 \theta d\theta = \frac{1}{2a^2} (\sec \theta \tan \theta + \ln |\sec \theta + \tan \theta|) + C$$

$$\therefore \int \sqrt{a^2 + x^2} dx = \frac{1}{2a^2} \left(\frac{\sqrt{a^2 + x^2}}{a} \times \frac{x}{a} + \ln \left| \frac{\sqrt{a^2 + x^2}}{a} + \frac{x}{a} \right| \right) + C$$

$$\int \sqrt{a^2 - x^2} dx$$

$$\text{Let } x = a \sin \theta \therefore dx = a \cos \theta d\theta \rightarrow \sin \theta = \frac{x}{a}$$

$$= \int \sqrt{a^2 - (a \sin \theta)^2} \times a \cos \theta d\theta$$

$$= \int \sqrt{a^2 - a^2 \sin^2 \theta} \times a \cos \theta d\theta$$

$$= \int \sqrt{a^2 - a^2(1 - \cos^2 \theta)} \times a \cos \theta d\theta$$

$$= \int \sqrt{a^2 - a^2 + a^2 \cos^2 \theta} \times a \cos \theta d\theta$$

$$= \int \sqrt{a^2 \cos^2 \theta} \times a \cos \theta d\theta$$

$$= \int a \cos \theta \times a \cos \theta d\theta$$

$$= \int a^2 \cos^2 \theta d\theta$$

$$= a^2 \int \cos^2 \theta d\theta$$

$$= a^2 \int \frac{1 + \cos(2\theta)}{2} d\theta$$

$$= \frac{a^2}{2} \int 1 + \cos(2\theta) d\theta$$

$$= \frac{a^2}{2} \left[\theta + \frac{\sin(2\theta)}{2} \right] + C$$

$$= \frac{a^2}{2} \left[\theta + \frac{2 \sin \theta \cos \theta}{2} \right] + C$$

$$= \frac{a^2}{2} [\theta + \sin \theta \cos \theta] + C$$

$$= \frac{a^2}{2} \left[\arcsin\left(\frac{x}{a}\right) + \frac{x}{a} \times \frac{\sqrt{a^2 - x^2}}{a} \right] + C$$

$$\int \sqrt{x^2 - a^2} dx$$

$$\text{Let } x = a \sec \theta \therefore dx = a \sec \theta \tan \theta d\theta \rightarrow \sec \theta = \frac{x}{a}$$

$$= \int \sqrt{(a \sec \theta)^2 - a^2} \times a \sec \theta \tan \theta d\theta$$

$$= \int \sqrt{a^2 \sec^2 \theta - a^2} \times a \sec \theta \tan \theta d\theta$$

$$= \int \sqrt{a^2(1 + \tan^2 \theta) - a^2} \times a \sec \theta \tan \theta d\theta$$

$$= \int \sqrt{a^2 + a^2 \tan^2 \theta - a^2} \times a \sec \theta \tan \theta d\theta$$

$$= \int \sqrt{a^2 \tan^2 \theta} \times a \sec \theta \tan \theta d\theta$$

$$= \int a \tan \theta \times a \sec \theta \tan \theta d\theta$$

$$= \int a^2 \tan^2 \theta \sec \theta d\theta$$

$$= a^2 \int \tan^2 \theta \sec \theta d\theta$$

$$= a^2 \int (\sec^2 \theta - 1) \sec \theta d\theta$$

$$= a^2 \int \sec^3 \theta - \sec \theta d\theta$$

$$= a^2 \left(\int \sec^3 \theta d\theta - \int \sec \theta d\theta \right)$$

$$= a^2 \left(\left(\frac{1}{2a^2} (\sec \theta \tan \theta + \ln |\sec \theta + \tan \theta|) \right) - (\ln |\sec \theta + \tan \theta|) \right) + C$$

$$= \frac{1}{2} (\sec \theta \tan \theta + \ln |\sec \theta + \tan \theta|) - a^2 (\ln |\sec \theta + \tan \theta|) + C$$

$$= \frac{1}{2} \left(\frac{x}{a} \times \frac{\sqrt{x^2 - a^2}}{a} + \ln \left| \frac{x}{a} + \frac{\sqrt{x^2 - a^2}}{a} \right| \right) - a^2 \left(\ln \left| \frac{x}{a} + \frac{\sqrt{x^2 - a^2}}{a} \right| \right) + C$$

$$= \frac{1}{2} \frac{x \times \sqrt{x^2 - a^2}}{a^2} + \frac{1}{2} \ln \left| \frac{x}{a} + \frac{\sqrt{x^2 - a^2}}{a} \right| - \ln \left| \frac{x}{a} + \frac{\sqrt{x^2 - a^2}}{a} \right| + C$$

$$= \frac{1}{2} \frac{x \times \sqrt{x^2 - a^2}}{a^2} + \left(\frac{1}{2} - a^2 \right) \ln \left| \frac{x}{a} + \frac{\sqrt{x^2 - a^2}}{a} \right| + C$$

13.26 CARTESIAN APPLICATIONS

Area under the curve: $A = \int_a^b f(x) dx$

Volume: $V = \int_a^b A$

Volume about x axis: $V_x = \pi \int_a^b [y]^2 dx = \pi \int_a^b [f(x)]^2 dx$

Volume about y axis: $V_y = \pi \int_c^d [x]^2 dy$

Surface Area about x axis: $SA = 2\pi \int_a^b f_{(x)} \sqrt{1 + (f'_{(x)})^2} dx$

Length wrt x-ordinates: $L = \int_a^b \sqrt{1 + \left(\frac{dy}{dx}\right)^2} dx$

Length wrt y-ordinates: $L = \int_c^d \sqrt{1 + \left(\frac{dx}{dy}\right)^2} dy$ (Where the function is continually increasing)

Length parametrically: $L = \int_{t1}^{t2} \sqrt{\left(\frac{dx}{dt}\right)^2 + \left(\frac{dy}{dt}\right)^2} dt$

PART 14: FUNCTIONS

14.1 COMPOSITE FUNCTIONS:

Odd \pm Odd = Odd
 Odd \pm Even = Neither
 Even \pm Even = Even
 Odd \times Odd = Even
 Odd / Odd = Odd
 Even \times Even = Even
 Even / Even = Even
 Even of Odd = Even
 Even of Even = Even
 Even of Neither = Neither
 Odd of Odd = Odd
 Odd of Even = Even
 Odd of Neither = Neither

If $f(x)$ is odd:
$$\int_{-a}^a f(x)dx = 0$$

If $f(x)$ is even:
$$\int_{-a}^a f(x)dx = 2 \int_0^a f(x)dx$$

14.2 MULTIVARIABLE FUNCTIONS:

Limit:
$$\lim_{(x,y) \rightarrow (0,0)} (f_{(x,y)}) = \lim_{(x,mx) \rightarrow (0,0)} (f_{(x,mx)}) = \lim_{(x) \rightarrow (0)} (f_{(x,mx)})$$

Discriminant:
$$D_{(x_0,y_0)} = z_{xx}z_{yy} - (z_{xy})^2$$

Critical Points:
$$z = f_{(x,y)}$$

Solve for:
$$\left. \begin{aligned} z_x &= 0 \\ z_y &= 0 \end{aligned} \right\}$$

- If the critical point (x_0,y_0) is a local maximum, then

$$D(x_0,y_0) >= 0$$

$$f_{xx}(x_0,y_0) <= 0 \text{ and } f_{yy}(x_0,y_0) <= 0$$

- If $D(x_0,y_0) > 0$, and either

$$f_{xx}(x_0,y_0) < 0 \text{ or } f_{yy}(x_0,y_0) < 0$$

then the critical point (x_0,y_0) is a local maximum.

- If the critical point (x_0,y_0) is a local minimum, then

$$D(x_0,y_0) >= 0$$

$$f_{xx}(x_0,y_0) >= 0 \text{ and } f_{yy}(x_0,y_0) >= 0$$

- If $D(x_0,y_0) > 0$, and either

$$f_{xx}(x_0,y_0) > 0 \text{ or } f_{yy}(x_0,y_0) > 0$$

then the critical point (x_0,y_0) is a local minimum.

□ If the critical point (x_0, y_0) is a saddle point, then

$$D(x_0, y_0) \leq 0$$

□ If

$$D(x_0, y_0) < 0,$$

then the critical point (x_0, y_0) is a saddle point.

14.3 FIRST ORDER, FIRST DEGREE, DIFFERENTIAL EQUATIONS:

Separable:

$$\frac{dy}{dx} = \frac{f(x)}{g(y)}$$

$$g(y)dy = f(x)dx$$

$$\int g(y)dy = \int f(x)dx$$

Linear:

$$\frac{dy}{dx} + P(x)y = Q(x)$$

$$I(x) = e^{\int P(x)dx}$$

$$y = \frac{1}{I(x)} \left(\int I(x)Q(x)dx \right)$$

Homogeneous:

$$f(\lambda x, \lambda y) = f(x, y)$$

$$\frac{dy}{dx} = f(x, y) = F\left(\frac{y}{x}\right)$$

$$\text{Let } v(x) = \frac{y}{x}, \therefore \frac{dy}{dx} = v + x \frac{dv}{dx}$$

$$\therefore v + x \frac{dv}{dx} = F(v)$$

$$x \frac{dv}{dx} = F(v) - v$$

$$\frac{dv}{F(v) - v} = \frac{dx}{x}$$

$$\int \frac{dv}{F(v) - v} = \int \frac{dx}{x}$$

Exact:

$$\frac{dy}{dx} = f(x, y) \rightarrow M(x, y)dx + N(x, y)dy = 0$$

$$\text{If: } M_y = N_x$$

$$\text{When: } F_x = M \text{ \& } F_y = N$$

Therefore,

$$F = \int M(x, y)dx = \Phi(x, y) + g(y)$$

$$F_y = \frac{\partial}{\partial y}(\Phi + g(y)) = \Phi_y + g'(y) = N$$

$$\therefore g(y) = \dots$$

$$\text{So: } F(x, y) = \Phi(x, y) + g(y) = C$$

14.4 SECOND ORDER

Where $a \frac{d^2 y}{dx^2} + b \frac{dy}{dx} + cy = f(x)$

$$ay'' + by' + cy = f(x)$$

Homogeneous:

$$ay'' + by' + cy = 0$$

$$\Rightarrow am^2 + bm + c = 0$$

$$m = \frac{-b \pm \sqrt{b^2 - 4ac}}{2a}$$

There are three possible outcomes:

- 1) m_1, m_2 where $m_1 \neq m_2 \Rightarrow y_h = Ae^{m_1 x} + Be^{m_2 x}$
- 2) m_1, m_2 where $m_1 = m_2 \Rightarrow y_h = (A + Bx)e^{m_1 x}$
- 3) $m_{1,2} = \alpha \pm \beta j \Rightarrow y_h = e^{\alpha x} (A \cos(\beta x) + B \sin(\beta x))$

Undetermined Coefficients

Where $f(x)$ is in the form of

- 1) A polynomial $\Rightarrow y_p = A_n x^n + A_{n-1} x^{n-1} + A_1 x + A_0$
- 2) $\alpha \sin(kx)$ $\Rightarrow y_p = A \sin(kx) + B \cos(kx)$
- 3) αe^{kt} $\Rightarrow y_p = Ae^{kt}$

NB: Multiplication is OK: eg:

$$f(x) = 3x^3 e^x$$

$$y_p = (Ae^x)(Bx^3 + Cx^2 + Dx + E)$$

$$y_p = (e^x)(Bx^3 + Cx^2 + Dx + E)$$

NB: If y_p is part of y_c , you multiply y_p by x

To determine the unknown variables, substitute back into the original equation with

y_p, y'_p, y''_p and compare the coefficients.

Then,

$$y = y_h + y_{p1} + y_{p2} + y_{p3} + \dots$$

Variation of Parameters

$$y_h = c_1 u_1(x) + c_2 u_2(x)$$

$$y_p = v_1(x)u_1(x) + v_2(x)u_2(x)$$

Where,

$$v_1' = \frac{-u_2(x)f(x)}{\Delta}, v_2' = \frac{u_1(x)f(x)}{\Delta}, \Delta = \begin{vmatrix} u_1 & u_2 \\ u_1' & u_2' \end{vmatrix} = u_1 u_2' - u_2 u_1'$$

$$\therefore v_1 = \int \frac{-u_2(x)f(x)}{u_1 u_2' - u_2 u_1'} dx, v_2 = \int \frac{u_1(x)f(x)}{u_1 u_2' - u_2 u_1'} dx$$

PART 15: MATRICIES

15.1 BASIC PRINICIPLES:

Size = $i \times j$, i=row, j=column

$$A = [a_{ij}]$$

15.2 BASIC OPERTAIONS:

Addition: $A + B = [a_{ij} + b_{ij}]$

Subtraction: $A - B = [a_{ij} - b_{ij}]$

Scalar Multiple: $kA = [ka_{ij}]$

Transpose: $[A^T]_{ij} = A_{ji}$

eg:
$$\begin{bmatrix} 1 & 2 & 3 \\ 0 & -6 & 7 \end{bmatrix}^T = \begin{bmatrix} 1 & 0 \\ 2 & -6 \\ 3 & 7 \end{bmatrix}$$

$$(A + B + C + \dots)^T = A^T + B^T + C^T + \dots$$

$$(ABCD\dots)^T = \dots D^T C^T B^T A^T$$

Scalar Product: $a \bullet b = [a_1 \quad a_2 \quad a_3 \quad \dots] \begin{bmatrix} b_1 \\ b_2 \\ b_3 \\ \dots \end{bmatrix}$

Symmetry: $A^T = A$

Cramer's Rule:

$$Ax = B$$

$$x_i = \frac{\det(A_i)}{\det(A)} \text{ where } A_i = \text{column } i \text{ replaced by } B$$

Least Squares Solution

In the form $A\underline{x} = \underline{b}$, $\underline{x} = (A^T A)^{-1} A^T \underline{b}$

For a linear approximation: $r_0 + r_1 x = b$

For a quadratic approximation: $r_0 + r_1 x + r_2 x^2 = b$

Etc.

15.3 SQUARE MATRIX:

Diagonal:
$$\begin{bmatrix} d_{11} & 0 & 0 \\ 0 & d_{22} & 0 \\ 0 & 0 & d_{33} \end{bmatrix}$$

Lower Triangle Matrix:
$$\begin{bmatrix} l_{11} & 0 & 0 \\ l_{21} & l_{22} & 0 \\ l_{31} & l_{32} & l_{33} \end{bmatrix}$$

Upper Triangle Matrix:
$$\begin{bmatrix} u_{11} & u_{12} & u_{13} \\ 0 & u_{22} & u_{23} \\ 0 & 0 & u_{33} \end{bmatrix}$$

15.4 DETERMINATE:

2x2: $\det(A) = ad - bc$

3x3: $\det(A) = aei + bfg + cdh - afh - bdi - ceg$

nxn: $\det(A) = a_{11}C_{11} + a_{12}C_{12} + a_{1n}C_{1n} = \sum_{j=1}^n a_{1j}C_{1j} = \sum_{j=1}^n a_{1j}M_{1j} \times (-1)^{(1+j)}$

Rules:

1. If A has a row or a column of zeros, $\det(A) = 0$.

e.g.
$$\begin{vmatrix} 5 & 0 & 6 & -1 \\ 0 & 0 & 8 & -2 \\ 1 & 0 & -3 & 4 \\ 3 & 0 & 0 & 1 \end{vmatrix} = 0 \text{ and } \begin{vmatrix} 1 & 2 & 3 \\ 0 & 0 & 0 \\ 0 & 3 & -1 \end{vmatrix} = 0.$$

2. Multiply any one row of A by a scalar k to obtain A' . Then

$$\det(A') = k \det(A)$$

(makes sense when you consider taking a cofactor expansion along that row) *e.g.*

$$\begin{vmatrix} 1 & 3 \\ -1 & 2 \end{vmatrix} = 5 \text{ and } \begin{vmatrix} 3 & 9 \\ -1 & 2 \end{vmatrix} = 15, \text{ as expected}$$

3. Interchange any two rows in A to obtain A' . Then

$$\det(A') = -\det(A)$$

e.g.
$$\begin{vmatrix} 13 & 1 \\ 2 & -1 \end{vmatrix} = -15 \text{ and } \begin{vmatrix} 2 & -1 \\ 13 & 1 \end{vmatrix} = 15, \text{ as expected.}$$

4. Add a multiple of one row in A to another to obtain A' . Then

$$\det(A') = \det(A)$$

e.g. let $A = \begin{bmatrix} 1 & 3 \\ -3 & 5 \end{bmatrix}$, then $\det(A) = 14$. Consider $\begin{bmatrix} 1 & 3 \\ -3 & 5 \end{bmatrix} \xrightarrow{R_2 \rightarrow R_2 + 3R_1}$
 $\sim \begin{bmatrix} 1 & 3 \\ 0 & 14 \end{bmatrix} = A'$ and $\det(A') = 14$, as expected.

Note that Rules 2, 3 and 4 deal in particular with how elementary row operation affect the determinant of a matrix. Rule 4 is particularly useful as it allows us to induce additional zeros in a matrix to simplify the determinant calculation.

Ex: Evaluate $\begin{vmatrix} 2 & -1 & 3 \\ 1 & 2 & 6 \\ -3 & 5 & 1 \end{vmatrix}$.

Soln: $\begin{vmatrix} 2 & -1 & 3 \\ 1 & 2 & 6 \\ -3 & 5 & 1 \end{vmatrix} \xrightarrow{\substack{R_1 \rightarrow R_1 - 2R_2 \\ R_3 \rightarrow R_3 + 3R_2}} = \begin{vmatrix} 0^+ & -5 & -9 \\ 1^- & 2 & 6 \\ 0^+ & 11 & 19 \end{vmatrix} = - \begin{vmatrix} -5 & -9 \\ 11 & 19 \end{vmatrix} = -4$.

5. If one row in A is a scalar multiple of another, then $\det(A) = 0$. This makes sense, since we can then apply an e.r.o. to get a zero row before applying Rule 1. *e.g.*

$$\begin{vmatrix} 3 & -1 & 4 & 7 \\ 2 & 2 & 3 & -1 \\ -3 & 1 & -4 & -7 \\ 1 & 6 & 2 & 1 \end{vmatrix} = 0, \text{ since } R_3 = -R_1.$$

6. $\det(A^T) = \det(A)$. This rule basically allows us to apply Rules 1-5 to columns as well as rows.

Ex: $\begin{vmatrix} 2 & 1 & 0 & -1 \\ -5 & 0 & 4 & 2 \\ 1 & -3 & 0 & 4 \\ 0 & 0 & -1 & -2 \end{vmatrix} \xrightarrow{R_3 \rightarrow R_3 + 3R_1} = \begin{vmatrix} 2^+ & 1^- & 0 & -1 \\ -5 & 0^+ & 4 & 2 \\ 7 & 0^- & 0 & 1 \\ 0 & 0^+ & 1 & -2 \end{vmatrix} = - \begin{vmatrix} -5 & 4 & 2 \\ 7 & 0 & 1 \\ 0 & -1 & -2 \end{vmatrix} \xrightarrow{C_3 \rightarrow C_3 - 2C_2}$
 $= - \begin{vmatrix} -5^+ & 4 & -6 \\ 7^- & 0 & 1 \\ 0^+ & -1^- & 0^+ \end{vmatrix} = -(-(-1)) \begin{vmatrix} -5 & -6 \\ 7 & 1 \end{vmatrix} = -(-5 + 42) = -37$.

7. $\det(kA) = k^n \det(A)$ (This is simply an expanded version of Rule 2.)

8. $\det(AB) = \det(A) \det(B)$ This is not an obvious rule, but a very important one

which is used frequently in practice. *e.g.* let $A = \begin{bmatrix} 2 & 3 \\ 4 & 1 \end{bmatrix}$ and $B = \begin{bmatrix} -1 & 2 \\ 3 & 1 \end{bmatrix}$.

Then $\det(A) = 2 - 12 = -10$, $\det(B) = -1 - 6 = -7$, $AB = \begin{bmatrix} 7 & 7 \\ -1 & 9 \end{bmatrix}$ and $\det(AB) = 63 - (-7) = 70 = \det(A) \det(B)$, as expected.

9. An **upper triangular matrix** is square with all entries below the main diagonal equal to zero. A **lower triangular matrix** is square with all entries above the main diagonal equal to zero. Finally, the determinant of a lower triangular or upper triangular matrix is the product of all the diagonal elements. For example,

$$(i) \begin{vmatrix} 1 & 2 & 3 \\ 0 & 4 & 2 \\ 0 & 0 & 2 \end{vmatrix} = (1) \begin{vmatrix} 4 & 2 \\ 0 & 2 \end{vmatrix} = (1)((4)(2) - (0)(2)) = (1)(4)(2) = 8.$$

$$(ii) \begin{vmatrix} 2 & 0 & 0 & 0 \\ 4 & 1 & 0 & 0 \\ 3 & 0 & 5 & 0 \\ -1 & 1 & 2 & 4 \end{vmatrix} = (2) \begin{vmatrix} 1 & 0 & 0 \\ 0 & 5 & 0 \\ 1 & 2 & 4 \end{vmatrix} = (2)(1) \begin{vmatrix} 5 & 0 \\ 2 & 4 \end{vmatrix} = (2)(1)(5)(4) = 40.$$

In particular, note that the identity matrix is both upper and lower triangular, so $\det(I) = 1^n = 1$ for any order n .

10. A square matrix A is invertible if and only if $\det(A) \neq 0$. This is the most important rule of determinants.

From Rule 10, it follows that:

- (i) $\det(A) = 0$ shows that A is singular, *i.e.* A^{-1} does not exist. Compare this with the case of a scalar a . If $|a| = 0$ (*i.e.* if $a = 0$), then $a^{-1} = \frac{1}{a}$ also does not exist.

$\det(A) \neq 0$ shows that A is non-singular, *i.e.* A^{-1} does exist.

- (ii) Note that if A is non-singular, then $AA^{-1} = I$. Hence,

$$\begin{aligned} \text{i.e.} \quad \det(AA^{-1}) &= \det(I) \\ \text{i.e.} \quad \det(A)\det(A^{-1}) &= 1 \\ \text{i.e.} \quad \det(A^{-1}) &= \frac{1}{\det(A)} \end{aligned}$$

15.5 INVERSE

2x2:
$$\begin{bmatrix} a & b \\ c & d \end{bmatrix}^{-1} = \frac{1}{ad-bc} \begin{bmatrix} d & -b \\ -c & a \end{bmatrix}$$

3x3:

$$\begin{bmatrix} a & b & c \\ d & e & f \\ g & h & i \end{bmatrix}^{-1} = \frac{1}{aei-afh-bdi+ bfg+ cdh- ceg} \begin{bmatrix} ei-fh & ch-bi & bf-ce \\ fg-di & ai-cg & cd-af \\ dh-eg & bg-ah & ae-bd \end{bmatrix}$$

Minor: M_{ij} = Determinate of Sub matrix which has deleted row i and column j

$$A = \begin{bmatrix} a & b & c \\ d & e & f \\ g & h & i \end{bmatrix}$$

$$M_{21} = \begin{bmatrix} b & c \\ h & f \end{bmatrix}$$

Cofactor: $C_{ij} = M_{ij} \times (-1)^{(i+j)}$

Adjoint Method for Inverse:

$$\text{adj}(A) = C^T$$

$$A^{-1} = \frac{1}{\det(A)} \text{adj}(A)$$

Ex: Find the adjoint of $A = \begin{bmatrix} 1^+ & 2^- & 1^+ \\ -1^- & 0^+ & 2^- \\ 1^+ & 1^- & 0^+ \end{bmatrix}$.

Soln: $C_{11} = + \begin{vmatrix} 0 & 2 \\ 1 & 0 \end{vmatrix} = -2$, $C_{12} = - \begin{vmatrix} -1 & 2 \\ 1 & 0 \end{vmatrix} = 2$, $C_{13} = + \begin{vmatrix} -1 & 0 \\ 1 & 1 \end{vmatrix} = -1$, $C_{21} = - \begin{vmatrix} 2 & 1 \\ 1 & 0 \end{vmatrix} = 1$, $C_{22} = + \begin{vmatrix} 1 & 1 \\ 1 & 0 \end{vmatrix} = -1$, $C_{23} = - \begin{vmatrix} 1 & 2 \\ 1 & 1 \end{vmatrix} = 1$, $C_{31} = + \begin{vmatrix} 2 & 1 \\ 0 & 2 \end{vmatrix} = 4$, $C_{32} = - \begin{vmatrix} 1 & 1 \\ -1 & 2 \end{vmatrix} = -3$, $C_{33} = + \begin{vmatrix} 1 & 2 \\ -1 & 0 \end{vmatrix} = 2$.

Hence, $C = \begin{bmatrix} -2 & 2 & -1 \\ 1 & -1 & 1 \\ 4 & -3 & 2 \end{bmatrix}$ and $\text{adj}(A) = C^T = \begin{bmatrix} -2 & 1 & 4 \\ 2 & -1 & -3 \\ -1 & 1 & 2 \end{bmatrix}$.

Left Inverse:

$$AC = I$$

$$C = (A^T A)^{-1} A^T$$

(when rows(A) > columns(A))

Right Inverse:

$$CA = I$$

$$C = A^T (AA^T)^{-1}$$

(when rows(A) < columns(A))

15.6 LINEAR TRANSFORMATION

Axioms for a linear transformation:

If $F(\underline{u} + \underline{v}) = F(\underline{u}) + F(\underline{v})$ [Preserves Addition]

And $F(\lambda \underline{u}) = \lambda F(\underline{u})$ [Preserves Scalar Multiplication]

Transition Matrix:

The matrix that represents the linear transformation

$$T(\underline{v}) = c_1 T(\underline{v}_1) + c_2 T(\underline{v}_2) + \dots + c_n T(\underline{v}_n)$$

$$T(x) = Ax$$

$$A = [T(\underline{e}_1) | T(\underline{e}_2) | \dots | T(\underline{e}_n)] \quad (\text{With } m \text{ columns and } n \text{ rows})$$

$$(T : V \rightarrow W, \dim(V) = m, \dim(W) = n)$$

Zero Transformation:

$$T(\underline{v}) = 0, \forall \underline{v} \in V$$

Identity Transformation:

$$T(\underline{v}) = \underline{v}, \forall \underline{v} \in V$$

15.7 COMMON TRANSITION MATRICES

Rotation (Clockwise):
$$\begin{bmatrix} x' \\ y' \end{bmatrix} = \begin{bmatrix} \cos \theta & \sin \theta \\ -\sin \theta & \cos \theta \end{bmatrix} \begin{bmatrix} x \\ y \end{bmatrix}$$

Rotation (Anticlockwise):
$$\begin{bmatrix} x' \\ y' \end{bmatrix} = \begin{bmatrix} \cos \theta & -\sin \theta \\ \sin \theta & \cos \theta \end{bmatrix} \begin{bmatrix} x \\ y \end{bmatrix}$$

Scaling:
$$\begin{bmatrix} x' \\ y' \end{bmatrix} = \begin{bmatrix} s_x & 0 \\ 0 & s_y \end{bmatrix} \begin{bmatrix} x \\ y \end{bmatrix}$$

Shearing (parallel to x-axis):
$$\begin{bmatrix} x' \\ y' \end{bmatrix} = \begin{bmatrix} 1 & k \\ 0 & 1 \end{bmatrix} \begin{bmatrix} x \\ y \end{bmatrix}$$

Shearing (parallel to y-axis):
$$\begin{bmatrix} x' \\ y' \end{bmatrix} = \begin{bmatrix} 1 & 0 \\ k & 1 \end{bmatrix} \begin{bmatrix} x \\ y \end{bmatrix}$$

15.8 EIGENVALUES AND EIGENVECTORS

Definitions: All solutions of $Ax = \lambda x$

Eigenvalues: All solutions of λ of $\det(A - \lambda I) = 0$

Eigenvectors: General solution of $[A - \lambda I][X] = 0$ (ie: the nullspace)

Characteristic Polynomial: The function $p(\lambda) = \det(A - \lambda I)$

Result 1: Let A be an $n \times n$ matrix and let $p(\lambda)$ be its characteristic polynomial. Suppose that λ is an eigenvalue of A with corresponding eigenvector x . Then:

(i) The leading coefficient of $p(\lambda)$ is $(-1)^n$.

(ii) The constant term of $p(\lambda)$ is $\det(A)$.

(iii) λ^k is an eigenvalue of A^k with corresponding eigenvector x .

(iv) If A is invertible, then $\lambda \neq 0$ and $\frac{1}{\lambda}$ is an eigenvalue of A^{-1} with corresponding eigenvector x .

Algebraic Multiplicity: The number of times a root is repeated for a given eigenvalue.

\sum of all algebraic multiplicity = degree of the characteristic polynomial.

Geometric Multiplicity: The number of linearly independent eigenvectors you get from a given eigenvalue.

Transformation: $T: V \rightarrow V$
 $T(x) = \lambda x$

Linearly Independence: The same process for an ordinary matrix is used. The set of eigenvectors for distinct eigenvalues is linearly independent.

Digitalization: For a $n \times n$ matrix with n distinct eigenvalues; if and only if there are n Linearly Independent Eigenvectors:

$$D = P^{-1}AP$$

Where $P = [P_1 | P_2 | \dots | P_n]$, P_n is an eigenvector.

$$D = \begin{bmatrix} \lambda_1 & 0 & 0 & \dots & 0 \\ 0 & \lambda_2 & 0 & \dots & 0 \\ 0 & 0 & \lambda_3 & \dots & 0 \\ \dots & \dots & \dots & \dots & 0 \\ 0 & 0 & 0 & 0 & \lambda_n \end{bmatrix}$$

Result 7: If $B = C^{-1}AC$, then

- (i) the eigenvalues of B are the same as those of A .
- (ii) each eigenvalue of A or B has the same algebraic and geometric multiplicity, regardless of which matrix they correspond to.
- (iii) if x is an eigenvector of A corresponding to an eigenvalue λ , then $C^{-1}x$ is an eigenvector of B corresponding to λ .

Cayley-Hamilton Theorem: Every matrix satisfies its own polynomial:

$$P(\lambda) = a_n \lambda^n + a_{n-1} \lambda^{n-1} \dots + a_1 \lambda + a_0 = 0$$

$$P(A) = a_n A^n + a_{n-1} A^{n-1} \dots + a_1 A + a_0 = 0$$

Orthonormal Set: The orthonormal basis of a matrix A can be found with $P = [P_1 | P_2 | \dots | P_n]$, the orthonormal set will be

$$B = \left\{ \frac{P_1}{\|P_1\|}, \frac{P_2}{\|P_2\|}, \dots, \frac{P_n}{\|P_n\|} \right\}$$

QR Factorisation:

$$A = [u_1 | u_2 | \dots | u_n] = QR$$

$$\dim(A) = n \times k, k \leq n$$

All columns are Linearly Independent

$$Q = [v_1 | v_2 | \dots | v_n] \text{ by the Gram-Schmidt Process}$$

$$R = \begin{bmatrix} \|q_1\| & u_2^T v_1 & u_3^T v_1 & u_4^T v_1 & \dots & u_k^T v_1 \\ 0 & \|q_2\| & u_3^T v_2 & u_4^T v_2 & \dots & u_k^T v_2 \\ 0 & 0 & \|q_3\| & u_4^T v_3 & \dots & u_k^T v_3 \\ 0 & 0 & 0 & \|q_4\| & \dots & u_k^T v_4 \\ \dots & \dots & \dots & \dots & \dots & \dots \\ 0 & 0 & 0 & 0 & \dots & \|q_k\| \end{bmatrix}$$

$$R = \begin{bmatrix} \|q_1\| & u_2 \bullet v_1 & u_3 \bullet v_1 & u_4 \bullet v_1 & \dots & u_k \bullet v_1 \\ 0 & \|q_2\| & u_3 \bullet v_2 & u_4 \bullet v_2 & \dots & u_k \bullet v_2 \\ 0 & 0 & \|q_3\| & u_4 \bullet v_3 & \dots & u_k \bullet v_3 \\ 0 & 0 & 0 & \|q_4\| & \dots & u_k \bullet v_4 \\ \dots & \dots & \dots & \dots & \dots & \dots \\ 0 & 0 & 0 & 0 & \dots & \|q_k\| \end{bmatrix}$$

15.9 JORDAN FORMS

Generalised Diagonalisation:

$$P^{-1}AP = J$$

$$A = PJP^{-1}$$

Jordan Block:

$$J_B = \begin{bmatrix} \lambda & 1 & 0 & \dots & 0 & 0 \\ 0 & \lambda & 1 & \dots & 0 & 0 \\ 0 & 0 & \lambda & \dots & 0 & 0 \\ \dots & \dots & \dots & \dots & \dots & \dots \\ 0 & 0 & 0 & \dots & \lambda & 1 \\ 0 & 0 & 0 & \dots & 0 & \lambda \end{bmatrix}$$

Jordan Form:

$$J = \begin{bmatrix} J_1 & 0 & \dots & 0 \\ 0 & J_2 & \dots & 0 \\ \dots & \dots & \dots & \dots \\ 0 & 0 & \dots & J_n \end{bmatrix}$$

Algebraic Multiplicity:

Geometric Multiplicity:

Generalised Chain:

The number of times λ appears on main diagonal
The number of times λ appears on main diagonal without a 1 directly above it

$= \{u_m, u_{m-1}, \dots, u_2, u_1\}$, where u_1 is an eigenvector

$$u_k = (A - \lambda I)u_{k+1}$$

$$u_{k+1} = [A - \lambda I | u_k]$$

$P = [P_1 | P_2 | \dots | P_m | \dots]$, for every eigenvector of A

Powers:

$$A^k = PJ^kP^{-1}$$
$$J^k = \begin{bmatrix} J_1 & 0 & \dots & 0 \\ 0 & J_2 & \dots & 0 \\ \dots & \dots & \dots & \dots \\ 0 & 0 & \dots & J_n \end{bmatrix}^k = \begin{bmatrix} J_1^k & 0 & \dots & 0 \\ 0 & J_2^k & \dots & 0 \\ \dots & \dots & \dots & \dots \\ 0 & 0 & \dots & J_n^k \end{bmatrix}$$
$$J_B^k = \begin{bmatrix} \lambda^k & \binom{k}{1} \lambda^{k-1} & \binom{k}{2} \lambda^{k-2} & \dots \\ 0 & \lambda^k & \binom{k}{1} \lambda^{k-1} & \dots \\ 0 & 0 & \lambda^k & \dots \\ \dots & \dots & \dots & \dots \end{bmatrix}$$

15.10 COMPLEX MATRICIS:

Conjugate Transpose:

$$A^* = \overline{A^T}$$

$$A^{**} = A$$

$$(A+B)^* = A^* + B^*$$

$$(zA)^* = \bar{z}A^*$$

$$(AB)^* = B^*A^*$$

Hermitian Matrix: (Similar to Symmetric Matricis in the real case)

A square matrix such that $A^* = A$

Eigenvalues of A are purely real

Eigenvectors from distinct eigenvalues are orthogonal. This leads to a unitary diagonalisation of the Hermitian matrix.

These are normal

Skew-Hermitian:

A square matrix such that $A^* = -A$

Eigenvalues of A are purely imaginary

Eigenvectors from distinct eigenvalues are orthogonal.

If A is Skew-Hermitian, iA is normal as: $(iA)^* = \bar{i}A^* = (-i)(-A) = iA$

These are normal

Unitary Matrix:

(Similar to Orthogonal Matricis in the real case)

A square matrix such that $A^*A = I$

Columns of A form an orthonormal set of vectors

Rows of A form an orthonormal set of vectors

Normal Matrix:

Where $AA^* = A^*A$

These will have unitary diagonalisation

All Hermitian and Skew-Hermitian matricis are normal ($A^*A = AA^* = AA^*$)

Diagonalisation:

For a $n \times n$ matrix with n distinct eigenvalues; if and only if there are n Linearly Independent Eigenvectors:

$$D = P^{-1}AP$$

Where $P = [P_1 | P_2 | \dots | P_n]$, P_n is an eigenvector.

$$D = \begin{bmatrix} \lambda_1 & 0 & 0 & \dots & 0 \\ 0 & \lambda_2 & 0 & \dots & 0 \\ 0 & 0 & \lambda_3 & \dots & 0 \\ \dots & \dots & \dots & \dots & \dots \\ 0 & 0 & 0 & 0 & \lambda_n \end{bmatrix}$$

If A is Hermitian, $D = P^{-1}AP = P^*AP$ as P are an orthonormal set of vectors.

Spectral Theorem:

For a $n \times n$ Normal matrix and eigenvectors form an orthonormal set

$$P = [P_1 | P_2 | \dots | P_n]$$

$$A = \lambda_1 P_1 P_1^* + \lambda_2 P_2 P_2^* + \dots + \lambda_n P_n P_n^*$$

Therefore, A can be represented as a sum of n matrices, all of rank 1.

Therefore, A can be approximated as a sum of the dominant eigenvalues

15.11 NUMERICAL COMPUTATIONS:

Rayleigh Quotient:

$$R(\mathbf{x}) = \frac{\mathbf{x}^T A \mathbf{x}}{\mathbf{x}^T \mathbf{x}}$$

if (λ, \mathbf{v}) is an eigenvalue/eigenvector pair of A , then

$$R(\mathbf{v}) = \frac{\mathbf{v}^T A \mathbf{v}}{\mathbf{v}^T \mathbf{v}} = \frac{\mathbf{v}^T (\lambda \mathbf{v})}{\mathbf{v}^T \mathbf{v}} = \lambda \frac{\mathbf{v}^T \mathbf{v}}{\mathbf{v}^T \mathbf{v}} = \lambda,$$

In particular, suppose that A is a symmetric matrix. Then we know that A can be orthogonally diagonalized, *i.e.* there exists an orthogonal matrix Q such that

$$Q^T A Q = D = \text{diag}(\lambda_1, \lambda_2, \dots, \lambda_n),$$

where $\lambda_1, \lambda_2, \dots, \lambda_n$ are the (real) eigenvalues of A . Now, without loss of generality, suppose that λ_1 is the largest of all the eigenvalues, *i.e.* $\lambda_1 \geq \lambda_i$, for all $i = 2, 3, \dots, n$.

Let \mathbf{x} be any vector in \mathbb{R}^n and let $\mathbf{s} = Q^T \mathbf{x} = \begin{bmatrix} s_1 \\ s_2 \\ \vdots \\ s_n \end{bmatrix} \in \mathbb{R}^n$, so that $\mathbf{x} = Q\mathbf{s}$. Then

$$R(\mathbf{x}) = \frac{\mathbf{x}^T A \mathbf{x}}{\mathbf{x}^T \mathbf{x}} = \frac{\mathbf{s}^T Q^T A Q \mathbf{s}}{\mathbf{s}^T Q^T Q \mathbf{s}} = \frac{\mathbf{s}^T D \mathbf{s}}{\mathbf{s}^T \mathbf{s}} = \frac{\lambda_1 s_1^2 + \lambda_2 s_2^2 + \dots + \lambda_n s_n^2}{s_1^2 + s_2^2 + \dots + s_n^2}.$$

Since λ_1 is the largest eigenvalue,

$$R(\mathbf{x}) \leq \frac{\lambda_1 s_1^2 + \lambda_1 s_2^2 + \dots + \lambda_1 s_n^2}{s_1^2 + s_2^2 + \dots + s_n^2}, \quad \text{i.e. } R(\mathbf{x}) \leq \lambda_1, \text{ for all } \mathbf{x} \in \mathbb{R}^n.$$

i.e. For a real symmetric matrix, the maximum value of Rayleigh's quotient is equal to the largest eigenvalue of A . This fact can sometimes be used to find the largest eigenvalue of a real symmetric matrix. (Note that the above argument is not valid if A is not symmetric.)

Ex 1: Find the largest eigenvalue of $A = \begin{bmatrix} 1 & -2 & 0 \\ -2 & 1 & 0 \\ 0 & 0 & 2 \end{bmatrix}$ and the corresponding eigenvector.

Soln: Let $\mathbf{x} = \begin{bmatrix} x_1 \\ x_2 \\ x_3 \end{bmatrix}$, then

$$\mathbf{x}^T A \mathbf{x} = [x_1 \ x_2 \ x_3] \begin{bmatrix} 1 & -2 & 0 \\ -2 & 1 & 0 \\ 0 & 0 & 2 \end{bmatrix} \begin{bmatrix} x_1 \\ x_2 \\ x_3 \end{bmatrix} = [x_1 \ x_2 \ x_3] \begin{bmatrix} x_1 - 2x_2 \\ -2x_1 + x_2 \\ 2x_3 \end{bmatrix} = x_1^2 - 4x_1x_2 + x_2^2 + 2x_3^2.$$

We have

$$\begin{aligned} R(\mathbf{x}) &= \frac{\mathbf{x}^T A \mathbf{x}}{\mathbf{x}^T \mathbf{x}} \\ &= \frac{x_1^2 - 4x_1x_2 + x_2^2 + 2x_3^2}{x_1^2 + x_2^2 + x_3^2} \\ &= \frac{3x_1^2 + 3x_2^2 - (2x_1^2 + 4x_1x_2 + 2x_2^2) + 2x_3^2}{x_1^2 + x_2^2 + x_3^2} \\ &= \frac{3x_1^2 + 3x_2^2 + 3x_3^2 - 2(x_1 + x_2)^2 - x_3^2}{x_1^2 + x_2^2 + x_3^2} \\ &= 3 - \frac{(2(x_1 + x_2)^2 + x_3^2)}{x_1^2 + x_2^2 + x_3^2} \\ &\leq 3, \end{aligned}$$

for all x_1, x_2 and x_3 . In other words, the maximum eigenvalue is $\lambda = 3$. Note that

$$R(\mathbf{x}) = 3 \text{ only if } x_3 = 0 \text{ and } x_1 + x_2 = 0, \text{ i.e. a corresponding eigenvector is } \mathbf{x} = \begin{bmatrix} -1 \\ 1 \\ 0 \end{bmatrix}$$

Power method:

If A is a $n \times n$ matrix with Linearly Independent Eigenvectors, and distinct eigenvalues arranged such that: $|\lambda_1| \geq |\lambda_2| \geq \dots \geq |\lambda_n|$ and the set of eigenvectors are: $\{v_1, v_2, \dots, v_n\}$

Any vector "w" can be written as:

$$w_0 = c_1 v_1 + c_2 v_2 + \dots + c_n v_n$$

$$w_1 = A w_0 = c_1 A v_1 + c_2 A v_2 + \dots + c_n A v_n = c_1 \lambda_1 v_1 + c_2 \lambda_2 v_2 + \dots + c_n \lambda_n v_n$$

$$w_s = Aw_{s-1} = c_1 \lambda_1^s v_1 + c_2 \lambda_2^s v_2 + \dots + c_n \lambda_n^s v_n = \lambda_1 \left(c_1 v_1 + c_2 \left(\frac{\lambda_2}{\lambda_1} \right)^s v_2 + \dots + c_n \left(\frac{\lambda_n}{\lambda_1} \right)^s v_n \right)$$

$$\text{As } \left| \frac{\lambda_i}{\lambda_1} \right| < 1, \lim_{s \rightarrow \infty} \left(\left(\frac{\lambda_i}{\lambda_1} \right)^s \right) = 0$$

$$\therefore w_s \rightarrow c_1 \lambda_1^s v_1$$

Applying this with the Rayleigh Quotient:

$$w_s = A \left(\frac{w_{s-1}}{|w_{s-1}|} \right), \lambda = R(w_s), w_0 \text{ can be any vector usually } \begin{bmatrix} 1 \\ 0 \\ \dots \end{bmatrix}$$

PART 16: VECTORS

16.1 Basic Operations:

Addition:
$$\underline{a} + \underline{b} = \begin{bmatrix} a_1 + b_1 \\ a_2 + b_2 \\ a_3 + b_3 \end{bmatrix}$$

Subtraction:
$$\underline{a} - \underline{b} = \begin{bmatrix} a_1 - b_1 \\ a_2 - b_2 \\ a_3 - b_3 \end{bmatrix}$$

Equality:
$$\underline{a} = \underline{b} \Leftrightarrow a_1 = b_1, a_2 = b_2, a_3 = b_3$$

$$k\underline{a} + l\underline{b} = \lambda\underline{a} + \mu\underline{b} \Rightarrow k = \lambda, l = \mu$$

Scalar Multiplication:
$$k\underline{a} = \begin{bmatrix} ka_1 \\ ka_2 \\ ka_3 \end{bmatrix}$$

Parallel:
$$\underline{a} = k\underline{b} \Leftrightarrow \underline{a} \parallel \underline{b}$$

Magnitude:
$$|\underline{a}| = \sqrt{(a_1)^2 + (a_2)^2 + (a_3)^2}$$

Unit Vector:
$$\hat{\underline{a}} = \frac{\underline{a}}{|\underline{a}|}$$

Zero Vector: A vector with no magnitude and no specific direction

Dot Product:
$$\underline{a} \bullet \underline{b} = |\underline{a}| \cdot |\underline{b}| \cdot \cos \theta$$

$$\underline{a} \bullet \underline{b} = a_1 b_1 + a_2 b_2 + a_3 b_3$$

Angle Between two Vectors:
$$\cos \theta = \frac{\underline{a} \bullet \underline{b}}{|\underline{a}| \cdot |\underline{b}|}$$

$$\cos \theta = \frac{a_1 b_1 + a_2 b_2 + a_3 b_3}{\left(\sqrt{a_1^2 + a_2^2 + a_3^2}\right) \cdot \left(\sqrt{b_1^2 + b_2^2 + b_3^2}\right)}$$

Angle of a vector in 3D:
$$\hat{\underline{a}} = \begin{bmatrix} \frac{a_1}{|\underline{a}|} \\ \frac{a_2}{|\underline{a}|} \\ \frac{a_3}{|\underline{a}|} \end{bmatrix} = \begin{bmatrix} \cos(\alpha) \\ \cos(\beta) \\ \cos(\gamma) \end{bmatrix}$$

Perpendicular Test:
$$\underline{a} \bullet \underline{b} = 0$$

Scalar Projection: a onto b: $P = \underline{a} \cdot \hat{\underline{b}}$

Vector Projection: a onto b: $\underline{P} = \left(\underline{a} \cdot \hat{\underline{b}} \right) \hat{\underline{b}} = \frac{1}{|\underline{b}|^2} (\underline{a} \cdot \underline{b}) \underline{b}$

Cross Product:

$$\underline{a} \times \underline{b} = \langle a_2 b_3 - a_3 b_2, a_3 b_1 - a_1 b_3, a_1 b_2 - a_2 b_1 \rangle$$

$$\underline{a} \times \underline{b} = |\underline{a}| \cdot |\underline{b}| \cdot \sin \theta \cdot \underline{n}$$

$$|\underline{a} \times \underline{b}| = |\underline{a}| \cdot |\underline{b}| \cdot \sin \theta$$

$$\underline{a} \times \underline{b} = -\underline{b} \times \underline{a}$$

$$\underline{a} \cdot (\underline{b} \times \underline{c}) = \underline{b} \cdot (\underline{c} \times \underline{a}) = \underline{c} \cdot (\underline{a} \times \underline{b})$$

$$\underline{a} \times \underline{b} = \det \begin{bmatrix} \underline{i} & \underline{j} & \underline{k} \\ a_1 & a_2 & a_3 \\ b_1 & b_2 & b_3 \end{bmatrix} = \underline{i} \left(\det \begin{bmatrix} a_2 & a_3 \\ b_2 & b_3 \end{bmatrix} \right) - \underline{j} \left(\det \begin{bmatrix} a_1 & a_3 \\ b_1 & b_3 \end{bmatrix} \right) + \underline{k} \left(\det \begin{bmatrix} a_1 & a_2 \\ b_1 & b_2 \end{bmatrix} \right)$$

16.2 Lines

$\underline{r} = \underline{a} + \lambda \underline{b}$, where a is a point on the line, and b is a vector parallel to the line

$$x = a_1 + \lambda b_1$$

$$y = a_2 + \lambda b_2$$

$$z = a_3 + \lambda b_3$$

$$\lambda = \frac{x - a_1}{b_1} = \frac{y - a_2}{b_2} = \frac{z - a_3}{b_3}$$

16.3 Planes

$$\underline{n} \cdot \overrightarrow{AR} = 0$$

$$\underline{n} \cdot \underline{r} = \underline{n} \cdot \underline{a}$$

$$\underline{n} \cdot \underline{r} = k$$

Where: $\underline{n} = \langle a, b, c \rangle$ & $\underline{r} = \langle x, y, z \rangle$: $ax + by + cz = k$

16.4 Closest Approach

Two Points: $d = |\overline{PQ}|$

Point and Line: $d = \left| \overline{PQ} \times \hat{\underline{a}} \right|$

Point and Plane: $d = \left| \overline{PQ} \cdot \hat{\underline{n}} \right|$

Two Skew Lines:

$$d = \left| \overline{PQ} \cdot \hat{n} \right| = \left| \overline{PQ} \cdot (\underline{a} \times \underline{b}) \right|$$

$$\text{Solving for } t: \begin{cases} [r_b(t) - r_a(t)] \cdot [v_b - v_a] = 0 \\ [r_b(t)] \cdot [v_a] = 0 \end{cases}$$

16.5 Geometry

Area of a Triangle:

$$A = \frac{|AB \times AC|}{2}$$

Area of a Parallelogram:

$$A = |AB \times AC|$$

Area of a Parallelepiped:

$$A = |AD \cdot (AB \times AC)|$$

16.6 Space Curves

Where:

$$r(t) = x(t)i + y(t)j + z(t)k$$

Velocity:

$$v(t) = r'(t) = x'(t)i + y'(t)j + z'(t)k$$

Acceleration:

$$a(t) = v'(t) = r''(t) = x''(t)i + y''(t)j + z''(t)k$$

Definition of "s":

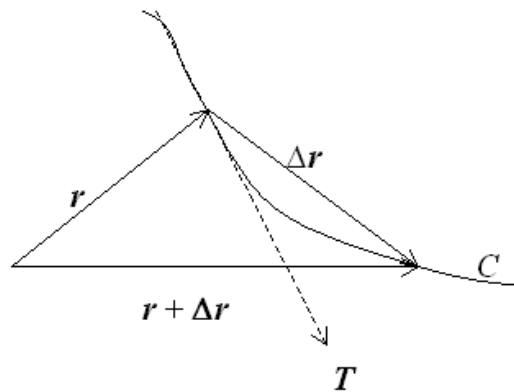

The length of the curve from r to $r + \Delta r$

Unit Tangent:

$$T = \frac{dr}{ds} = \frac{r'(t)}{|r'(t)|}$$

$$|T| = 1$$

Chain Rule:

$$\frac{dr}{dt} = \frac{dr}{ds} \times \frac{ds}{dt}$$

$$\text{As } \left| \frac{dr}{ds} \right| = 1, \left| \frac{dr}{dt} \right| = \left| \frac{ds}{dt} \right| = \text{speed}$$

Normal:

$$T \cdot T = 1$$

$$\frac{d}{ds}(T \cdot T) = 0$$

$$\frac{dT}{ds} \cdot T + T \cdot \frac{dT}{ds} = 0$$

$$2T \cdot \frac{dT}{ds} = 0$$

$$T \cdot \frac{dT}{ds} = 0$$

As T is tangent to the curve, $\frac{dT}{ds}$ is normal

$$N = \frac{\left(\frac{dT}{ds} \right)}{\left| \frac{dT}{ds} \right|}$$

Curvature:

$$\frac{dT}{ds} = \left| \frac{dT}{ds} \right| N = \kappa N$$

$$\therefore \kappa = \left| \frac{dT}{ds} \right| = \frac{|r'(t) \times r''(t)|}{|r'(t)|^3} = \frac{|v(t) \times a(t)|}{|v(t)|^3}$$

Unit Binomial:

$$B = T \times N$$

Tortion:

$$\tau = \left| \frac{dB}{ds} \right|$$

16.7 Vector Space

16.8 ABBREVIATIONS

λ = a scalar value

μ = a scalar value

θ = the angle between the vectors

\underline{a} = a vector

\underline{b} = a vector

k = a scalar value

l = a scalar value

\underline{n} = the normal vector

\underline{r} = the resultant vector

PART 17: SERIES

17.1 MISCELLANEOUS

General Form: $S_n = a_1 + a_2 + a_2 + a_4 + \dots + a_n = \sum_{n=1}^n a_n$

Infinite Form: $S_\infty = a_1 + a_2 + a_2 + a_4 + \dots = \sum_{n=1}^{\infty} a_n$

Partial Sum of a Series: $S_i = a_1 + a_2 + a_2 + a_4 + \dots + a_i = \sum_{n=1}^i a_n$

17.2 TEST FOR CONVERGENCE AND DIVERGENCE

Test For Convergence: $\lim_{n \rightarrow \infty} (S_n) = L$, if L exists, it is convergent

Test For Divergence: $\lim_{n \rightarrow \infty} (a_n) \neq 0$

Geometric Series

$$\sum_{n=1}^{\infty} ar^{n-1} \begin{cases} \text{Divergent, } |r| \geq 1 \\ \text{Convergent, } |r| < 1 \end{cases}$$

P Series

$$\sum_{n=1}^{\infty} \frac{1}{x^p} \begin{cases} \text{Divergent, } p \leq 1 \\ \text{Convergent, } p > 1 \end{cases}$$

The Sandwich Theorem

If there is a positive series so that $a_n \leq b_n \leq c_n$

$$\text{If } \lim_{n \rightarrow \infty} (a_n) = \lim_{n \rightarrow \infty} (c_n) = L, \text{ then, } \lim_{n \rightarrow \infty} (b_n) = L$$

Hence, if a_n & c_n are convergent, b_n must also be convergent

The Integral Test

If $a_n = f(x)$ if $f(x)$ is continuous, positive and decreasing

If S_∞ or $\int_1^{\infty} f(x) dx$ is true, then the other is true

$$a_n = \frac{1}{n} = f(n) = \frac{1}{x} = f(x)$$

Eg:

$$\therefore \int_1^{\infty} f(x) dx = \int_1^{\infty} \frac{1}{x} dx = [\ln x]_1^{\infty} = D.N.E.$$

$\therefore a_n$ is divergent

The Direct Comparison Test

If we want to test a_n , and know the behaviour of b_n , where a_n is a series with only non-negative terms

If b_n is convergent and $a_n \leq b_n$, then a_n is also convergent

The Limit Comparison Test

If there is a convergent series $\sum_{n=1}^{\infty} c_n$, then if $\lim_{n \rightarrow \infty} \left(\frac{a_n}{c_n} \right) < \infty$, then $\sum_{n=1}^{\infty} a_n$ converges

If there is a divergent series $\sum_{n=1}^{\infty} d_n$, then if $\lim_{n \rightarrow \infty} \left(\frac{a_n}{d_n} \right) > 0$, then $\sum_{n=1}^{\infty} a_n$ diverges

D'Alembert's Ratio Comparison Test

FOR POSITIVE TERMS:

Converges: $\lim_{n \rightarrow \infty} \left(\frac{a_{n+1}}{a_n} \right) < 1$

Diverges: $\lim_{n \rightarrow \infty} \left(\frac{a_{n+1}}{a_n} \right) > 1$

Not enough information: $\lim_{n \rightarrow \infty} \left(\frac{a_{n+1}}{a_n} \right) = 1$

The nth Root Test

For $\sum_{n=1}^{\infty} a_n$ where $a_n \geq 0$, then if $\lim_{n \rightarrow \infty} \sqrt[n]{a_n}$,

Converges: $\lim_{n \rightarrow \infty} \sqrt[n]{a_n} < 1$

Diverges: $\lim_{n \rightarrow \infty} \sqrt[n]{a_n} > 1$

Not enough information: $\lim_{n \rightarrow \infty} \sqrt[n]{a_n} = 1$

Abel's Test:

If $\sum_{n=1}^{\infty} a_n$ is positive and decreasing, and $\sum_{n=1}^{\infty} c_n$ is a convergent series.

Then $\sum_{n=1}^{\infty} a_n \times c_n$ Converges

Negative Terms

If $\sum_{n=1}^{\infty} |a_n|$ converges, then $\sum_{n=1}^{\infty} a_n$ is said to be absolutely convergent

Alternating Series Test

This is the only test for an alternating series in the form $\sum_{n=1}^{\infty} a_n = \sum_{n=1}^{\infty} (-1)^n \times b_n$

Let b_n be the sequence of positive numbers. If $b_{n+1} < b_n$ and $\lim_{n \rightarrow \infty} b_n = 0$, then the series is convergent.

Alternating Series Error

$|R_n| = |S - s_n| \leq b_{n+1}$, where R_n is the error of the partial sum to the nth term.

17.3 ARITHMETIC PROGRESSION:

Definition: $a, a + d, a + 2d, a + 3d, \dots$

Nth Term: $= a + d(n - 1)$

Sum Of The First N Terms: $\sum_{a=1}^n a = \frac{n}{2}(2a + d(n - 1))$

17.4 GEOMETRIC PROGRESSION:

Definition: a, ar, ar^2, ar^3, \dots

Nth Term: $= ar^{n-1}$

Sum Of The First N Terms: $S_n = \sum_{a=1}^n a = \frac{a(1 - r^n)}{1 - r}$

Sum To Infinity: $S_\infty = \lim_{n \rightarrow \infty} \left(\frac{a(1 - r^n)}{1 - r} \right) = \frac{a}{1 - r}$ (given $|r| < 1$)

P, A, Q, \dots

Geometric Mean: $\frac{A}{P} = r, \frac{Q}{A} = r$

$$\therefore \frac{A}{P} = \frac{Q}{A} \Rightarrow A^2 = PQ \Rightarrow A = \sqrt{PQ}$$

17.5 SUMMATION SERIES

Linear: $1 + 2 + 3 + 4 + \dots$ $\sum_{a=1}^n a = \frac{n(n+1)}{2}$

Quadratic: $1^2 + 2^2 + 3^2 + 4^2 + \dots$ $\sum_{a=1}^n a^2 = \frac{n(n+1)(2n+1)}{6}$

Cubic: $1^3 + 2^3 + 3^3 + 4^3 + \dots$ $\sum_{a=1}^n a^3 = \left(\frac{n(n+1)}{2} \right)^2$

17.6 APPROXIMATION SERIES

Taylor Series

$$f_{(x)} = \sum_{n=0}^{\infty} a_n (x - x_0)^n = \sum_{n=0}^{\infty} \frac{f^{(n)}(x_0)}{n!} (x - x_0)^n = a_0 + a_1(x - x_0) + a_2(x - x_0)^2 + a_3(x - x_0)^3 + \dots$$

where, $a_n = \frac{f^{(n)}(x_0)}{n!}$

Maclaurin Series

Special case of the Taylor Series where $x_0 = 0$

Linear Approximation:

$$f_{(x)} \approx L_{(x)} = \sum_{n=0}^1 a_n (x - x_0)^n = \sum_{n=0}^1 \frac{f^{(n)}(x_0)}{n!} (x - x_0)^n = a_0 + a_1(x - x_0)$$

Quadratic Approximation:

$$f_{(x)} \approx Q_{(x)} = \sum_{n=0}^2 a_n (x - x_0)^n = \sum_{n=0}^2 \frac{f^{(n)}(x_0)}{n!} (x - x_0)^n = a_0 + a_1(x - x_0) + a_2(x - x_0)^2$$

Cubic Approximation:

$$f_{(x)} \approx C_{(x)} = \sum_{n=0}^3 a_n (x - x_0)^n = \sum_{n=0}^3 \frac{f^{(n)}(x_0)}{n!} (x - x_0)^n = a_0 + a_1(x - x_0) + a_2(x - x_0)^2 + a_3(x - x_0)^3$$

17.7 MONOTONE SERIES

Strictly Increasing: $a_{n+1} > a_n$ $\frac{a_{n+1}}{a_n} > 1$

Non-Decreasing: $a_{n+1} \geq a_n$

Strictly Decreasing: $a_{n+1} < a_n$ $\frac{a_{n+1}}{a_n} < 1$

Non-Increasing: $a_{n+1} \leq a_n$

Convergence: A monotone sequence is convergent if it is bounded, and hence the limit exists when $a_n \rightarrow \infty$

17.8 RIEMANN ZETA FUNCTION

Form:
$$\zeta(n) = \sum_{k=1}^{\infty} \frac{1}{k^n}$$

$$\zeta(2n) = (-1)^{n+1} \frac{B_{2n} (2\pi)^{2n}}{2(2n)!}$$

Euler's Table:

n=2	$\zeta(2) = \sum_{k=1}^{\infty} \frac{1}{k^2} = 1 + \frac{1}{4} + \frac{1}{9} + \dots = \frac{\pi^2}{6}$
n=4	$\zeta(4) = \sum_{k=1}^{\infty} \frac{1}{k^4} = 1 + \frac{1}{16} + \frac{1}{81} + \frac{1}{256} + \dots = \frac{\pi^4}{90}$
n=6	$\zeta(6) = \sum_{k=1}^{\infty} \frac{1}{k^6} = 1 + \frac{1}{64} + \frac{1}{729} + \frac{1}{4096} + \dots = \frac{\pi^6}{945}$
n=8	$\zeta(8) = \frac{\pi^8}{9450}$
n=10	$\zeta(10) = \frac{\pi^{10}}{93555}$

n=12	$\zeta(12) = \frac{691\pi^{12}}{638512875}$
n=14	$\zeta(14) = \frac{2\pi^{14}}{18243225}$
n=16	$\zeta(16) = \frac{3617\pi^{16}}{325641566250}$
n=18	$\zeta(18) = \frac{43867\pi^{18}}{38979295480125}$
n=20	$\zeta(20) = \frac{174611\pi^{20}}{1531329465290625}$
n=22	$\zeta(22) = \frac{155366\pi^{22}}{13447856940643125}$
n=24	$\zeta(24) = \frac{236364091\pi^{24}}{201919571963756521875}$
n=26	$\zeta(26) = \frac{1315862\pi^{26}}{11094481976030578125}$

Alternating Series:

$$\sum_{n=0}^{\infty} \left(\frac{(-1)^n}{2n+1} \right)^1 = \frac{1}{1} - \frac{1}{3} + \frac{1}{5} - \frac{1}{7} + \frac{1}{9} - \dots = \arctan 1 = \frac{\pi}{4}$$

$$\sum_{n=0}^{\infty} \left(\frac{(-1)^n}{2n+1} \right)^2 = \frac{1}{1^2} + \frac{1}{3^2} + \frac{1}{5^2} + \frac{1}{7^2} + \dots = \frac{\pi^2}{8}$$

$$\sum_{n=0}^{\infty} \left(\frac{(-1)^n}{2n+1} \right)^3 = \frac{1}{1^3} - \frac{1}{3^3} + \frac{1}{5^3} - \frac{1}{7^3} + \dots = \frac{\pi^3}{32}$$

$$\sum_{n=0}^{\infty} \left(\frac{(-1)^n}{2n+1} \right)^4 = \frac{1}{1^4} + \frac{1}{3^4} + \frac{1}{5^4} + \frac{1}{7^4} + \dots = \frac{\pi^4}{96}$$

$$\sum_{n=0}^{\infty} \left(\frac{(-1)^n}{2n+1} \right)^5 = \frac{1}{1^5} - \frac{1}{3^5} + \frac{1}{5^5} - \frac{1}{7^5} + \dots = \frac{5\pi^5}{1536}$$

$$\sum_{n=0}^{\infty} \left(\frac{(-1)^n}{2n+1} \right)^6 = \frac{1}{1^6} + \frac{1}{3^6} + \frac{1}{5^6} + \frac{1}{7^6} + \dots = \frac{\pi^6}{960}$$

Proof for n=2:

Taylor Series Expansion: $\sin(x) = x - \frac{x^3}{3!} + \frac{x^5}{5!} - \frac{x^7}{7!} + \dots$

$$\sin(x) = x(x - \pi)(x + \pi)(x - 2\pi)(x + 2\pi) \dots$$

Polynomial Expansion: $\sin(x) = x(x^2 - \pi^2)(x^2 - 4\pi^2)(x^2 - 9\pi^2) \dots$

$$\sin(x) = Ax \left(1 - \frac{x^2}{\pi^2} \right) \left(1 - \frac{x^2}{2^2\pi^2} \right) \left(1 - \frac{x^2}{3^2\pi^2} \right) \dots$$

$$\lim_{x \rightarrow 0} \left(\frac{\sin(x)}{x} \right) = 1 = A$$

$$x - \frac{x^3}{3!} + \frac{x^5}{5!} - \frac{x^7}{7!} + \dots = x \left(1 - \frac{x^2}{\pi^2} \right) \left(1 - \frac{x^2}{2^2 \pi^2} \right) \left(1 - \frac{x^2}{3^2 \pi^2} \right) \dots$$

$$-\frac{1}{3!} = -\frac{1}{\pi^2} - \frac{1}{2^2 \pi^2} - \frac{1}{3^2 \pi^2} - \frac{1}{4^2 \pi^2} \dots$$

Comparing the Coefficient of x^3 :

$$\frac{\pi^2}{6} = 1 + \frac{1}{2^2} + \frac{1}{3^2} + \frac{1}{4^2} \dots$$

17.9 SUMMATIONS OF POLYNOMIAL EXPRESSIONS

$$\sum_{i=m}^n 1 = n + 1 - m$$

$$\sum_{i=1}^n \frac{1}{i} = H_n$$

(Harmonic number)

$$\sum_{i=m}^n i = \frac{(n+1-m)(n+m)}{2}$$

$$\sum_{i=0}^n i = \sum_{i=1}^n i = \frac{n(n+1)}{2} \sum_{i=0}^n i^2 = \frac{n(n+1)(2n+1)}{6} = \frac{n^3}{3} + \frac{n^2}{2} + \frac{n}{6}$$

$$\sum_{i=0}^n i^3 = \left(\frac{n(n+1)}{2} \right)^2 = \frac{n^4}{4} + \frac{n^3}{2} + \frac{n^2}{4} = \left[\sum_{i=1}^n i \right]^2$$

$$\sum_{i=0}^n i^4 = \frac{n(n+1)(2n+1)(3n^2+3n-1)}{30} = \frac{n^5}{5} + \frac{n^4}{2} + \frac{n^3}{3} - \frac{n}{30}$$

$$\sum_{i=0}^n i^p = \frac{(n+1)^{p+1}}{p+1} + \sum_{k=1}^p \frac{B_k}{p-k+1} \binom{p}{k} (n+1)^{p-k+1}$$

where B_k denotes a

Bernoulli number

$$\left(\sum_{i=m}^n i \right)^2 = \sum_{i=m}^n (i^3 - im(m-1))$$

$$\sum_{i=m}^n i^3 = \left(\sum_{i=m}^n i \right)^2 + \sum_{i=m}^n i$$

17.10 SUMMATIONS INVOLVING EXPONENTIAL TERMS

Where $x \neq 1$

$$\sum_{i=m}^{n-1} x^i = \frac{x^m - x^n}{1-x} \quad (m < n)$$

$$\sum_{i=0}^{n-1} x^i = \frac{1-x^n}{1-x} \text{ (geometric series starting at 1)}$$

$$\sum_{i=0}^{n-1} ix^i = \frac{x-nx^n+(n-1)x^{n+1}}{(1-x)^2}$$

$$\sum_{i=0}^{n-1} i2^i = 2+(n-2)2^n \text{ (special case when } x=2)$$

$$\sum_{i=0}^{n-1} \frac{i}{2^i} = 2 - \frac{n+1}{2^{n-1}} \text{ (special case when } x=1/2)$$

$$\sum_{k=0}^{\infty} \frac{z^k}{k!} = e^z$$

$$\sum_{k=0}^{\infty} k \frac{z^k}{k!} = ze^z$$

$$\sum_{k=0}^{\infty} k^2 \frac{z^k}{k!} = (z+z^2)e^z$$

$$\sum_{k=0}^{\infty} k^3 \frac{z^k}{k!} = (z+3z^2+z^3)e^z$$

$$\sum_{k=0}^{\infty} k^4 \frac{z^k}{k!} = (z+7z^2+6z^3+z^4)e^z$$

$$\sum_{k=0}^{\infty} k^n \frac{z^k}{k!} = z \frac{d}{dz} \sum_{k=0}^{\infty} k^{n-1} \frac{z^k}{k!} = e^z T_n(z)$$

where $T_n(z)$ is the Touchard polynomials.

17.11 SUMMATIONS INVOLVING TRIGONOMETRIC TERMS

$$\sum_{k=0}^{\infty} \frac{(-1)^k z^{2k+1}}{(2k+1)!} = \sin z$$

$$\sum_{k=0}^{\infty} \frac{z^{2k+1}}{(2k+1)!} = \sinh z$$

$$\sum_{k=0}^{\infty} \frac{(-1)^k z^{2k}}{(2k)!} = \cos z$$

$$\sum_{k=0}^{\infty} \frac{z^{2k}}{(2k)!} = \cosh z$$

$$\sum_{k=1}^{\infty} \frac{(-1)^{k-1} (2^{2k}-1) 2^{2k} B_{2k} z^{2k-1}}{(2k)!} = \tan z, |z| < \frac{\pi}{2}$$

$$\sum_{k=1}^{\infty} \frac{(2^{2k}-1) 2^{2k} B_{2k} z^{2k-1}}{(2k)!} = \tanh z, |z| < \frac{\pi}{2}$$

$$\sum_{k=0}^{\infty} \frac{(-1)^k 2^{2k} B_{2k} z^{2k-1}}{(2k)!} = \cot z, |z| < \pi$$

$$\sum_{k=0}^{\infty} \frac{2^{2k} B_{2k} z^{2k-1}}{(2k)!} = \coth z, |z| < \pi$$

$$\sum_{k=0}^{\infty} \frac{(-1)^{k-1} (2^{2k} - 2) B_{2k} z^{2k-1}}{(2k)!} = \csc z, |z| < \pi$$

$$\sum_{k=0}^{\infty} \frac{-(2^{2k} - 2) B_{2k} z^{2k-1}}{(2k)!} = \operatorname{csch} z, |z| < \pi$$

$$\sum_{k=0}^{\infty} \frac{(-1)^k E_{2k} z^{2k}}{(2k)!} = \sec z, |z| < \frac{\pi}{2}$$

$$\sum_{k=0}^{\infty} \frac{E_{2k} z^{2k}}{(2k)!} = \operatorname{sech} z, |z| < \frac{\pi}{2}$$

$$\sum_{k=0}^{\infty} \frac{(2k)! z^{2k+1}}{2^{2k} (k!)^2 (2k+1)} = \arcsin z, |z| \leq 1$$

$$\sum_{k=0}^{\infty} \frac{(-1)^k (2k)! z^{2k+1}}{2^{2k} (k!)^2 (2k+1)} = \operatorname{arsinh} z, |z| \leq 1$$

$$\sum_{k=0}^{\infty} \frac{(-1)^k z^{2k+1}}{2k+1} = \arctan z, |z| < 1$$

$$\sum_{k=0}^{\infty} \frac{z^{2k+1}}{2k+1} = \operatorname{artanh} z, |z| < 1$$

$$\ln 2 + \sum_{k=1}^{\infty} \frac{(-1)^{k-1} (2k)! z^{2k}}{2^{2k+1} k (k!)^2} = \ln(1 + \sqrt{1 + z^2}), |z| \leq 1$$

$$\sum_{k=1}^{\infty} \frac{\sin(k\theta)}{k} = \frac{\pi - \theta}{2}, 0 < \theta < 2\pi$$

$$\sum_{k=1}^{\infty} \frac{\cos(k\theta)}{k} = -\frac{1}{2} \ln(2 - 2 \cos \theta), \theta \in \mathbb{R}$$

$$\sum_{k=0}^{\infty} \frac{\sin[(2k+1)\theta]}{2k+1} = \frac{\pi}{4}, 0 < \theta < \pi$$

$$B_n(x) = -\frac{n!}{2^{n-1} \pi^n} \sum_{k=1}^{\infty} \frac{1}{k^n} \cos\left(2\pi kx - \frac{\pi n}{2}\right), 0 < x < 1$$

$$\sum_{k=0}^n \sin(\theta + k\alpha) = \frac{\sin \frac{(n+1)\alpha}{2} \sin(\theta + \frac{n\alpha}{2})}{\sin \frac{\alpha}{2}}$$

$$\sum_{k=1}^{n-1} \sin \frac{\pi k}{n} = \cot \frac{\pi}{2n}$$

$$\sum_{k=0}^{n-1} \csc^2\left(\theta + \frac{\pi k}{n}\right) = n^2 \csc^2(n\theta) \sum_{k=1}^{n-1} \csc^2 \frac{\pi k}{n} = \frac{n^2 - 1}{3}$$

$$\sum_{k=1}^{n-1} \csc^4 \frac{\pi k}{n} = \frac{n^4 + 10n^2 - 11}{45}$$

17.12 INFINITE SUMMATIONS TO PI

$$\pi = \frac{1}{Z} \quad Z = \sum_{n=0}^{\infty} \frac{((2n)!)^3(42n + 5)}{(n!)^6 16^{3n+1}}$$

$$\pi = \frac{4}{Z} \quad Z = \sum_{n=0}^{\infty} \frac{(-1)^n (4n)! (21460n + 1123)}{(n!)^4 441^{2n+1} 2^{10n+1}}$$

$$\pi = \frac{4}{Z} \quad Z = \sum_{n=0}^{\infty} \frac{(6n + 1) \left(\frac{1}{2}\right)_n^3}{4^n (n!)^3}$$

$$\pi = \frac{72}{Z} \quad Z = \sum_{n=0}^{\infty} \frac{(-1)^n (4n)! (260n + 23)}{(n!)^4 4^{4n} 18^{2n}}$$

$$\pi = \frac{3528}{Z} \quad Z = \sum_{n=0}^{\infty} \frac{(-1)^n (4n)! (21460n + 1123)}{(n!)^4 4^{4n} 882^{2n}}$$

17.13 LIMITS INVOLVING TRIGONOMETRIC TERMS

$$\lim_{x \rightarrow a} \sin x = \sin a$$

$$\lim_{x \rightarrow a} \cos x = \cos a$$

$$\lim_{x \rightarrow 0} \frac{\sin x}{x} = 1$$

$$\lim_{x \rightarrow 0} \frac{1 - \cos x}{x} = 0$$

$$\lim_{x \rightarrow 0} \frac{1 - \cos x}{x^2} = \frac{1}{2}$$

$$\lim_{x \rightarrow n\pi} \tan \left(\pi x + \frac{\pi}{2} \right) = \mp \infty \quad \text{for any integer } n$$

ABBREVIATIONS

a = the first term

d = A.P. difference

r = G.P. ratio

17.14 POWER SERIES EXPANSION

Exponential:

$$\sum_{k=0}^{\infty} \frac{z^k}{k!} = e^z$$

$$\sum_{k=0}^{\infty} k \frac{z^k}{k!} = z e^z$$

$$\sum_{k=0}^{\infty} k^2 \frac{z^k}{k!} = (z + z^2)e^z$$

$$\sum_{k=0}^{\infty} k^3 \frac{z^k}{k!} = (z + 3z^2 + z^3)e^z$$

$$\sum_{k=0}^{\infty} k^4 \frac{z^k}{k!} = (z + 7z^2 + 6z^3 + z^4)e^z$$

$$\sum_{k=0}^{\infty} k^n \frac{z^k}{k!} = z \frac{d}{dz} \sum_{k=0}^{\infty} k^{n-1} \frac{z^k}{k!} = e^z T_n(z)$$

$$\ln 2 + \sum_{k=1}^{\infty} \frac{(-1)^{k-1} (2k)! z^{2k}}{2^{2k+1} k (k!)^2} = \ln(1 + \sqrt{1 + z^2}), |z| \leq 1$$

Trigonometric:

$$\sin x = x - \frac{x^3}{3!} + \frac{x^5}{5!} - \frac{x^7}{7!} + \dots$$

$$= \sum_{n=0}^{\infty} \frac{(-1)^n x^{2n+1}}{(2n+1)!},$$

$$\cos x = 1 - \frac{x^2}{2!} + \frac{x^4}{4!} - \frac{x^6}{6!} + \dots$$

$$= \sum_{n=0}^{\infty} \frac{(-1)^n x^{2n}}{(2n)!}.$$

$$\tan x = \sum_{n=0}^{\infty} \frac{U_{2n+1} x^{2n+1}}{(2n+1)!}$$

$$= \sum_{n=1}^{\infty} \frac{(-1)^{n-1} 2^{2n} (2^{2n} - 1) B_{2n} x^{2n-1}}{(2n)!}$$

$$= x + \frac{1}{3}x^3 + \frac{2}{15}x^5 + \frac{17}{315}x^7 + \dots, \quad \text{for } |x| < \frac{\pi}{2}.$$

$$\csc x = \sum_{n=0}^{\infty} \frac{(-1)^{n+1} 2(2^{2n-1} - 1) B_{2n} x^{2n-1}}{(2n)!}$$

$$= x^{-1} + \frac{1}{6}x + \frac{7}{360}x^3 + \frac{31}{15120}x^5 + \dots, \quad \text{for } 0 < |x| < \pi.$$

$$\sec x = \sum_{n=0}^{\infty} \frac{U_{2n} x^{2n}}{(2n)!} = \sum_{n=0}^{\infty} \frac{(-1)^n E_{2n} x^{2n}}{(2n)!}$$

$$= 1 + \frac{1}{2}x^2 + \frac{5}{24}x^4 + \frac{61}{720}x^6 + \dots, \quad \text{for } |x| < \frac{\pi}{2}.$$

$$\cot x = \sum_{n=0}^{\infty} \frac{(-1)^n 2^{2n} B_{2n} x^{2n-1}}{(2n)!}$$

$$= x^{-1} - \frac{1}{3}x - \frac{1}{45}x^3 - \frac{2}{945}x^5 - \dots, \quad \text{for } 0 < |x| < \pi.$$

$$\sum_{k=0}^{\infty} \frac{z^{2k+1}}{(2k+1)!} = \sinh z$$

$$\sum_{k=0}^{\infty} \frac{z^{2k}}{(2k)!} = \cosh z$$

$$\sum_{k=1}^{\infty} \frac{(2^{2k} - 1) 2^{2k} B_{2k} z^{2k-1}}{(2k)!} = \tanh z, |z| < \frac{\pi}{2}$$

$$\sum_{k=0}^{\infty} \frac{2^{2k} B_{2k} z^{2k-1}}{(2k)!} = \coth z, |z| < \pi$$

$$\sum_{k=0}^{\infty} \frac{-(2^{2k} - 2) B_{2k} z^{2k-1}}{(2k)!} = \operatorname{csch} z, |z| < \pi$$

$$\sum_{k=0}^{\infty} \frac{E_{2k} z^{2k}}{(2k)!} = \operatorname{sech} z, |z| < \frac{\pi}{2}$$

$$\sum_{k=0}^{\infty} \frac{(2k)! z^{2k+1}}{2^{2k} (k!)^2 (2k+1)} = \arcsin z, |z| \leq 1$$

$$\sum_{k=0}^{\infty} \frac{(-1)^k (2k)! z^{2k+1}}{2^{2k} (k!)^2 (2k+1)} = \operatorname{arsinh} z, |z| \leq 1$$

$$\sum_{k=0}^{\infty} \frac{(-1)^k z^{2k+1}}{2k+1} = \arctan z, |z| < 1$$

$$\sum_{k=0}^{\infty} \frac{z^{2k+1}}{2k+1} = \operatorname{artanh} z, |z| < 1$$

$$\sum_{k=1}^{\infty} \frac{\sin(k\theta)}{k} = \frac{\pi - \theta}{2}, 0 < \theta < 2\pi$$

$$\sum_{k=1}^{\infty} \frac{\cos(k\theta)}{k} = -\frac{1}{2} \ln(2 - 2 \cos \theta), \theta \in \mathbb{R}$$

$$\sum_{k=0}^{\infty} \frac{\sin[(2k+1)\theta]}{2k+1} = \frac{\pi}{4}, 0 < \theta < \pi$$

$$B_n(x) = -\frac{n!}{2^{n-1}\pi^n} \sum_{k=1}^{\infty} \frac{1}{k^n} \cos\left(2\pi kx - \frac{\pi n}{2}\right), 0 < x < 1$$

$$\sum_{k=0}^n \sin(\theta + k\alpha) = \frac{\sin \frac{(n+1)\alpha}{2} \sin(\theta + \frac{n\alpha}{2})}{\sin \frac{\alpha}{2}}$$

$$\sum_{k=1}^{n-1} \sin \frac{\pi k}{n} = \cot \frac{\pi}{2n}$$

$$\sum_{k=0}^{n-1} \csc^2\left(\theta + \frac{\pi k}{n}\right) = n^2 \csc^2(n\theta)$$

$$\sum_{k=1}^{n-1} \csc^2 \frac{\pi k}{n} = \frac{n^2 - 1}{3}$$

$$\sum_{k=1}^{n-1} \csc^4 \frac{\pi k}{n} = \frac{n^4 + 10n^2 - 11}{45}$$

$$\sum_{k=0}^{\infty} \frac{2^{2k}(k!)^2}{(k+1)(2k+1)!} z^{2k+2} = (\arcsin z)^2, |z| \leq 1$$

Exponential and Logarithm Series:

$$\ln(1+x) = x \left(\frac{1}{1} - x \left(\frac{1}{2} - x \left(\frac{1}{3} - x \left(\frac{1}{4} - x \left(\frac{1}{5} - \dots \right) \right) \right) \right) \right) \quad \text{for } |x| < 1.$$

$$\begin{aligned} \ln(x) &= \ln\left(\frac{1+y}{1-y}\right) = 2y \left(\frac{1}{1} + \frac{1}{3}y^2 + \frac{1}{5}y^4 + \frac{1}{7}y^6 + \frac{1}{9}y^8 + \dots \right) \\ &= 2y \left(\frac{1}{1} + y^2 \left(\frac{1}{3} + y^2 \left(\frac{1}{5} + y^2 \left(\frac{1}{7} + y^2 \left(\frac{1}{9} + \dots \right) \right) \right) \right) \right), y = \frac{x-1}{x+1} \end{aligned}$$

$$\ln(1+x) = \frac{x^1}{1} - \frac{x^2}{2} + \frac{x^3}{3} - \frac{x^4}{4} + \frac{x^5}{5} - \dots = \frac{x}{1 - 0x + \frac{1^2x}{2 - 1x + \frac{2^2x}{3 - 2x + \frac{3^2x}{4 - 3x + \frac{4^2x}{5 - 4x + \dots}}}}$$

$$\ln\left(1 + \frac{2x}{y}\right) = \frac{2x}{y + \frac{x}{1 + \frac{2x}{3y + \frac{2x}{1 + \frac{2x}{5y + \frac{3x}{1 + \dots}}}}}} = \frac{2x}{y + x - \frac{(1x)^2}{3(y+x) - \frac{(2x)^2}{5(y+x) - \frac{(3x)^2}{7(y+x) - \dots}}}}$$

Fourier Series:

$$f_w(x) = \frac{a_0}{2} + \sum_{k=1}^{\infty} a_k \cos(kx) + b_k \sin(kx)$$

$$f_w(x) = \frac{a_0}{2} + a_1 \cos(x) + a_2 \cos(2x) + \dots + a_n \cos(nx) + b_1 \sin(x) + b_2 \sin(2x) + \dots + b_n \sin(nx)$$

$$a_k = \frac{1}{\pi} \int_0^{2\pi} f(x) \cos(kx) dx \quad k = 0, 1, 2, \dots, n$$

$$b_k = \frac{1}{\pi} \int_0^{2\pi} f(x) \sin(kx) dx \quad k = 1, 2, \dots, n$$

17.15 Bernoulli Expansion:

Fundamentally:

$$1^k + 2^k + 3^k + \dots + n^k = \begin{cases} \text{A polynomial in } n(n+1) & k \text{ odd} \\ (2n+1) \times \text{A polynomial in } n(n+1) & k \text{ even} \end{cases}$$

Expansions:

$$1+2+3+\dots+n = \frac{1}{2}n(n+1)$$

$$1+2+3+\dots+n = \frac{1}{2}n^2 + \frac{1}{2}n$$

$$1+2+3+\dots+n = \frac{1}{2} \left(\binom{2}{0} B_0 n^2 + \binom{2}{1} B_1 n \right)$$

$$1^2+2^2+3^2+\dots+n^2 = (2n+1) \frac{1}{6} n(n+1)$$

$$1^2+2^2+3^2+\dots+n^2 = \frac{1}{3}n^3 + \frac{1}{2}n^2 + \frac{1}{6}n$$

$$1^2+2^2+3^2+\dots+n^2 = \frac{1}{3} \left(\binom{3}{0} B_0 n^3 + \binom{3}{1} B_1 n^2 + \binom{3}{2} B_2 n \right)$$

$$1^3+2^3+3^3+\dots+n^3 = (1+2+3+\dots+n)^2$$

$$1^3+2^3+3^3+\dots+n^3 = \frac{1}{4}(n(n+1))^2$$

$$1^3+2^3+3^3+\dots+n^3 = \frac{1}{4}n^4 + \frac{1}{2}n^3 + \frac{1}{4}n^2$$

$$1^3+2^3+3^3+\dots+n^3 = \frac{1}{4} \left(\binom{4}{0} B_0 n^4 + \binom{4}{1} B_1 n^3 + \binom{4}{2} B_2 n^2 + \binom{4}{3} B_3 n \right)$$

$$1^4+2^4+3^4+\dots+n^4 = (2n+1) \frac{1}{30} n(n+1)(3n(n+1)-1)$$

$$1^4+2^4+3^4+\dots+n^4 = \frac{1}{5}n^5 + \frac{1}{2}n^4 + \frac{1}{3}n^3 - \frac{1}{30}n$$

$$1^4+2^4+3^4+\dots+n^4 = \frac{1}{5} \left(\binom{5}{0} B_0 n^5 + \binom{5}{1} B_1 n^4 + \binom{5}{2} B_2 n^3 + \binom{5}{3} B_3 n^2 + \binom{5}{4} B_4 n \right)$$

$$1^k+2^k+3^k+\dots+n^k = \frac{1}{k+1} \left(\binom{k+1}{0} B_0 n^{k+1} + \binom{k+1}{1} B_1 n^{k+1-1} + \binom{k+1}{2} B_2 n^{k+1-2} + \dots + \binom{k+1}{k-1} B_{k-1} n^2 + \binom{k+1}{k} B_k n \right)$$

List of Bernoulli Numbers:

n	B(n)
0	1
1	$-\frac{1}{2}$
2	$\frac{1}{6}$
3	0

4	$-\frac{1}{30}$
5	0
6	$\frac{1}{42}$
7	0
8	$-\frac{1}{30}$
9	0
10	$\frac{5}{66}$
11	0
12	$-\frac{691}{2730}$
13	0
14	$\frac{7}{6}$
15	0
16	$-\frac{3617}{510}$
17	0
18	$\frac{43867}{798}$
19	0
20	$-\frac{174611}{330}$

PART 18: ELECTRICAL

18.1 FUNDAMENTAL THEORY

Charge: $q = 6.24 \times 10^{18}$ Coulombs

Current: $I = \frac{dq}{dt}$

Resistance: $R = \frac{\rho \ell}{A}$

Ohm's Law: $V = IR$

Power: $P = VI = I^2 R = \frac{V^2}{R}$

Conservation of Power: $\sum P_{CONSUMED} = \sum P_{DELIVERED}$

Electrical Energy: $W = P \times t = I^2 \times R \times t = \int_0^t P dt$

Kirchoff's Voltage Law: The sum of the volt drops around a close loop is equal to zero.

$$\sum V = 0$$

Kirchoff's Current Law: The sum of the currents entering any junction is equal to the sum of the currents leaving that junction.

$$\sum I_{IN} = \sum I_{OUT}$$

Average Current: $I_{AVE} = \frac{1}{T} \int_0^T I(t) dt$

$$I_{AVE} = \frac{1}{T} \times Area \text{ (under } I(t))$$

RMS Current: $\sqrt{\frac{1}{T} \int_0^T (I(t))^2 dt}$

Δ to Y Conversion:

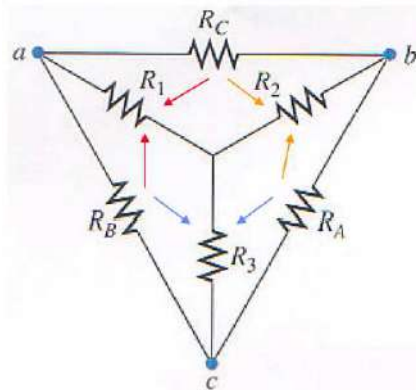

$$R_1 = \frac{R_B R_C}{R_A + R_B + R_C}$$

$$R_2 = \frac{R_A R_C}{R_A + R_B + R_C}$$

$$R_3 = \frac{R_A R_B}{R_A + R_B + R_C}$$

$$R_A = \frac{R_1 R_2 + R_2 R_3 + R_1 R_3}{R_1}$$

$$R_B = \frac{R_1 R_2 + R_2 R_3 + R_1 R_3}{R_2}$$

$$R_C = \frac{R_1 R_2 + R_2 R_3 + R_1 R_3}{R_3}$$

18.2 COMPONENTS

Resistance in Series: $R_T = R_1 + R_2 + R_3 + \dots$

Resistance in Parallel: $\frac{1}{R_T} = \frac{1}{R_1} + \frac{1}{R_2} + \frac{1}{R_3} + \dots$

Inductive Impedance: $X_L = j\omega L = j2\pi fL$

Capacitor Impedance: $X_C = -j \frac{1}{\omega C} = -j \frac{1}{2\pi fC}$

Capacitance in Series: $\frac{1}{C_T} = \frac{1}{C_1} + \frac{1}{C_2} + \frac{1}{C_3} + \dots$

Capacitance in Parallel: $C_T = C_1 + C_2 + C_3 + \dots$

Voltage, Current & Power Summary:

Relation	Resistor (R)	Capacitor (C)	Inductor (L)
$v-i$:	$v = iR$	$v = \frac{1}{C} \int_{t_0}^t i dt + v(t_0)$	$v = L \frac{di}{dt}$
$i-v$:	$i = v/R$	$i = C \frac{dv}{dt}$	$i = \frac{1}{L} \int_{t_0}^t v dt + i(t_0)$
p or w :	$p = i^2 R = \frac{v^2}{R}$	$w = \frac{1}{2} C v^2$	$w = \frac{1}{2} L i^2$
Series:	$R_{eq} = R_1 + R_2$	$C_{eq} = \frac{C_1 C_2}{C_1 + C_2}$	$L_{eq} = L_1 + L_2$
Parallel:	$R_{cq} = \frac{R_1 R_2}{R_1 + R_2}$	$C_{cq} = C_1 + C_2$	$L_{cq} = \frac{L_1 L_2}{L_1 + L_2}$
At dc:	Same	Open circuit	Short circuit
Circuit variable that cannot change abruptly:	Not applicable	v	i

18.3 THEVENIN'S THEOREM

Thevenin's Theorem:

V_{TH} = Open Circuit Voltage between a & b

R_{TH} = Short Circuit any voltage source and Open Circuit any current source and calculate R_{TH} as the resistance from a & b. With dependant sources, SC terminals a & b and calculate the current in the wire

$$(I_{SC}) \cdot R_{TH} = \frac{V_{TH}}{I_{SC}}$$

Maximum Power Transfer Theorem: $P_{MAX} = \frac{(V_{TH})^2}{4R_{TH}}$, where $R_L = R_{TH}$

18.4 FIRST ORDER RC CIRCUIT

18.5 FIRST ORDER RL CIRCUIT

18.6 SECOND ORDER RLC SERIES CIRCUIT

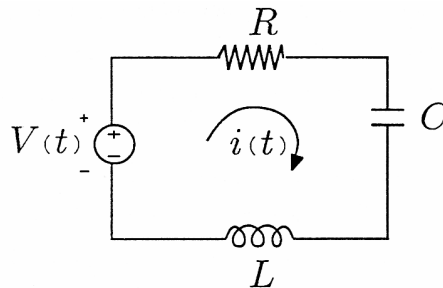

Calculation using KVL:

$$-V_s + V_R + V_L + V_C = 0$$

$$V_R + V_L + V_C = V_s$$

$$Ri + L \frac{di}{dt} + V_C = V_s$$

Circuit current:

$$i = i_C = C \frac{dV_C}{dt}$$

$$\therefore \frac{di}{dt} = C \frac{d^2V_C}{dt^2}$$

$$\therefore RC \frac{dV_C}{dt} + LC \frac{d^2V_C}{dt^2} + V_C = V_s$$

$$LC \frac{d^2V_C}{dt^2} + RC \frac{dV_C}{dt} + V_C = V_s$$

$$\frac{d^2V_C}{dt^2} + \frac{R}{L} \frac{dV_C}{dt} + \frac{1}{LC} V_C = \frac{V_s}{LC}$$

Important Variables

Standard Format: $s^2 + 2\alpha s + \omega_0^2 = 0$

Damping Factor: $\alpha = \frac{1}{2} \left(\frac{R}{L} \right)$

Natural Frequency: $s = \frac{dV_c}{dt}$

Undamped Natural Frequency: $\omega_0 = \sqrt{\left(\frac{1}{LC} \right)}$

Damping Frequency: $\omega_d = \sqrt{\omega_0^2 - \alpha^2}$

Mode Delta: $\Delta = \alpha^2 - \omega_0^2$

V_C : $V_C(t) = \text{TRANSIENT} + \text{FINAL}$

Solving:

$$s^2 + \frac{R}{L}s + \frac{1}{LC} = 0$$

$$s = -\alpha \pm \sqrt{\alpha^2 - \omega_0^2} = -\alpha \pm \sqrt{\Delta}$$

Mode 1:

If: $\Delta > 0$, then :

$$s = -\alpha \pm \sqrt{\Delta}$$

$$V_C(t) = \text{TRANSIENT} + \text{FINAL}$$

$$\text{TRANSIENT} = Ae^{s_1 t} + Be^{s_2 t}$$

$$\text{FINAL} = V_C(\infty) = V_S$$

$$V_C(t) = Ae^{s_1 t} + Be^{s_2 t} + V_S$$

Finding A & B:

$$V_C(0^+) = V_C(0^-) = V_0$$

$$\therefore A + B + V_S = V_0 \rightarrow A + B = V_0 - V_S$$

$$\frac{dV_c}{dt} = As_1 e^{s_1 t} + Bs_2 e^{s_2 t}$$

$$\frac{dV_C(0^+)}{dt} = \frac{i_C(0^+)}{C} = \frac{i_L(0^+)}{C} = \frac{i_L(0^-)}{C} = \frac{I_0}{C} = As_1 + Bs_2$$

$$\left. \begin{aligned} V_0 - V_S &= A + B \\ \therefore \frac{I_0}{C} &= As_1 + Bs_2 \end{aligned} \right\}$$

Mode 2:

If: $\Delta = 0$, then :

$$s = -\alpha$$

$$V_C(t) = \text{TRANSIENT} + \text{FINAL}$$

$$\text{TRANSIENT} = (A + Bt)e^{st} = (A + Bt)e^{-\alpha t}$$

$$\text{FINAL} = V_C(\infty) = V_S$$

$$V_C(t) = (A + Bt)e^{-\alpha t} + V_S$$

Finding A & B:

$$\begin{aligned}
V_C(0^+) &= V_C(0^-) = V_0 \\
\therefore A + V_S &= V_0 \rightarrow A = V_0 - V_S \\
\frac{dV_C}{dt} &= (A + Bt)se^{st} + Be^{st} \\
\frac{dV_C(0^+)}{dt} &= \frac{i_C(0^+)}{C} = \frac{i_L(0^+)}{C} = \frac{i_L(0^-)}{C} = \frac{I_0}{C} = As + B \\
\left. \begin{aligned} V_0 - V_S &= A \\ \therefore \frac{I_0}{C} &= As + B \end{aligned} \right\}
\end{aligned}$$

Mode 3:

If: $\Delta < 0$, and letting $\omega_d = \sqrt{\omega_0^2 - \alpha^2}$, then :

$$s = -\alpha \pm j\omega_d$$

$$V_C(t) = \text{TRANSIENT} + \text{FINAL}$$

$$\text{TRANSIENT} = (A \cos(\omega_d t) + B \sin(\omega_d t))e^{-\alpha t}$$

$$\text{FINAL} = V_C(\infty) = V_S$$

$$V_C(t) = (A \cos(\omega_d t) + B \sin(\omega_d t))e^{-\alpha t} + V_S$$

Finding A & B:

$$V_C(0^+) = V_C(0^-) = V_0$$

$$\therefore A + V_S = V_0 \rightarrow A = V_0 - V_S$$

$$\frac{dV_C}{dt} = (-A\omega_d \sin(\omega_d t) + B\omega_d \cos(\omega_d t))e^{-\alpha t} - \alpha(A \cos(\omega_d t) + B \sin(\omega_d t))e^{-\alpha t}$$

$$\frac{dV_C(0^+)}{dt} = \frac{i_C(0^+)}{C} = \frac{i_L(0^+)}{C} = \frac{i_L(0^-)}{C} = \frac{I_0}{C} = B\omega_d - \alpha A$$

$$\left. \begin{aligned} V_0 - V_S &= A \\ \therefore \frac{I_0}{C} &= B\omega_d - \alpha A \end{aligned} \right\}$$

Mode 4:

If: $R = 0$, then :

$$\alpha = 0, \omega_d = \omega_0$$

$$s = \pm j\omega_d = \pm j\omega_0$$

$$V_C(t) = \text{TRANSIENT} + \text{FINAL}$$

$$\text{TRANSIENT} = A \cos(\omega_d t) + B \sin(\omega_d t)$$

$$\text{FINAL} = V_C(\infty) = V_S$$

$$V_C(t) = A \cos(\omega_d t) + B \sin(\omega_d t) + V_S$$

Finding A & B:

$$V_C(0^+) = V_C(0^-) = V_0$$

$$\therefore A + V_S = V_0 \rightarrow A = V_0 - V_S$$

$$\frac{dV_C}{dt} = -A\omega_d \sin(\omega_d t) + B\omega_d \cos(\omega_d t)$$

$$\frac{dV_C(0^+)}{dt} = \frac{i_C(0^+)}{C} = \frac{i_L(0^+)}{C} = \frac{i_L(0^-)}{C} = \frac{I_0}{C} = B\omega_d$$

$$\left. \begin{aligned} V_0 - V_S = A \\ \therefore \frac{I_0}{C} = B\omega_d \end{aligned} \right\}$$

Current through Inductor:

$$i_L = i_C = C \frac{dV_C}{dt}$$

Plotting Modes:

Mode 1: Over Damped

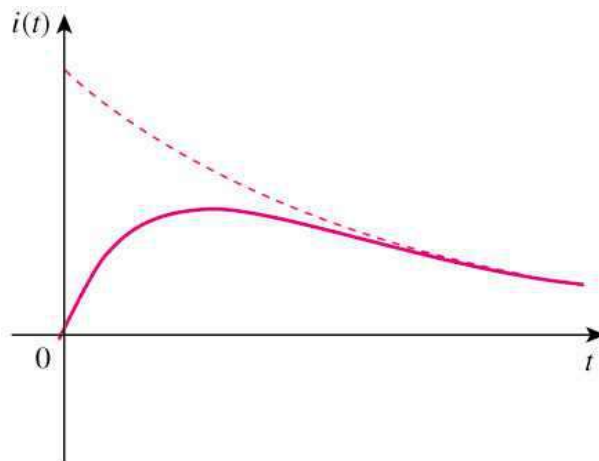

Mode 2: Critically Damped

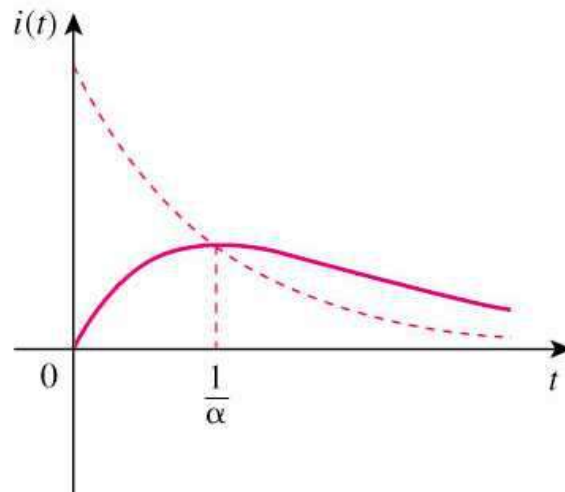

Mode 3: Sinusoidal Damped

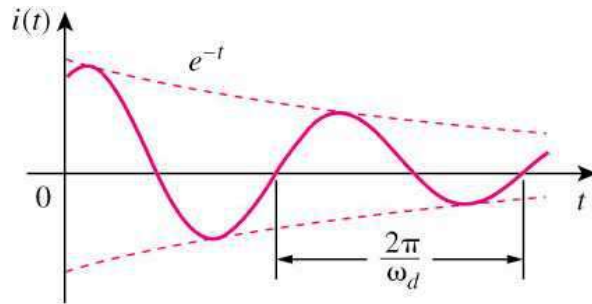

Mode 4: Not Damped
(Oscillates indefinitely)

18.7 SECOND ORDER RLC PARALLEL CIRCUIT

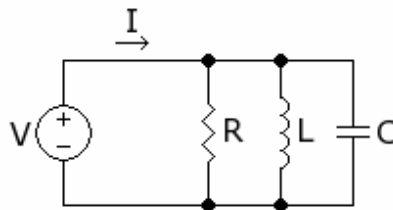

Calculation using KCL:

$$i_s = i_R + i_L + i_C$$

$$i_s = \frac{V}{R} + i_L + C \frac{dV}{dt}$$

Node Voltage:

$$V_L = L \frac{di_L}{dt} = V$$

$$\frac{dV}{dt} = L \frac{d^2 i_L}{dt^2}$$

$$\therefore i_s = \frac{L}{R} \frac{di_L}{dt} + i_L + LC \frac{d^2 i_L}{dt^2}$$

$$LC \frac{d^2 i_L}{dt^2} + \frac{L}{R} \frac{di_L}{dt} + i_L = i_s$$

$$\frac{d^2 i_L}{dt^2} + \frac{1}{RC} \frac{di_L}{dt} + \frac{1}{LC} i_L = \frac{1}{LC} i_s$$

Important Variables

Standard Format: $s^2 + 2\alpha s + \omega_0^2 = 0$

Damping Factor: $\alpha = \frac{1}{2} \left(\frac{1}{RC} \right)$

Undamped Natural Frequency: $\omega_0 = \sqrt{\left(\frac{1}{LC} \right)}$

Damping Frequency: $\omega_d = \sqrt{\omega_0^2 - \alpha^2}$

Mode Delta: $\Delta = \alpha^2 - \omega_0^2$

Solving:

$$s^2 + \frac{1}{RC}s + \frac{1}{LC} = 0$$

$$s = -\alpha \pm \sqrt{\alpha^2 - \omega_0^2} = -\alpha \pm \sqrt{\Delta}$$

18.8 LAPLACE TRANSFORMATIONS

Identities:

$$1. \mathcal{L}\{1\} = \frac{1}{s}, \quad s > 0$$

$$2. \mathcal{L}\{e^{at}\} = \frac{1}{s-a}, \quad s > a$$

$$3. \mathcal{L}\{t^n\} = \frac{n!}{s^{n+1}}, \quad s > 0$$

$$4. \mathcal{L}\{\sin(bt)\} = \frac{b}{s^2 + b^2}, \quad s > 0$$

$$5. \mathcal{L}\{\cos(bt)\} = \frac{s}{s^2 + b^2}, \quad s > 0$$

$$6. \mathcal{L}\{e^{at}t^n\} = \frac{n!}{(s-a)^{n+1}}, \quad s > a$$

$$7. \mathcal{L}\{e^{at}\sin(bt)\} = \frac{b}{(s-a)^2 + b^2}, \quad s > a$$

$$8. \mathcal{L}\{e^{at}\cos(bt)\} = \frac{s-a}{(s-a)^2 + b^2}, \quad s > a$$

$$9. \mathcal{L}\{f+g\} = \mathcal{L}\{f\} + \mathcal{L}\{g\}$$

$$10. \mathcal{L}\{cf\} = c\mathcal{L}\{f\}$$

$$11. \mathcal{L}\{e^{at}f(t)\}(s) = \mathcal{L}\{f\}(s-a)$$

$$12. \mathcal{L}\{f'\}(s) = s\mathcal{L}\{f\}(s) - f(0)$$

$$13. \mathcal{L}\{f''\}(s) = s^2\mathcal{L}\{f\}(s) - sf(0) - f'(0)$$

$$14. \mathcal{L}\{f^{(n)}\}(s) = s^n\mathcal{L}\{f\}(s) - s^{n-1}f(0) - \dots - f^{(n-1)}(0)$$

$$15. \mathcal{L}\{t^n f(t)\}(s) = (-1)^n \frac{d^n}{ds^n} \mathcal{L}\{f\}(s)$$

Properties:

Property	$f(t)$	$F(s)$
Linearity	$a_1 f_1(t) + a_2 f_2(t)$	$a_1 F_1(s) + a_2 F_2(s)$
Scaling	$f(at)$	$\frac{1}{a} F\left(\frac{s}{a}\right)$
Time shift	$f(t-a)u(t-a)$	$e^{-as} F(s)$
Frequency shift	$e^{-at} f(t)$	$F(s+a)$
Time differentiation	$\frac{df}{dt}$	$sF(s) - f(0^-)$
	$\frac{d^2 f}{dt^2}$	$s^2 F(s) - sf(0^-) - f'(0^-)$
	$\frac{d^3 f}{dt^3}$	$s^3 F(s) - s^2 f(0^-) - sf'(0^-) - f''(0^-)$
	$\frac{d^n f}{dt^n}$	$s^n F(s) - s^{n-1} f(0^-) - s^{n-2} f'(0^-) - \dots - f^{(n-1)}(0^-)$
Time integration	$\int_0^t f(t) dt$	$\frac{1}{s} F(s)$
Frequency differentiation	$tf(t)$	$-\frac{d}{ds} F(s)$
Frequency integration	$\frac{f(t)}{t}$	$\int_s^\infty F(s) ds$
Time periodicity	$f(t) = f(t+nT)$	$\frac{F_1(s)}{1 - e^{-sT}}$
Initial value	$f(0^+)$	$\lim_{s \rightarrow \infty} sF(s)$
Final value	$f(\infty)$	$\lim_{s \rightarrow 0} sF(s)$
Convolution	$f_1(t) * f_2(t)$	$F_1(s)F_2(s)$

18.9 THREE PHASE – Y

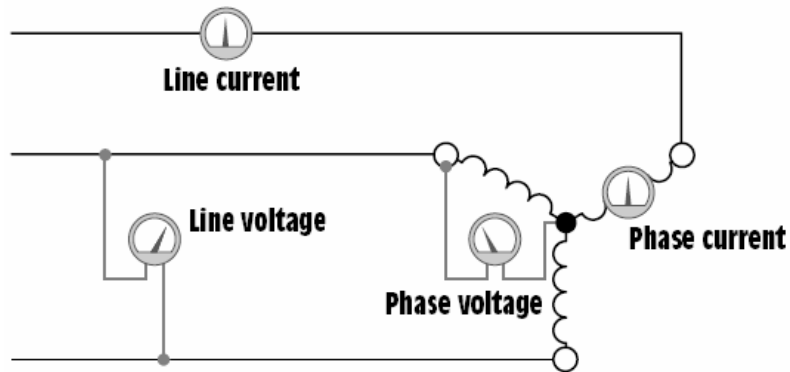

Line Voltage: $V_{LINE} = V_{PHASE} \times \sqrt{3}$

Phase Voltage: $V_{PHASE} = \frac{V_{LINE}}{\sqrt{3}}$

Line Current: $I_{LINE} = I_{PHASE}$

Phase Current: $I_{PHASE} = I_{LINE}$

Power: $S = \sqrt{3} \times V_{LINE} \times I_{LINE}$
 $S = 3 \times V_{PHASE} \times I_{PHASE}$

18.10 THREE PHASE – DELTA

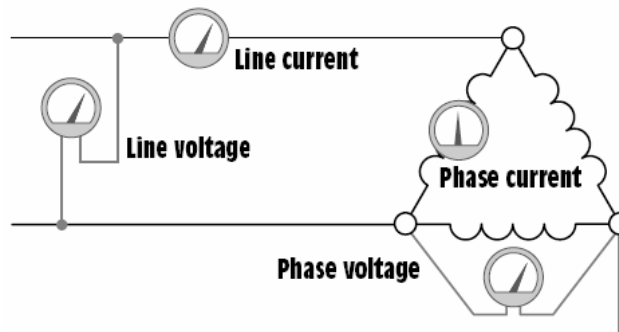

Line Voltage: $V_{LINE} = V_{PHASE}$

Phase Voltage: $V_{PHASE} = V_{LINE}$

Line Current: $I_{LINE} = I_{PHASE} \times \sqrt{3}$

Phase Current: $I_{PHASE} = \frac{I_{LINE}}{\sqrt{3}}$

Power: $S = \sqrt{3} \times V_{LINE} \times I_{LINE}$
 $S = 3 \times V_{PHASE} \times I_{PHASE}$

18.11 POWER

Instantaneous: $P(t) = V(t) \times I(t)$

Average:

$$= \frac{1}{T} \int_0^T P(t) dt = \frac{1}{2} V_{MAX} I_{MAX} \cos(\theta_V - \theta_I) = V_{RMS} I_{RMS} \cos(\theta_V - \theta_I)$$

Maximum Power: $P_{MAX} = \frac{|V_{TH}|^2}{8R_{TH}}$ where $Z_L = \overline{Z_{TH}}$

Total Power: $= I_{RMS}^2 R$

Complex Power:

$$S = V_{RMS} \overline{I_{RMS}}$$

$$S = I_{RMS}^2 Z$$

$$S = P + jQ$$

where P = Average or Active Power (W) [positive = load, negative = generator]

where Q = Reactive Power (VAr) [positive = inductive, negative = capacitive]

18.12 Electromagnetics

Definitions:

Magnetic Flux	Φ	Strength of magnetic field	Wb
Reluctance	\mathfrak{R}	Relative difficulty for flux to establish	A-t/Wb
Permeability	μ	Relative ease for flux to establish	H/m
Magnetomotive Force	\mathfrak{S}	Ability of coil to produce flux	A-t
Flux density	B	Flux per unit area	Wb/m ² or T
Magnetic Field Intensity	H	MMF per unit length	A-t/m

Permeability of free space: $\mu_0 = 4\pi \times 10^{-7} \text{ Hm}^{-1}$

Magnetic Field Intensity: $H = \frac{\mathfrak{S}}{\ell} = \frac{NI}{\ell}$

Reluctance: $\mathfrak{R} = \frac{1}{\mu A}$

Ohm's Law: $\Phi = \frac{\mathfrak{S}}{\mathfrak{R}}$ OR $\mathfrak{S} = NI$

Magnetic Force on a conductor: $F = BI\ell$

Electromagnetic Induction: $EMF = -N \frac{\Phi_2 - \Phi_1}{t}$

$EMF = Bv\ell$

Magnetic Flux: $\Phi = BA$

Electric Field: $E = \frac{F}{q} = \frac{V}{d}$

Magnetic force on a particle: $F = qvB$

PART 19: GRAPH THEORY

19.1 Fundamental Explanations

List of vertices:

$$V = \{v_1, v_2, v_3, \dots\}$$

List of edges:

$$E = \{e_1, e_2, e_3, \dots\}$$

Subgraphs:

Any subgraph H such that
 $V(H) \subset V(G) \& E(H) \subset E(G)$

Any subgraph H where $V(H) = V(G)$, there are no cycles and all vertices are connected.

Degree of vertex:

Number of edges leaving a vertex

$$\sum_{v \in V(G)} d(v) = 2|E(G)|$$

Distance:

$d(u, v)$ = Shortest path between u & v

Diameter:

$$diam(G) = \max_{u \& v \in V(G)} \{d(u, v)\}$$

Total Edges in a simple bipartite graph:

$$|E(G)| = \frac{|V(X)||V(Y)|}{2}$$

$$\sum_{x \in X} d(x) = \sum_{y \in Y} d(y)$$

Total Edges in K-regular graph:

$$|E(G)| = \frac{k(k-1)}{2}$$

19.2 Factorisation:

1 Factorisation:

A spanning union of 1 Factors and only exists if there are an even number of vertices.

1 Factors of a $K_{n,n}$ bipartite graph:

$$F_1 = [11', 22', 33', \dots]$$

$$F_2 = [12', 23', 34', \dots]$$

$$F_3 = [13', 24', 35', \dots]$$

$$F_n = \dots$$

where all numbers are MOD(n)

1 Factors of a K_{2n} graph:

$$F_0 = \{(1, \infty), (2, 0), (3, 2n-2), \dots, (n, n+1)\}$$

$$F_i = \{(i, \infty), (i+1, 2n-2+1), \dots, (i+n-1, i+n)\}$$

$$F_{2n-2} = \dots$$

Where all numbers are MOD(2n-1)

19.3 Vertex Colouring

Chromatic Number: $\chi(G) \geq 3$ if there are triangles or an odd cycle $\chi(G) \geq 2$ if is an even cycle $\chi(G) \geq n$ if is K_n is a subgraph of G **Union/Intersection:**If $G = G_1 \cup G_2$ and $G_1 \cap G_2 = K_m$, then

$$P(G, \lambda) = \frac{P(G_1, \lambda)P(G_2, \lambda)}{P(K_m, \lambda)}$$

Edge Contraction:

$$P(G, \lambda) = P(G - e, \lambda) - P(G.e, \lambda)$$

Common Chromatic Polynomials:

$$P(T_n, \lambda) = \lambda(\lambda - 1)^{n-1}$$

$$P(C_n, \lambda) = (\lambda - 1)^n + (-1)^n(\lambda - 1)$$

$$P(K_n, \lambda) = \lambda(\lambda - 1)(\lambda - 2)\dots(\lambda - n + 1)$$

- Where the highest power is the number of vertices
- Where the lowest power is the number of components
- Where the the coefficient of the 2nd highest power is the number of edges.

19.4 Edge Colouring:**Common Chromatic Polynomials:**

$$\chi'(G) \geq \Delta(G)$$

$$\chi'(K_{n,n}) = n$$

$$\chi'(C_{2n}) = 2$$

$$\chi'(C_{2n+1}) = 3$$

$$\chi'(K_{2n}) = 2n - 1$$

$$\chi'(K_{2n+1}) = 2n + 1$$

PART 99: CONVERSIONS

99.1 LENGTH:

Name of unit	Symbol	Definition	Relation to SI units
ångström	Å	$\equiv 1 \times 10^{-10}$ m	= 0.1 nm
astronomical unit	AU	\approx Distance from Earth to Sun	$\approx 149\,597\,871\,464$ m
barleycorn (H)		$\equiv \frac{1}{3}$ in (see note above about rounding)	= 8.46×10^{-3} m
bohr, atomic unit of length	a_0	\equiv Bohr radius of hydrogen	$\approx 5.291\,772\,0859 \times 10^{-11} \pm 3.6 \times 10^{-20}$ m
cable length (Imperial)		$\equiv 608$ ft	= 185.3184 m
cable length (International)		$\equiv 1/10$ nmi	= 185.2 m
cable length (U.S.)		$\equiv 720$ ft	= 219.456 m
chain (Gunter's; Surveyor's)	ch	$\equiv 66$ ft $\equiv 4$ rods	= 20.1168 m
cubit (H)		\equiv Distance from fingers to elbow ≈ 18 in	≈ 0.5 m
ell (H)	ell	$\equiv 45$ in	= 1.143 m
fathom	fm	$\equiv 6$ ft	= 1.8288 m
fermi	fm	$\equiv 1 \times 10^{-15}$ m	= 1×10^{-15} m
finger		$\equiv 7/8$ in	= 0.022 225 m
finger (cloth)		$\equiv 4\frac{1}{2}$ in	= 0.1143 m
foot (Benoît) (H)	ft (Ben)		$\approx 0.304\,799\,735$ m
foot (Clarke's; Cape) (H)	ft (Cla)		$\approx 0.304\,797\,2654$ m
foot (Indian) (H)	ft Ind		$\approx 0.304\,799\,514$ m
foot (International)	ft	$\equiv \frac{1}{3}$ yd = 12 inches	= 0.3048 m
foot (Sear's) (H)	ft (Sear)		$\approx 0.304\,799\,47$ m
foot (U.S. Survey)	ft (US)	$\equiv 1\,200/3\,937$ m	$\approx 0.304\,800\,610$ m
french; charriere	F	$\equiv \frac{1}{3}$ mm	= 3.3×10^{-4} m
furlong	fur	$\equiv 10$ chains = 660 ft = 220 yd	= 201.168 m
hand		$\equiv 4$ in	= 0.1016 m
inch	in	$\equiv 1/36$ yd = 1/12 ft	= 0.0254 m
league (land)	lea	$\equiv 3$ US Statute miles	= 4 828.032 m
light-day		$\equiv 24$ light-hours	= 2.590 206 837

			12×10^{13} m
light-hour		≡ 60 light-minutes	= 1.079 252 8488×10^{12} m
light-minute		≡ 60 light-seconds	= 1.798 754 748×10^{10} m
light-second		≡ Distance light travels in one second in vacuum	= 299 792 458 m
light-year	l.y.	≡ Distance light travels in vacuum in 365.25 days	= 9.460 730 472 5808×10^{15} m
line	ln	≡ 1/12 in	= 0.002 116 m
link (Gunter's; Surveyor's)	lnk	≡ 1/100 ch	= 0.201 168 m
link (Ramsden's; Engineer's)	lnk	≡ 1 ft	= 0.3048 m
metre (SI base unit)	m	≡ Distance light travels in 1/299 792 458 of a second in vacuum.	= 1 m
mickey		≡ 1/200 in	= 1.27×10^{-4} m
micron	μ		≡ 1×10^{-6} m
mil; thou	mil	≡ 1×10^{-3} in	= 2.54×10^{-5} m
mil (Sweden and Norway)	mil	≡ 10 km	= 10 000 m
mile	mi	≡ 1 760 yd = 5 280 ft = 80 chains	= 1 609.344 m
mile (geographical) (H)		≡ 6 082 ft	= 1 853.7936 m
mile (telegraph) (H)	mi	≡ 6 087 ft	= 1 855.3176 m
mile (U.S. Survey)	mi	≡ 5 280 <i>ft</i> (US Survey feet)	= $5\,280 \times 1\,200/3\,937$ m ≈ 1 609.347 219 m
nail (cloth)		≡ 2¼ in	= 0.057 15 m
nautical league	NL; nl	≡ 3 nmi	= 5 556 m
nautical mile (Admiralty)	NM (Adm); nmi (Adm)	≡ 6 080 ft	≡ 1 853.184 m
nautical mile (international)	NM; nmi	≡ 1 852 m	= 1 852 m
pace		≡ 2.5 ft	= 0.762 m
palm		≡ 3 in	= 0.0762 m
parsec	pc	Distance of star with <i>par</i> allax shift of one arc <i>second</i> from a base of one astronomical unit	≈ $3.085\,677\,82 \times 10^{16}$ ± 6×10^6 m
pica		≡ 12 points	Dependent on point measures.

point (American, English)	pt	$\equiv 1/72.272$ in	$\approx 0.000\ 351\ 450$ m
point (Didot; European)	pt	$\equiv 1/12 \times 1/72$ of pied du roi; After 1878: $\equiv 5/133$ cm	$\approx 0.000\ 375\ 97$ m; After 1878: $\approx 0.000\ 375\ 939\ 85$ m
point (PostScript) [11]	pt	$\equiv 1/72$ in	$= 0.000\ 352\ 7$ m
point (TeX)	pt	$\equiv 1/72.27$ in	$= 0.000\ 351\ 4598$ m
quarter		$\equiv 1/4$ yd	$= 0.2286$ m
rod; pole; perch (H)	rd	$\equiv 16\frac{1}{2}$ ft	$= 5.0292$ m
rope (H)	rope	$\equiv 20$ ft	$= 6.096$ m
span (H)		$\equiv 9$ in	$= 0.2286$ m
spat			$\equiv 1 \times 10^{12}$ m
stick (H)		$\equiv 2$ in	$= 0.0508$ m
stigma; bicron (picometre)	pm		$\equiv 1 \times 10^{-12}$ m
twip	twp	$\equiv 1/1\ 440$ in	$= 1.7638 \times 10^{-5}$ m
x unit; siegbahn	xu		$\approx 1.0021 \times 10^{-13}$ m
yard (International)	yd	$\equiv 0.9144$ m $\equiv 3$ ft $\equiv 36$ in	$\equiv 0.9144$ m

99.2 AREA:

Name of unit	Symbol	Definition	Relation to SI units
acre (international)	ac	$\equiv 1$ ch $\times 10$ ch = 4 840 sq yd	$= 4\ 046.856\ 4224$ m ²
acre (U. S. survey)	ac	$\equiv 10$ sq ch = 4 840 sq yd	$= 4\ 046.873$ m ² [15]
are	a	$\equiv 100$ m ²	$= 100$ m ²
barn	b	$\equiv 10^{-28}$ m ²	$= 10^{-28}$ m ²
barony		$\equiv 4\ 000$ ac	$= 1.618\ 742\ 568$ 96×10^7 m ²
board	bd	$\equiv 1$ in $\times 1$ ft	$= 7.741\ 92 \times 10^{-3}$ m ²
boiler horsepower equivalent direct radiation	bhp EDR	$\equiv (1$ ft ²) (1 bhp) / (240 BTU _{IT} /h)	$\approx 12.958\ 174$ m ²
circular inch	circ in	$\equiv \pi/4$ sq in	$\approx 5.067\ 075 \times 10^{-4}$ m ²
circular mil; circular thou	circ mil	$\equiv \pi/4$ mil ²	$\approx 5.067\ 075 \times 10^{-10}$ m ²
cord		$\equiv 192$ bd	$= 1.486\ 448\ 64$ m ²
dunam		$\equiv 1\ 000$ m ²	$= 1\ 000$ m ²
Guntha		$\equiv 33$ ft $\times 33$ ft ^[citation]	≈ 101.17 m ²

		<i>needed</i>]	
hectare	ha	$\equiv 10\,000\text{ m}^2$	$= 10\,000\text{ m}^2$
hide		$\approx 120\text{ ac (variable)}$	$\approx 5 \times 10^5\text{ m}^2$
rood	ro	$\equiv \frac{1}{4}\text{ ac}$	$= 1\,011.714\,1056\text{ m}^2$
shed		$\equiv 10^{-52}\text{ m}^2$	$= 10^{-52}\text{ m}^2$
square (roofing)		$\equiv 10\text{ ft} \times 10\text{ ft}$	$= 9.290\,304\text{ m}^2$
square chain (international)	sq ch	$\equiv 66\text{ ft} \times 66\text{ ft} = 1/10\text{ ac}$	$= 404.685\,642\,24\text{ m}^2$
square chain (U.S. Survey)	sq ch	$\equiv 66\text{ ft(US)} \times 66\text{ ft(US)} = 1/10\text{ ac}$	$= 404.687\,3\text{ m}^2$
square foot	sq ft	$\equiv 1\text{ ft} \times 1\text{ ft}$	$= 9.290\,304 \times 10^{-2}\text{ m}^2$
square foot (U.S. Survey)	sq ft	$\equiv 1\text{ ft (US)} \times 1\text{ ft (US)}$	$\approx 9.290\,341\,161\,327$ $49 \times 10^{-2}\text{ m}^2$
square inch	sq in	$\equiv 1\text{ in} \times 1\text{ in}$	$= 6.4516 \times 10^{-4}\text{ m}^2$
square kilometre	km ²	$\equiv 1\text{ km} \times 1\text{ km}$	$= 10^6\text{ m}^2$
square link	sq lnk	$\equiv 1\text{ lnk} \times 1\text{ lnk}$	$= 4.046\,856\,4224 \times 10^{-2}\text{ m}^2$
square metre (SI unit)	m ²	$\equiv 1\text{ m} \times 1\text{ m}$	$= 1\text{ m}^2$
square mil; square thou	sq mil	$\equiv 1\text{ mil} \times 1\text{ mil}$	$= 6.4516 \times 10^{-10}\text{ m}^2$
square mile; section	sq mi	$\equiv 1\text{ mi} \times 1\text{ mi}$	$= 2.589\,988\,110$ $336 \times 10^6\text{ m}^2$
square mile (U.S. Survey)	sq mi	$\equiv 1\text{ mi (US)} \times 1\text{ mi (US)}$	$\approx 2.589\,998 \times 10^6\text{ m}^2$
square rod/pole/perch	sq rd	$\equiv 1\text{ rd} \times 1\text{ rd}$	$= 25.292\,852\,64\text{ m}^2$
square yard	sq yd	$\equiv 1\text{ yd} \times 1\text{ yd}$	$= 0.836\,127\,36\text{ m}^2$
stremma		$\equiv 1\,000\text{ m}^2$	$= 1\,000\text{ m}^2$
township		$\equiv 36\text{ sq mi (US)}$	$\approx 9.323\,994 \times 10^7\text{ m}^2$
yardland		$\approx 30\text{ ac}$	$\approx 1.2 \times 10^5\text{ m}^2$

99.3 VOLUME:

Name of unit	Symbol	Definition	Relation to SI units
acre-foot	ac ft	$\equiv 1\text{ ac} \times 1\text{ ft} = 43\,560\text{ ft}^3$	$= 1\,233.481\,837\,547\,52\text{ m}^3$
acre-inch		$\equiv 1\text{ ac} \times 1\text{ in}$	$= 102.790\,153\,128\,96\text{ m}^3$
barrel (Imperial)	bl (Imp)	$\equiv 36\text{ gal (Imp)}$	$= 0.163\,659\,24\text{ m}^3$
barrel (petroleum)	bl; bbl	$\equiv 42\text{ gal (US)}$	$= 0.158\,987\,294\,928\text{ m}^3$
barrel (U.S. dry)	bl (US)	$\equiv 105\text{ qt (US)} = 105/32\text{ bu (US lvl)}$	$= 0.115\,628\,198\,985\,075\text{ m}^3$
barrel (U.S. fluid)	fl bl (US)	$\equiv 31\frac{1}{2}\text{ gal (US)}$	$= 0.119\,240\,471\,196\text{ m}^3$
board-foot	fbm	$\equiv 144\text{ cu in}$	$= 2.359\,737\,216 \times 10^{-3}\text{ m}^3$

			m^3
bucket (Imperial)	bkt	$\equiv 4 \text{ gal (Imp)}$	$= 0.018 184 36 \text{ m}^3$
bushel (Imperial)	bu (Imp)	$\equiv 8 \text{ gal (Imp)}$	$= 0.036 368 72 \text{ m}^3$
bushel (U.S. dry heaped)	bu (US)	$\equiv 1 \frac{1}{4} \text{ bu (US lvl)}$	$= 0.044 048 837 7086 \text{ m}^3$
bushel (U.S. dry level)	bu (US lvl)	$\equiv 2 150.42 \text{ cu in}$	$= 0.035 239 070 166 88 \text{ m}^3$
butt, pipe		$\equiv 126 \text{ gal (wine)}$	$= 0.476 961 884 784 \text{ m}^3$
coomb		$\equiv 4 \text{ bu (Imp)}$	$= 0.145 474 88 \text{ m}^3$
cord (firewood)		$\equiv 8 \text{ ft} \times 4 \text{ ft} \times 4 \text{ ft}$	$= 3.624 556 363 776 \text{ m}^3$
cord-foot		$\equiv 16 \text{ cu ft}$	$= 0.453 069 545 472 \text{ m}^3$
cubic fathom	cu fm	$\equiv 1 \text{ fm} \times 1 \text{ fm} \times 1 \text{ fm}$	$= 6.116 438 863 872 \text{ m}^3$
cubic foot	cu ft	$\equiv 1 \text{ ft} \times 1 \text{ ft} \times 1 \text{ ft}$	$= 0.028 316 846 592 \text{ m}^3$
cubic inch	cu in	$\equiv 1 \text{ in} \times 1 \text{ in} \times 1 \text{ in}$	$= 16.387 064 \times 10^{-6} \text{ m}^3$
cubic metre (SI unit)	m^3	$\equiv 1 \text{ m} \times 1 \text{ m} \times 1 \text{ m}$	$= 1 \text{ m}^3$
cubic mile	cu mi	$\equiv 1 \text{ mi} \times 1 \text{ mi} \times 1 \text{ mi}$	$= 4 168 181 825.440 579 584 \text{ m}^3$
cubic yard	cu yd	$\equiv 27 \text{ cu ft}$	$= 0.764 554 857 984 \text{ m}^3$
cup (breakfast)		$\equiv 10 \text{ fl oz (Imp)}$	$= 284.130 625 \times 10^{-6} \text{ m}^3$
cup (Canadian)	c (CA)	$\equiv 8 \text{ fl oz (Imp)}$	$= 227.3045 \times 10^{-6} \text{ m}^3$
cup (metric)	c	$\equiv 250.0 \times 10^{-6} \text{ m}^3$	$= 250.0 \times 10^{-6} \text{ m}^3$
cup (U.S. customary)	c (US)	$\equiv 8 \text{ US fl oz} \equiv 1/16 \text{ gal (US)}$	$= 236.588 2365 \times 10^{-6} \text{ m}^3$
cup (U.S. food nutrition labeling)	c (US)	$\equiv 240 \text{ mL}^{[16]}$	$= 2.4 \times 10^{-4} \text{ m}^3$
dash (Imperial)		$\equiv 1/384 \text{ gi (Imp)} = \frac{1}{2} \text{ pinch (Imp)}$	$= 369.961 751 302 08 3 \times 10^{-9} \text{ m}^3$
dash (U.S.)		$\equiv 1/96 \text{ US fl oz} = \frac{1}{2} \text{ US pinch}$	$= 308.057 599 609 375 \times 10^{-9} \text{ m}^3$
dessertspoon (Imperial)		$\equiv 1/12 \text{ gi (Imp)}$	$= 11.838 776 0416 \times 10^{-6} \text{ m}^3$
drop (Imperial)	gtt	$\equiv 1/288 \text{ fl oz (Imp)}$	$= 98.656 467 013 8 \times 10^{-9} \text{ m}^3$
drop (Imperial) (alt)	gtt	$\equiv 1/1 824 \text{ gi (Imp)}$	$\approx 77.886 684 \times 10^{-9} \text{ m}^3$
drop (medical)		$\equiv 1/12 \text{ ml}$	$= 83.03 \times 10^{-9} \text{ m}^3$
drop (metric)		$\equiv 1/20 \text{ mL}$	$= 50.0 \times 10^{-9} \text{ m}^3$
drop (U.S.)	gtt	$\equiv 1/360 \text{ US fl oz}$	$= 82.148 693 22916 \times 10^{-9} \text{ m}^3$
drop (U.S.) (alt)	gtt	$\equiv 1/456 \text{ US fl oz}$	$\approx 64.854 231 \times 10^{-9} \text{ m}^3$
fifth		$\equiv 1/5 \text{ US gal}$	$= 757.082 3568 \times 10^{-6} \text{ m}^3$
firkin		$\equiv 9 \text{ gal (US)}$	$= 0.034 068 706 056 \text{ m}^3$
fluid drachm (Imperial)	fl dr	$\equiv \frac{1}{8} \text{ fl oz (Imp)}$	$= 3.551 632 8125 \times 10^{-6} \text{ m}^3$

fluid dram (U.S.); U.S. fluidram	fl dr	$\equiv \frac{1}{8}$ US fl oz	$= 3.696\,691\,195$ $3125 \times 10^{-6} \text{ m}^3$
fluid ounce (Imperial)	fl oz (Imp)	$\equiv 1/160$ gal (Imp)	$= 28.413\,0625 \times 10^{-6} \text{ m}^3$
fluid ounce (U.S. customary)	US fl oz	$\equiv 1/128$ gal (US)	$= 29.573\,529\,5625 \times 10^{-6} \text{ m}^3$
fluid ounce (U.S. food nutrition labeling)	US fl oz	$\equiv 30 \text{ mL}^{[16]}$	$= 3 \times 10^{-5} \text{ m}^3$
fluid scruple (Imperial)	fl s	$\equiv 1/24$ fl oz (Imp)	$= 1.183\,877\,60416 \times 10^{-6} \text{ m}^3$
gallon (beer)	beer gal	$\equiv 282$ cu in	$= 4.621\,152\,048 \times 10^{-3} \text{ m}^3$
gallon (Imperial)	gal (Imp)	$\equiv 4.546\,09$ L	$= 4.546\,09 \times 10^{-3} \text{ m}^3$
gallon (U.S. dry)	gal (US)	$\equiv \frac{1}{8}$ bu (US lvl)	$= 4.404\,883\,770$ $86 \times 10^{-3} \text{ m}^3$
gallon (U.S. fluid; Wine)	gal (US)	$\equiv 231$ cu in	$= 3.785\,411\,784 \times 10^{-3} \text{ m}^3$
gill (Imperial); Noggin	gi (Imp); nog	$\equiv 5$ fl oz (Imp)	$= 142.065\,3125 \times 10^{-6} \text{ m}^3$
gill (U.S.)	gi (US)	$\equiv 4$ US fl oz	$= 118.294\,118\,25 \times 10^{-6} \text{ m}^3$
hogshead (Imperial)	hhd (Imp)	$\equiv 2$ bl (Imp)	$= 0.327\,318\,48 \text{ m}^3$
hogshead (U.S.)	hhd (US)	$\equiv 2$ fl bl (US)	$= 0.238\,480\,942\,392 \text{ m}^3$
jigger (bartending)		$\equiv 1\frac{1}{2}$ US fl oz	$\approx 44.36 \times 10^{-6} \text{ m}^3$
kilderkin		$\equiv 18$ gal (Imp)	$= 0.081\,829\,62 \text{ m}^3$
lambda	λ	$\equiv 1 \text{ mm}^3$	$= 1 \times 10^{-9} \text{ m}^3$
last		$\equiv 80$ bu (Imp)	$= 2.909\,4976 \text{ m}^3$
litre	L	$\equiv 1 \text{ dm}^3^{[17]}$	$= 0.001 \text{ m}^3$
load		$\equiv 50$ cu ft	$= 1.415\,842\,3296 \text{ m}^3$
minim (Imperial)	min	$\equiv 1/480$ fl oz (Imp) = $1/60$ fl dr (Imp)	$= 59.193\,880\,208$ $3 \times 10^{-9} \text{ m}^3$
minim (U.S.)	min	$\equiv 1/480$ US fl oz = $1/60$ US fl dr	$= 61.611\,519\,921$ $875 \times 10^{-9} \text{ m}^3$
peck (Imperial)	pk	$\equiv 2$ gal (Imp)	$= 9.092\,18 \times 10^{-3} \text{ m}^3$
peck (U.S. dry)	pk	$\equiv \frac{1}{4}$ US lvl bu	$= 8.809\,767\,541$ $72 \times 10^{-3} \text{ m}^3$
perch	per	$\equiv 16\frac{1}{2} \text{ ft} \times 1\frac{1}{2} \text{ ft} \times 1 \text{ ft}$	$= 0.700\,841\,953\,152 \text{ m}^3$
pinch (Imperial)		$\equiv 1/192$ gi (Imp) = $\frac{1}{8}$ tsp (Imp)	$= 739.923\,502$ $60416 \times 10^{-9} \text{ m}^3$
pinch (U.S.)		$\equiv 1/48$ US fl oz = $\frac{1}{8}$ US tsp	$= 616.115\,199\,218$ $75 \times 10^{-9} \text{ m}^3$
pint (Imperial)	pt (Imp)	$\equiv \frac{1}{8}$ gal (Imp)	$= 568.261\,25 \times 10^{-6} \text{ m}^3$
pint (U.S. dry)	pt (US)	$\equiv 1/64$ bu (US lvl) $\equiv \frac{1}{8}$	$= 550.610\,471$

	dry)	gal (US dry)	$3575 \times 10^{-6} \text{ m}^3$
pint (U.S. fluid)	pt (US fl)	$\equiv \frac{1}{8} \text{ gal (US)}$	$= 473.176\,473 \times 10^{-6} \text{ m}^3$
pony		$\equiv \frac{3}{4} \text{ US fl oz}$	$= 22.180\,147\,171$ $875 \times 10^{-6} \text{ m}^3$
pottle; quartern		$\equiv \frac{1}{2} \text{ gal (Imp)} = 80 \text{ fl oz (Imp)}$	$= 2.273\,045 \times 10^{-3} \text{ m}^3$
quart (Imperial)	qt (Imp)	$\equiv \frac{1}{4} \text{ gal (Imp)}$	$= 1.136\,5225 \times 10^{-3} \text{ m}^3$
quart (U.S. dry)	qt (US)	$\equiv \frac{1}{32} \text{ bu (US lvl)} = \frac{1}{4} \text{ gal (US dry)}$	$= 1.101\,220\,942$ $715 \times 10^{-3} \text{ m}^3$
quart (U.S. fluid)	qt (US)	$\equiv \frac{1}{4} \text{ gal (US fl)}$	$= 946.352\,946 \times 10^{-6} \text{ m}^3$
quarter; pail		$\equiv 8 \text{ bu (Imp)}$	$= 0.290\,949\,76 \text{ m}^3$
register ton		$\equiv 100 \text{ cu ft}$	$= 2.831\,684\,6592 \text{ m}^3$
sack (Imperial); bag		$\equiv 3 \text{ bu (Imp)}$	$= 0.109\,106\,16 \text{ m}^3$ ^[citation needed]
sack (U.S.)		$\equiv 3 \text{ bu (US lvl)}$	$= 0.105\,717\,210\,500\,64$ m^3
seam		$\equiv 8 \text{ bu (US lvl)}$	$= 0.281\,912\,561\,335\,04$ m^3 ^[citation needed]
shot		$\equiv 1 \text{ US fl oz}$	$\approx 29.57 \times 10^{-6} \text{ m}^3$
strike (Imperial)		$\equiv 2 \text{ bu (Imp)}$	$= 0.072\,737\,44 \text{ m}^3$
strike (U.S.)		$\equiv 2 \text{ bu (US lvl)}$	$= 0.070\,478\,140\,333\,76$ m^3
tablespoon (Canadian)	tbsp	$\equiv \frac{1}{2} \text{ fl oz (Imp)}$	$= 14.206\,531\,25 \times 10^{-6}$ m^3
tablespoon (Imperial)	tbsp	$\equiv \frac{5}{8} \text{ fl oz (Imp)}$	$= 17.758\,164\,0625 \times 10^{-6}$ m^3
tablespoon (metric)			$\equiv 15.0 \times 10^{-6} \text{ m}^3$
tablespoon (U.S. customary)	tbsp	$\equiv \frac{1}{2} \text{ US fl oz}$	$= 14.786\,764\,7825 \times 10^{-6}$ m^3
tablespoon (U.S. food nutrition labeling)	tbsp	$\equiv 15 \text{ mL}$ ^[16]	$= 1.5 \times 10^{-5} \text{ m}^3$
teaspoon (Canadian)	tsp	$\equiv \frac{1}{6} \text{ fl oz (Imp)}$	$= 4.735\,510\,416 \times 10^{-6}$ m^3
teaspoon (Imperial)	tsp	$\equiv \frac{1}{24} \text{ gi (Imp)}$	$= 5.919\,388\,02083 \times 10^{-6}$ m^3
teaspoon (metric)		$\equiv 5.0 \times 10^{-6} \text{ m}^3$	$= 5.0 \times 10^{-6} \text{ m}^3$
teaspoon (U.S. customary)	tsp	$\equiv \frac{1}{6} \text{ US fl oz}$	$= 4.928\,921\,595 \times 10^{-6}$ m^3
teaspoon (U.S. food nutrition labeling)	tsp	$\equiv 5 \text{ mL}$ ^[16]	$= 5 \times 10^{-6} \text{ m}^3$
timber foot		$\equiv 1 \text{ cu ft}$	$= 0.028\,316\,846\,592 \text{ m}^3$
ton (displacement)		$\equiv 35 \text{ cu ft}$	$= 0.991\,089\,630\,72 \text{ m}^3$
ton (freight)		$\equiv 40 \text{ cu ft}$	$= 1.132\,673\,863\,68 \text{ m}^3$

ton (water)		≡ 28 bu (Imp)	= 1.018 324 16 m ³
tun		≡ 252 gal (wine)	= 0.953 923 769 568 m ³
wey (U.S.)		≡ 40 bu (US lvl)	= 1.409 562 806 6752 m ³

99.4 PLANE ANGLE:

Name of unit	Symbol	Definition	Relation to SI units
angular mil	μ	≡ 2π/6400 rad	≈ 0.981 748 × 10 ⁻³ rad
arcminute	'	≡ 1°/60	≈ 0.290 888 × 10 ⁻³ rad
arcsecond	"	≡ 1°/3600	≈ 4.848 137 × 10 ⁻⁶ rad
centesimal minute of arc	'	≡ 1 grad/100	≈ 0.157 080 × 10 ⁻³ rad
centesimal second of arc	"	≡ 1 grad/(10 000)	≈ 1.570 796 × 10 ⁻⁶ rad
degree (of arc)	°	≡ π/180 rad = 1/360 of a revolution	≈ 17.453 293 × 10 ⁻³ rad
grad; gradian; gon	grad	≡ 2π/400 rad = 0.9°	≈ 15.707 963 × 10 ⁻³ rad
octant		≡ 45°	≈ 0.785 398 rad
quadrant		≡ 90°	≈ 1.570 796 rad
radian (SI unit)	rad	The angle subtended at the center of a circle by an arc whose length is equal to the circle's radius. One full revolution encompasses 2π radians.	= 1 rad
sextant		≡ 60°	≈ 1.047 198 rad
sign		≡ 30°	≈ 0.523 599 rad

99.5 SOLID ANGLE:

Name of unit	Symbol	Definition	Relation to SI units
steradian (SI unit)	sr	The solid angle subtended at the center of a sphere of radius r by a portion of the surface of the sphere having an area r ² . A sphere encompasses 4π sr. ^[14]	= 1 sr

99.6 MASS:

Name of unit	Symbol	Definition	Relation to SI units
--------------	--------	------------	----------------------

atomic mass unit, unified	u; AMU		$\approx 1.660\,538\,73 \times 10^{-27} \pm 1.3 \times 10^{-36} \text{ kg}$
atomic unit of mass, electron rest mass	m_e		$\approx 9.109\,382\,15 \times 10^{-31} \pm 45 \times 10^{-39} \text{ kg}^{[18]}$
bag (coffee)		$\equiv 60 \text{ kg}$	$= 60 \text{ kg}$
bag (Portland cement)		$\equiv 94 \text{ lb av}$	$= 42.637\,682\,78 \text{ kg}$
barge		$\equiv 22\frac{1}{2} \text{ sh tn}$	$= 20\,411.656\,65 \text{ kg}$
carat	kt	$\equiv 3\,1\frac{1}{6} \text{ gr}$	$\approx 205.196\,548\,333 \text{ mg}$
carat (metric)	ct	$\equiv 200 \text{ mg}$	$= 200 \text{ mg}$
clove		$\equiv 8 \text{ lb av}$	$= 3.628\,738\,96 \text{ kg}$
crith			$\approx 89.9349 \text{ mg}$
dalton	Da		$\approx 1.660\,902\,10 \times 10^{-27} \pm 1.3 \times 10^{-36} \text{ kg}$
dram (apothecary; troy)	dr t	$\equiv 60 \text{ gr}$	$= 3.887\,9346 \text{ g}$
dram (avoirdupois)	dr av	$\equiv 27\,11\frac{3}{32} \text{ gr}$	$= 1.771\,845\,195\,3125 \text{ g}$
electronvolt	eV	$\equiv 1 \text{ eV (energy unit) } / c^2$	$= 1.7826 \times 10^{-36} \text{ kg}$
gamma	γ	$\equiv 1 \mu\text{g}$	$= 1 \mu\text{g}$
grain	gr	$\equiv 64.798\,91 \text{ mg}$	$= 64.798\,91 \text{ mg}$
hundredweight (long)	long cwt or cwt	$\equiv 112 \text{ lb av}$	$= 50.802\,345\,44 \text{ kg}$
hundredweight (short); cental	sh cwt	$\equiv 100 \text{ lb av}$	$= 45.359\,237 \text{ kg}$
hyl (CGS unit)		$\equiv 1 \text{ gee} \times 1 \text{ g} \times 1 \text{ s}^2/\text{m}$	$= 9.806\,65 \text{ g}$
hyl (MKS unit)		$\equiv 1 \text{ gee} \times 1 \text{ kg} \times 1 \text{ s}^2/\text{m}$	$= 9.806\,65 \text{ kg}$
kilogram, grave	kg; G		(SI base unit) ^[8]
kip	kip	$\equiv 1\,000 \text{ lb av}$	$= 453.592\,37 \text{ kg}$
mark		$\equiv 8 \text{ oz t}$	$= 248.827\,8144 \text{ g}$
mite		$\equiv 1/20 \text{ gr}$	$= 3.239\,9455 \text{ mg}$
mite (metric)		$\equiv 1/20 \text{ g}$	$= 50 \text{ mg}$
ounce (apothecary; troy)	oz t	$\equiv 1/12 \text{ lb t}$	$= 31.103\,4768 \text{ g}$
ounce (avoirdupois)	oz av	$\equiv 1/16 \text{ lb}$	$= 28.349\,523\,125 \text{ g}$
ounce (U.S. food nutrition labeling)	oz	$\equiv 28 \text{ g}^{[16]}$	$= 28 \text{ g}$
pennyweight	dwt; pwt	$\equiv 1/20 \text{ oz t}$	$= 1.555\,173\,84 \text{ g}$
point		$\equiv 1/100 \text{ ct}$	$= 2 \text{ mg}$
pound (avoirdupois)	lb av	$\equiv 7\,000 \text{ grains}$	$= 0.453\,592\,37 \text{ kg}$
pound (metric)		$\equiv 500 \text{ g}$	$= 500 \text{ g}$
pound (troy)	lb t	$\equiv 5\,760 \text{ grains}$	$= 0.373\,241\,7216 \text{ kg}$

quarter (Imperial)		$\equiv 1/4 \text{ long cwt} = 2 \text{ st}$ $= 28 \text{ lb av}$	$= 12.700\,586\,36 \text{ kg}$
quarter (informal)		$\equiv 1/4 \text{ short tn}$	$= 226.796\,185 \text{ kg}$
quarter, long (informal)		$\equiv 1/4 \text{ long tn}$	$= 254.011\,7272 \text{ kg}$
quintal (metric)	q	$\equiv 100 \text{ kg}$	$= 100 \text{ kg}$
scruple (apothecary)	s ap	$\equiv 20 \text{ gr}$	$= 1.295\,9782 \text{ g}$
sheet		$\equiv 1/700 \text{ lb av}$	$= 647.9891 \text{ mg}$
slug; geepound	slug	$\equiv 1 \text{ gee} \times 1 \text{ lb av} \times 1$ s^2/ft	$\approx 14.593\,903 \text{ kg}$
stone	st	$\equiv 14 \text{ lb av}$	$= 6.350\,293\,18 \text{ kg}$
ton, assay (long)	AT	$\equiv 1 \text{ mg} \times 1 \text{ long tn} \div$ 1 oz t	$\approx 32.666\,667 \text{ g}$
ton, assay (short)	AT	$\equiv 1 \text{ mg} \times 1 \text{ sh tn} \div 1$ oz t	$\approx 29.166\,667 \text{ g}$
ton, long	long tn or ton	$\equiv 2\,240 \text{ lb}$	$= 1\,016.046\,9088 \text{ kg}$
ton, short	sh tn	$\equiv 2\,000 \text{ lb}$	$= 907.184\,74 \text{ kg}$
tonne (mts unit)	t	$\equiv 1\,000 \text{ kg}$	$= 1\,000 \text{ kg}$
wey		$\equiv 252 \text{ lb} = 18 \text{ st}$	$= 114.305\,277\,24 \text{ kg}$ (variants exist)
Zentner	Ztr.	Definitions vary; see [19] and. [14]	

99.7 DENSITY:

Name of unit	Symbol	Definition	Relation to SI units
gram per millilitre	g/mL	$\equiv \text{g/mL}$	$= 1,000 \text{ kg/m}^3$
kilogram per cubic metre (SI unit)	kg/m ³	$\equiv \text{kg/m}^3$	$= 1 \text{ kg/m}^3$
kilogram per litre	kg/L	$\equiv \text{kg/L}$	$= 1,000 \text{ kg/m}^3$
ounce (avoirdupois) per cubic foot	oz/ft ³	$\equiv \text{oz/ft}^3$	$\approx 1.001153961 \text{ kg/m}^3$
ounce (avoirdupois) per cubic inch	oz/in ³	$\equiv \text{oz/in}^3$	$\approx 1.729994044 \times 10^3 \text{ kg/m}^3$
ounce (avoirdupois) per gallon (Imperial)	oz/gal	$\equiv \text{oz/gal}$	$\approx 6.236023291 \text{ kg/m}^3$
ounce (avoirdupois) per gallon (U.S. fluid)	oz/gal	$\equiv \text{oz/gal}$	$\approx 7.489151707 \text{ kg/m}^3$
pound (avoirdupois) per cubic foot	lb/ft ³	$\equiv \text{lb/ft}^3$	$\approx 16.01846337 \text{ kg/m}^3$
pound (avoirdupois) per cubic inch	lb/in ³	$\equiv \text{lb/in}^3$	$\approx 2.767990471 \times 10^4 \text{ kg/m}^3$
pound (avoirdupois) per gallon (Imperial)	lb/gal	$\equiv \text{lb/gal}$	$\approx 99.77637266 \text{ kg/m}^3$
pound (avoirdupois) per gallon (U.S. fluid)	lb/gal	$\equiv \text{lb/gal}$	$\approx 119.8264273 \text{ kg/m}^3$
slug per cubic foot	slug/ft ³	$\equiv \text{slug/ft}^3$	$\approx 515.3788184 \text{ kg/m}^3$

99.8 TIME:

Name of unit	Symbol	Definition	Relation to SI units
atomic unit of time	au	$\equiv a_0/(\alpha \cdot c)$	$\approx 2.418\,884\,254 \times 10^{-17} \text{ s}$
Callippic cycle		$\equiv 441 \text{ mo (hollow)} + 499 \text{ mo (full)} = 76 \text{ a of } 365.25 \text{ d}$	$= 2.398\,3776 \times 10^9 \text{ s}$
century		$\equiv 100 \text{ a (see below for definition of year length)}$	$= 100 \times \text{year}$
day	d	$= 24 \text{ h}$	$= 86400 \text{ s}$
day (sidereal)	d	\equiv Time needed for the Earth to rotate once around its axis, determined from successive transits of a very distant astronomical object across an observer's meridian (International Celestial Reference Frame)	$\approx 86\,164.1 \text{ s}$
decade		$\equiv 10 \text{ a (see below for definition of year length)}$	$= 10 \times \text{year}$
fortnight		$\equiv 2 \text{ wk}$	$= 1\,209\,600 \text{ s}$
helek		$\equiv 1/1\,080 \text{ h}$	$= 3.3 \text{ s}$
Hipparchic cycle		$\equiv 4 \text{ Callippic cycles} - 1 \text{ d}$	$= 9.593\,424 \times 10^9 \text{ s}$
hour	h	$\equiv 60 \text{ min}$	$= 3\,600 \text{ s}$
jiffy		$\equiv 1/60 \text{ s}$	$= .016 \text{ s}$
jiffy (alternate)		$\equiv 1/100 \text{ s}$	$= 10 \text{ ms}$
ke (quarter of an hour)		$\equiv \frac{1}{4} \text{ h} = 1/96 \text{ d}$	$= 60 \times 60 / 4 \text{ s} = 900 \text{ s} = 60 / 4 \text{ min} = 15 \text{ min}$
ke (traditional)		$\equiv 1/100 \text{ d}$	$= 24 \times 60 \times 60 / 100 \text{ s} = 864 \text{ s} = 24 * 60 / 100 \text{ min} = 14.4 \text{ min}$
lustre; lustrum		$\equiv 5 \text{ a of } 365 \text{ d}$	$= 1.5768 \times 10^8 \text{ s}$
Metonic cycle; enneadecaeteris		$\equiv 110 \text{ mo (hollow)} + 125 \text{ mo (full)} = 6940 \text{ d} \approx 19 \text{ a}$	$= 5.996\,16 \times 10^8 \text{ s}$
millennium		$\equiv 1\,000 \text{ a (see below for definition of year length)}$	$= 1000 \times \text{year}$
milliday	md	$\equiv 1/1\,000 \text{ d}$	$= 24 \times 60 \times 60 / 1\,000 \text{ s} = 86.4 \text{ s}$
minute	min	$\equiv 60 \text{ s}$	$= 60 \text{ s}$
moment		$\equiv 90 \text{ s}$	$= 90 \text{ s}$
month (full)	mo	$\equiv 30 \text{ d}^{[20]}$	$= 2\,592\,000 \text{ s}$

month (Greg. av.)	mo	Average Gregorian month = 365.2425/12 d = 30.436875 d	$\approx 2.6297 \times 10^6$ s
month (hollow)	mo	$\equiv 29$ d ^[20]	= 2 505 600 s
month (synodic)	mo	Cycle time of moon phases ≈ 29.530589 days (Average)	$\approx 2.551 \times 10^6$ s
octaeteris		= 48 mo (full) + 48 mo (hollow) + 3 mo (full) ^{[21][22]} = 8 a of 365.25 d = 2922 d	= 2.524 608 $\times 10^8$ s
Planck time		$\equiv (G\hbar / c^5)^{1/2}$	$\approx 1.351\ 211\ 868 \times 10^{-43}$ s
second	s	time of 9 192 631 770 periods of the radiation corresponding to the transition between the 2 hyperfine levels of the ground state of the caesium 133 atom at 0 K ^[8] (but other seconds are sometimes used in astronomy)	(SI base unit)
shake		$\equiv 10^{-8}$ s	= 10 ns
sigma		$\equiv 10^{-6}$ s	= 1 μ s
Sothic cycle		$\equiv 1\ 461$ a of 365 d	= 4.607 4096 $\times 10^{10}$ s
svedberg	S	$\equiv 10^{-13}$ s	= 100 fs
week	wk	$\equiv 7$ d	= 604 800 s
year (Gregorian)	a, y, or yr	= 365.2425 d average, calculated from common years (365 d) plus leap years (366 d) on most years divisible by 4. See leap year for details.	= 31 556 952 s
year (Julian)	a, y, or yr	= 365.25 d average, calculated from common years (365 d) plus one leap year (366 d) every four years	= 31 557 600 s
year (sidereal)	a, y, or yr	\equiv time taken for Sun to return to the same position with respect to the stars of the celestial sphere	$\approx 365.256\ 363$ d $\approx 31\ 558\ 149.7632$ s
year (tropical)	a, y, or yr	\equiv Length of time it takes for the Sun to return to the same position in the cycle of seasons	$\approx 365.242\ 190$ d $\approx 31\ 556\ 925$ s

99.9 FREQUENCY:

Name of unit	Symbol	Definition	Relation to SI units
hertz (SI unit)	Hz	\equiv Number of cycles per second	= 1 Hz = 1/s
revolutions per minute	rpm	\equiv One unit rpm equals one rotation completed around a fixed axis in one minute of time.	≈ 0.104719755 rad/s

99.10 SPEED OR VELOCITY:

Name of unit	Symbol	Definition	Relation to SI units
foot per hour	fph	$\equiv 1 \text{ ft/h}$	$\approx 8.466\ 667 \times 10^{-5} \text{ m/s}$
foot per minute	fpm	$\equiv 1 \text{ ft/min}$	$= 5.08 \times 10^{-3} \text{ m/s}$
foot per second	fps	$\equiv 1 \text{ ft/s}$	$= 3.048 \times 10^{-1} \text{ m/s}$
furlong per fortnight		$\equiv \text{furlong/fortnight}$	$\approx 1.663\ 095 \times 10^{-4} \text{ m/s}$
inch per minute	ipm	$\equiv 1 \text{ in/min}$	$\approx 4.23\ 333 \times 10^{-4} \text{ m/s}$
inch per second	ips	$\equiv 1 \text{ in/s}$	$= 2.54 \times 10^{-2} \text{ m/s}$
kilometre per hour	km/h	$\equiv 1 \text{ km/h}$	$\approx 2.777\ 778 \times 10^{-1} \text{ m/s}$
knot	kn	$\equiv 1 \text{ NM/h} = 1.852 \text{ km/h}$	$\approx 0.514\ 444 \text{ m/s}$
knot (Admiralty)	kn	$\equiv 1 \text{ NM (Adm)/h} = 1.853\ 184 \text{ km/h}$ ^[citation needed]	$= 0.514\ 773 \text{ m/s}$
mach number	<i>M</i>	The ratio of the speed of an object moving through a fluid to the speed of sound in the same medium; typically used as a measure of aircraft speed.	Unitless. Actual speed of sound varies depending on atmospheric conditions. See "speed of sound" below for one specific condition.
metre per second (SI unit)	m/s	$\equiv 1 \text{ m/s}$	$= 1 \text{ m/s}$
mile per hour	mph	$\equiv 1 \text{ mi/h}$	$= 0.447\ 04 \text{ m/s}$
mile per minute	mpm	$\equiv 1 \text{ mi/min}$	$= 26.8224 \text{ m/s}$
mile per second	mps	$\equiv 1 \text{ mi/s}$	$= 1\ 609.344 \text{ m/s}$
speed of light in vacuum	<i>c</i>	$\equiv 299\ 792\ 458 \text{ m/s}$	$= 299\ 792\ 458 \text{ m/s}$
speed of sound in air	<i>s</i>		$\approx 344 \text{ m/s}$ at 20 °C, 60% relative humidity ^[23]

99.11 FLOW (VOLUME):

Name of unit	Symbol	Definition	Relation to SI units
cubic foot per minute	CFM	$\equiv 1 \text{ ft}^3/\text{min}$	$= 4.719474432 \times 10^{-4} \text{ m}^3/\text{s}$
cubic foot per second	ft^3/s	$\equiv 1 \text{ ft}^3/\text{s}$	$= 0.028316846592 \text{ m}^3/\text{s}$
cubic inch per minute	in^3/min	$\equiv 1 \text{ in}^3/\text{min}$	$= 2.7311773 \times 10^{-7} \text{ m}^3/\text{s}$
cubic inch per second	in^3/s	$\equiv 1 \text{ in}^3/\text{s}$	$= 1.6387064 \times 10^{-5} \text{ m}^3/\text{s}$
cubic metre per second (SI unit)	m^3/s	$\equiv 1 \text{ m}^3/\text{s}$	$= 1 \text{ m}^3/\text{s}$
gallon (U.S. fluid) per day	GPD	$\equiv 1 \text{ gal/d}$	$= 4.381263638 \times 10^{-8} \text{ m}^3/\text{s}$

gallon (U.S. fluid) per hour	GPH	≡ 1 gal/h	= $1.051503273 \times 10^{-6} \text{ m}^3/\text{s}$
gallon (U.S. fluid) per minute	GPM	≡ 1 gal/min	= $6.30901964 \times 10^{-5} \text{ m}^3/\text{s}$
litre per minute	LPM	≡ 1 L/min	= $1.6 \times 10^{-5} \text{ m}^3/\text{s}$

99.12 ACCELERATION:

Name of unit	Symbol	Definition	Relation to SI units
foot per hour per second	fph/s	≡ 1 ft/(h·s)	≈ $8.466\ 667 \times 10^{-5} \text{ m/s}^2$
foot per minute per second	fpm/s	≡ 1 ft/(min·s)	= $5.08 \times 10^{-3} \text{ m/s}^2$
foot per second squared	fps ²	≡ 1 ft/s ²	= $3.048 \times 10^{-1} \text{ m/s}^2$
gal; galileo	Gal	≡ 1 cm/s ²	= 10^{-2} m/s^2
inch per minute per second	ipm/s	≡ 1 in/(min·s)	≈ $4.233\ 333 \times 10^{-4} \text{ m/s}^2$
inch per second squared	ips ²	≡ 1 in/s ²	= $2.54 \times 10^{-2} \text{ m/s}^2$
knot per second	kn/s	≡ 1 kn/s	≈ $5.144\ 444 \times 10^{-1} \text{ m/s}^2$
metre per second squared (SI unit)	m/s ²	≡ 1 m/s ²	= 1 m/s ²
mile per hour per second	mph/s	≡ 1 mi/(h·s)	= $4.4704 \times 10^{-1} \text{ m/s}^2$
mile per minute per second	mpm/s	≡ 1 mi/(min·s)	= 26.8224 m/s^2
mile per second squared	mps ²	≡ 1 mi/s ²	= $1.609\ 344 \times 10^3 \text{ m/s}^2$
standard gravity	g	≡ 9.806 65 m/s ²	= 9.806 65 m/s ²

99.13 FORCE:

Name of unit	Symbol	Definition	Relation to SI units
atomic unit of force		≡ $m_e \cdot \alpha^2 \cdot c^2 / a_0$	≈ 8.238 722 06 × 10 ⁻⁸ N [24]
dyne (cgs unit)	dyn	≡ g·cm/s ²	= 10 ⁻⁵ N
kilogram-force; kilopond; grave-force	kgf; kp; Gf	≡ g × 1 kg	= 9.806 65 N
kip; kip-force	kip; kipf; klpf	≡ g × 1 000 lb	= 4.448 221 615 2605 × 10 ³ N
milligrave-force, gravet-force	mGf; gf	≡ g × 1 g	= 9.806 65 mN
newton (SI unit)	N	A force capable of giving a mass of one kg an acceleration of one meter per second, per second. [25]	= 1 N = 1 kg·m/s ²
ounce-force	ozf	≡ g × 1 oz	= 0.278 013 850 953 7812 N
pound	lb	≡ slug·ft/s ²	= 4.448 230 531 N
pound-force	lbf	≡ g × 1 lb	= 4.448 221 615 2605 N

poundal	pdl	$\equiv 1 \text{ lb}\cdot\text{ft}/\text{s}^2$	$= 0.138\,254\,954\,376 \text{ N}$
sthene (mts unit)	sn	$\equiv 1 \text{ t}\cdot\text{m}/\text{s}^2$	$= 1 \times 10^3 \text{ N}$
ton-force	tnf	$\equiv g \times 1 \text{ sh tn}$	$= 8.896\,443\,230\,521 \times 10^3 \text{ N}$

99.14 PRESSURE OR MECHANICAL STRESS:

Name of unit	Symbol	Definition	Relation to SI units
atmosphere (standard)	atm		$\equiv 101\,325 \text{ Pa}^{[26]}$
atmosphere (technical)	at	$\equiv 1 \text{ kgf}/\text{cm}^2$	$= 9.806\,65 \times 10^4 \text{ Pa}^{[26]}$
bar	bar		$\equiv 10^5 \text{ Pa}$
barye (cgs unit)		$\equiv 1 \text{ dyn}/\text{cm}^2$	$= 0.1 \text{ Pa}$
centimetre of mercury	cmHg	$\equiv 13\,595.1 \text{ kg}/\text{m}^3 \times 1 \text{ cm} \times g$	$\approx 1.333\,22 \times 10^3 \text{ Pa}^{[26]}$
centimetre of water (4 °C)	cmH ₂ O	$\approx 999.972 \text{ kg}/\text{m}^3 \times 1 \text{ cm} \times g$	$\approx 98.0638 \text{ Pa}^{[26]}$
foot of mercury (conventional)	ftHg	$\equiv 13\,595.1 \text{ kg}/\text{m}^3 \times 1 \text{ ft} \times g$	$\approx 40.636\,66 \times 10^3 \text{ Pa}^{[26]}$
foot of water (39.2 °F)	ftH ₂ O	$\approx 999.972 \text{ kg}/\text{m}^3 \times 1 \text{ ft} \times g$	$\approx 2.988\,98 \times 10^3 \text{ Pa}^{[26]}$
inch of mercury (conventional)	inHg	$\equiv 13\,595.1 \text{ kg}/\text{m}^3 \times 1 \text{ in} \times g$	$\approx 3.386\,389 \times 10^3 \text{ Pa}^{[26]}$
inch of water (39.2 °F)	inH ₂ O	$\approx 999.972 \text{ kg}/\text{m}^3 \times 1 \text{ in} \times g$	$\approx 249.082 \text{ Pa}^{[26]}$
kilogram-force per square millimetre	kgf/mm ²	$\equiv 1 \text{ kgf}/\text{mm}^2$	$= 9.806\,65 \times 10^6 \text{ Pa}^{[26]}$
kip per square inch	ksi	$\equiv 1 \text{ kipf}/\text{sq in}$	$\approx 6.894\,757 \times 10^6 \text{ Pa}^{[26]}$
micron (micrometre) of mercury	μmHg	$\equiv 13\,595.1 \text{ kg}/\text{m}^3 \times 1 \mu\text{m} \times g \approx 0.001 \text{ torr}$	$\approx 0.133\,3224 \text{ Pa}^{[26]}$
millimetre of mercury	mmHg	$\equiv 13\,595.1 \text{ kg}/\text{m}^3 \times 1 \text{ mm} \times g \approx 1 \text{ torr}$	$\approx 133.3224 \text{ Pa}^{[26]}$
millimetre of water (3.98 °C)	mmH ₂ O	$\approx 999.972 \text{ kg}/\text{m}^3 \times 1 \text{ mm} \times g = 0.999\,972 \text{ kgf}/\text{m}^2$	$= 9.806\,38 \text{ Pa}$
pascal (SI unit)	Pa	$\equiv \text{N}/\text{m}^2 = \text{kg}/(\text{m}\cdot\text{s}^2)$	$= 1 \text{ Pa}^{[27]}$
pièze (mts unit)	pz	$\equiv 1\,000 \text{ kg}/\text{m}\cdot\text{s}^2$	$= 1 \times 10^3 \text{ Pa} = 1 \text{ kPa}$
pound per square foot	psf	$\equiv 1 \text{ lbf}/\text{ft}^2$	$\approx 47.880\,25 \text{ Pa}^{[26]}$
pound per square inch	psi	$\equiv 1 \text{ lbf}/\text{in}^2$	$\approx 6.894\,757 \times 10^3 \text{ Pa}^{[26]}$
poundal per square foot	pdl/sq ft	$\equiv 1 \text{ pdl}/\text{sq ft}$	$\approx 1.488\,164 \text{ Pa}^{[26]}$

short ton per square foot		$\equiv 1 \text{ sh tn} \times g / 1 \text{ sq ft}$	≈ 95.760 $518 \times 10^3 \text{ Pa}$
torr	torr	$\equiv 101\,325/760 \text{ Pa}$	$\approx 133.3224 \text{ Pa}$ ^[26]

99.15 TORQUE OR MOMENT OF FORCE:

Name of unit	Symbol	Definition	Relation to SI units
foot-pound force	ft lbf	$\equiv g \times 1 \text{ lb} \times 1 \text{ ft}$	$= 1.355\,817\,948\,331\,4004 \text{ N}\cdot\text{m}$
foot-poundal	ft pdl	$\equiv 1 \text{ lb}\cdot\text{ft}^2/\text{s}^2$	$= 4.214\,011\,009\,380\,48 \times 10^{-2} \text{ N}\cdot\text{m}$
inch-pound force	in lbf	$\equiv g \times 1 \text{ lb} \times 1 \text{ in}$	$= 0.112\,984\,829\,027\,6167 \text{ N}\cdot\text{m}$
metre kilogram	m kg	$\equiv \text{N} \times \text{m} / g$	$\approx 0.101\,971\,621 \text{ N}\cdot\text{m}$
Newton metre (SI unit)	N·m	$\equiv \text{N} \times \text{m} = \text{kg}\cdot\text{m}^2/\text{s}^2$	$= 1 \text{ N}\cdot\text{m}$

99.16 ENERGY, WORK, OR AMOUNT OF HEAT:

Name of unit	Symbol	Definition	Relation to SI units
barrel of oil equivalent	bboe	$\approx 5.8 \times 10^6 \text{ BTU}_{59\text{ }^\circ\text{F}}$	$\approx 6.12 \times 10^9 \text{ J}$
British thermal unit (ISO)	BTU _{ISO}	$\equiv 1.0545 \times 10^3 \text{ J}$	$= 1.0545 \times 10^3 \text{ J}$
British thermal unit (International Table)	BTU _{IT}		$= 1.055\,055\,852$ $62 \times 10^3 \text{ J}$
British thermal unit (mean)	BTU _{mean}		$\approx 1.055\,87 \times 10^3 \text{ J}$
British thermal unit (thermochemical)	BTU _{th}		$\approx 1.054\,350 \times 10^3$ J
British thermal unit (39 °F)	BTU _{39 °F}		$\approx 1.059\,67 \times 10^3 \text{ J}$
British thermal unit (59 °F)	BTU _{59 °F}	$\equiv 1.054\,804 \times 10^3 \text{ J}$	$= 1.054\,804 \times 10^3$ J
British thermal unit (60 °F)	BTU _{60 °F}		$\approx 1.054\,68 \times 10^3 \text{ J}$
British thermal unit (63 °F)	BTU _{63 °F}		$\approx 1.0546 \times 10^3 \text{ J}$
calorie (International Table)	cal _{IT}	$\equiv 4.1868 \text{ J}$	$= 4.1868 \text{ J}$
calorie (mean)	cal _{mean}		$\approx 4.190\,02 \text{ J}$
calorie (thermochemical)	cal _{th}	$\equiv 4.184 \text{ J}$	$= 4.184 \text{ J}$
calorie (3.98 °C)	cal _{3.98 °C}		$\approx 4.2045 \text{ J}$
calorie (15 °C)	cal _{15 °C}	$\equiv 4.1855 \text{ J}$	$= 4.1855 \text{ J}$
calorie (20 °C)	cal _{20 °C}		$\approx 4.1819 \text{ J}$
Celsius heat unit (International Table)	CHU _{IT}	$\equiv 1 \text{ BTU}_{IT} \times 1 \text{ K}/^\circ\text{R}$	$= 1.899\,100\,534$ $716 \times 10^3 \text{ J}$

cubic centimetre of atmosphere; standard cubic centimetre	cc atm; scc	$\equiv 1 \text{ atm} \times 1 \text{ cm}^3$	$= 0.101\,325 \text{ J}$
cubic foot of atmosphere; standard cubic foot	cu ft atm; scf	$\equiv 1 \text{ atm} \times 1 \text{ ft}^3$	$= 2.869\,204\,480\,9344 \times 10^3 \text{ J}$
cubic foot of natural gas		$\equiv 1\,000 \text{ BTU}_{\text{IT}}$	$= 1.055\,055\,852\,62 \times 10^6 \text{ J}$
cubic yard of atmosphere; standard cubic yard	cu yd atm; scy	$\equiv 1 \text{ atm} \times 1 \text{ yd}^3$	$= 77.468\,520\,985\,2288 \times 10^3 \text{ J}$
electronvolt	eV	$\equiv e \times 1 \text{ V}$	$\approx 1.602\,177\,33 \times 10^{-19} \pm 4.9 \times 10^{-26} \text{ J}$
erg (cgs unit)	erg	$\equiv 1 \text{ g} \cdot \text{cm}^2/\text{s}^2$	$= 10^{-7} \text{ J}$
foot-pound force	ft lbf	$\equiv g \times 1 \text{ lb} \times 1 \text{ ft}$	$= 1.355\,817\,948\,331\,4004 \text{ J}$
foot-poundal	ft pdl	$\equiv 1 \text{ lb} \cdot \text{ft}^2/\text{s}^2$	$= 4.214\,011\,009\,380\,48 \times 10^{-2} \text{ J}$
gallon-atmosphere (imperial)	imp gal atm	$\equiv 1 \text{ atm} \times 1 \text{ gal (imp)}$	$= 460.632\,569\,25 \text{ J}$
gallon-atmosphere (US)	US gal atm	$\equiv 1 \text{ atm} \times 1 \text{ gal (US)}$	$= 383.556\,849\,0138 \text{ J}$
hartree, atomic unit of energy	E_h	$\equiv m_e \cdot \alpha^2 \cdot c^2 (= 2 \text{ Ry})$	$\approx 4.359\,744 \times 10^{-18} \text{ J}$
horsepower-hour	hp·h	$\equiv 1 \text{ hp} \times 1 \text{ h}$	$= 2.684\,519\,537\,696\,172\,792 \times 10^6 \text{ J}$
inch-pound force	in lbf	$\equiv g \times 1 \text{ lb} \times 1 \text{ in}$	$= 0.112\,984\,829\,027\,6167 \text{ J}$
joule (SI unit)	J	The work done when a force of one newton moves the point of its application a distance of one meter in the direction of the force. ^[25]	$= 1 \text{ J} = 1 \text{ m} \cdot \text{N} = 1 \text{ kg} \cdot \text{m}^2/\text{s}^2$
kilocalorie; large calorie	kcal; Cal	$\equiv 1\,000 \text{ cal}_{\text{IT}}$	$= 4.1868 \times 10^3 \text{ J}$
kilowatt-hour; Board of Trade Unit	kW·h; B.O.T.U.	$\equiv 1 \text{ kW} \times 1 \text{ h}$	$= 3.6 \times 10^6 \text{ J}$
litre-atmosphere	l atm; sl	$\equiv 1 \text{ atm} \times 1 \text{ L}$	$= 101.325 \text{ J}$
quad		$\equiv 10^{15} \text{ BTU}_{\text{IT}}$	$= 1.055\,055\,852\,62 \times 10^{18} \text{ J}$
rydberg	Ry	$\equiv R_\infty \cdot h \cdot c$	$\approx 2.179\,872 \times 10^{-18} \text{ J}$
therm (E.C.)		$\equiv 100\,000 \text{ BTU}_{\text{IT}}$	$= 105.505\,585\,262 \times 10^6 \text{ J}$

therm (U.S.)		$\equiv 100\,000 \text{ BTU}_{59^\circ\text{F}}$	$= 105.4804 \times 10^6 \text{ J}$
thermie	th	$\equiv 1 \text{ Mcal}_{\text{IT}}$	$= 4.1868 \times 10^6 \text{ J}$
ton of coal equivalent	TCE	$\equiv 7 \text{ Gcal}_{\text{th}}$	$= 29.3076 \times 10^9 \text{ J}$
ton of oil equivalent	TOE	$\equiv 10 \text{ Gcal}_{\text{th}}$	$= 41.868 \times 10^9 \text{ J}$
ton of TNT	tTNT	$\equiv 1 \text{ Gcal}_{\text{th}}$	$= 4.184 \times 10^9 \text{ J}$

99.17 POWER OR HEAT FLOW RATE:

Name of unit	Symbol	Definition	Relation to SI units
atmosphere-cubic centimetre per minute	atm ccm	$\equiv 1 \text{ atm} \times 1 \text{ cm}^3/\text{min}$	$= 1.688\,75 \times 10^{-3} \text{ W}$
atmosphere-cubic centimetre per second	atm ccs	$\equiv 1 \text{ atm} \times 1 \text{ cm}^3/\text{s}$	$= 0.101\,325 \text{ W}$
atmosphere-cubic foot per hour	atm cfh	$\equiv 1 \text{ atm} \times 1 \text{ cu ft}/\text{h}$	$= 0.797\,001\,244\,704 \text{ W}$
atmosphere-cubic foot per minute	atm·cfm	$\equiv 1 \text{ atm} \times 1 \text{ cu ft}/\text{min}$	$= 47.820\,074\,682\,24 \text{ W}$
atmosphere-cubic foot per second	atm cfs	$\equiv 1 \text{ atm} \times 1 \text{ cu ft}/\text{s}$	$= 2.869\,204\,480\,9344 \times 10^3 \text{ W}$
BTU (International Table) per hour	BTU _{IT} /h	$\equiv 1 \text{ BTU}_{\text{IT}}/\text{h}$	$\approx 0.293\,071 \text{ W}$
BTU (International Table) per minute	BTU _{IT} /min	$\equiv 1 \text{ BTU}_{\text{IT}}/\text{min}$	$\approx 17.584\,264 \text{ W}$
BTU (International Table) per second	BTU _{IT} /s	$\equiv 1 \text{ BTU}_{\text{IT}}/\text{s}$	$= 1.055\,055\,852\,62 \times 10^3 \text{ W}$
calorie (International Table) per second	cal _{IT} /s	$\equiv 1 \text{ cal}_{\text{IT}}/\text{s}$	$= 4.1868 \text{ W}$
foot-pound-force per hour	ft lbf/h	$\equiv 1 \text{ ft lbf}/\text{h}$	$\approx 3.766\,161 \times 10^{-4} \text{ W}$
foot-pound-force per minute	ft lbf/min	$\equiv 1 \text{ ft lbf}/\text{min}$	$= 2.259\,696\,580\,552\,334 \times 10^{-2} \text{ W}$
foot-pound-force per second	ft lbf/s	$\equiv 1 \text{ ft lbf}/\text{s}$	$= 1.355\,817\,948\,331\,4004 \text{ W}$
horsepower (boiler)	bhp	$\approx 34.5 \text{ lb}/\text{h} \times 970.3 \text{ BTU}_{\text{IT}}/\text{lb}$	$\approx 9.810\,657 \times 10^3 \text{ W}$
horsepower (European electrical)	hp	$\equiv 75 \text{ kp}\cdot\text{m}/\text{s}$	$= 736 \text{ W}$
horsepower (Imperial electrical)	hp	$\equiv 746 \text{ W}$	$= 746 \text{ W}$
horsepower (Imperial mechanical)	hp	$\equiv 550 \text{ ft lbf}/\text{s}$	$= 745.699\,871\,582\,270\,22 \text{ W}$
horsepower (metric)	hp	$\equiv 75 \text{ m kgf}/\text{s}$	$= 735.498\,75 \text{ W}$
litre-atmosphere per minute	L·atm/min	$\equiv 1 \text{ atm} \times 1 \text{ L}/\text{min}$	$= 1.688\,75 \text{ W}$

litre-atmosphere per second	L·atm/s	$\equiv 1 \text{ atm} \times 1 \text{ L/s}$	$= 101.325 \text{ W}$
lusec	lusec	$\equiv 1 \text{ L} \cdot \mu\text{mHg/s}^{[14]}$	$\approx 1.333 \times 10^{-4} \text{ W}$
poncelet	p	$\equiv 100 \text{ m kgf/s}$	$= 980.665 \text{ W}$
square foot equivalent direct radiation	sq ft EDR	$\equiv 240 \text{ BTU}_{\text{IT}}/\text{h}$	$\approx 70.337 \text{ 057 W}$
ton of air conditioning		$\equiv 1 \text{ t ice melted} / 24 \text{ h}$	$\approx 3 \text{ 504 W}$
ton of refrigeration (Imperial)		$\equiv 1 \text{ BTU}_{\text{IT}} \times 1 \text{ lng tn/lb} \div 10 \text{ min/s}$	$\approx 3.938 \text{ 875} \times 10^3 \text{ W}$
ton of refrigeration (IT)		$\equiv 1 \text{ BTU}_{\text{IT}} \times 1 \text{ sh tn/lb} \div 10 \text{ min/s}$	$\approx 3.516 \text{ 853} \times 10^3 \text{ W}$
watt (SI unit)	W	The power which in one second of time gives rise to one joule of energy. ^[25]	$= 1 \text{ W} = 1 \text{ J/s} = 1 \text{ N} \cdot \text{m/s} = 1 \text{ kg} \cdot \text{m}^2/\text{s}^3$

99.18 ACTION:

Name of unit	Symbol	Definition	Relation to SI units
atomic unit of action	au	$\equiv \hbar = h / 2\pi$	$\approx 1.054 \text{ 571 68} \times 10^{-34} \text{ J} \cdot \text{s}^{[28]}$

99.19 DYNAMIC VISCOSITY:

Name of unit	Symbol	Definition	Relation to SI units
pascal second (SI unit)	Pa·s	$\equiv \text{N} \cdot \text{s}/\text{m}^2, \text{ kg}/(\text{m} \cdot \text{s})$	$= 1 \text{ Pa} \cdot \text{s}$
poise (cgs unit)	P	$\equiv 10^{-1} \text{ Pa} \cdot \text{s}$	$= 0.1 \text{ Pa} \cdot \text{s}$
pound per foot hour	lb/(ft·h)	$\equiv 1 \text{ lb}/(\text{ft} \cdot \text{h})$	$\approx 4.133 \text{ 789} \times 10^{-4} \text{ Pa} \cdot \text{s}$
pound per foot second	lb/(ft·s)	$\equiv 1 \text{ lb}/(\text{ft} \cdot \text{s})$	$\approx 1.488164 \text{ Pa} \cdot \text{s}$
pound-force second per square foot	lbf·s/ft ²	$\equiv 1 \text{ lbf} \cdot \text{s}/\text{ft}^2$	$\approx 47.88026 \text{ Pa} \cdot \text{s}$
pound-force second per square inch	lbf·s/in ²	$\equiv 1 \text{ lbf} \cdot \text{s}/\text{in}^2$	$\approx 6,894.757 \text{ Pa} \cdot \text{s}$

99.20 KINEMATIC VISCOSITY:

Name of unit	Symbol	Definition	Relation to SI units
square foot per second	ft ² /s	$\equiv 1 \text{ ft}^2/\text{s}$	$= 0.09290304 \text{ m}^2/\text{s}$
square metre per second (SI unit)	m ² /s	$\equiv 1 \text{ m}^2/\text{s}$	$= 1 \text{ m}^2/\text{s}$
stokes (cgs unit)	St	$\equiv 10^{-4} \text{ m}^2/\text{s}$	$= 10^{-4} \text{ m}^2/\text{s}$

99.21 ELECTRIC CURRENT:

Name of unit	Symbol	Definition	Relation to SI units
ampere (SI base unit)	A	\equiv The constant current needed to produce a force of 2×10^{-7} newton per metre between two straight parallel	$= 1 \text{ A}$

		conductors of infinite length and negligible circular cross-section placed one metre apart in a vacuum. ^[8]	
electromagnetic unit; abampere (cgs unit)	abamp	$\equiv 10 \text{ A}$	$= 10 \text{ A}$
esu per second; statampere (cgs unit)	esu/s	$\equiv (0.1 \text{ A}\cdot\text{m/s}) / c$	$\approx 3.335641 \times 10^{-10} \text{ A}$

99.22 ELECTRIC CHARGE:

Name of unit	Symbol	Definition	Relation to SI units
abcoulomb; electromagnetic unit (cgs unit)	abC; emu	$\equiv 10 \text{ C}$	$= 10 \text{ C}$
atomic unit of charge	au	$\equiv e$	$\approx 1.602\,176\,462 \times 10^{-19} \text{ C}$
coulomb (SI unit)	C	\equiv The amount of electricity carried in one second of time by one ampere of current. ^[25]	$= 1 \text{ C} = 1 \text{ A}\cdot\text{s}$
faraday	F	$\equiv 1 \text{ mol} \times N_A \cdot e$	$\approx 96\,485.3383 \text{ C}$
statcoulomb; franklin; electrostatic unit (cgs unit)	statC; Fr; esu	$\equiv (0.1 \text{ A}\cdot\text{m}) / c$	$\approx 3.335\,641 \times 10^{-10} \text{ C}$

99.23 ELECTRIC DIPOLE:

Name of unit	Symbol	Definition	Relation to SI units
atomic unit of electric dipole moment	ea_0		$\approx 8.478\,352\,81 \times 10^{-30} \text{ C}\cdot\text{m}$

99.24 ELECTROMOTIVE FORCE, ELECTRIC POTENTIAL DIFFERENCE:

Name of unit	Symbol	Definition	Relation to SI units
abvolt (cgs unit)	abV	$\equiv 1 \times 10^{-8} \text{ V}$	$= 1 \times 10^{-8} \text{ V}$
statvolt (cgs unit)	statV	$\equiv c \cdot (1 \mu\text{J}/\text{A}\cdot\text{m})$	$= 299.792\,458 \text{ V}$
volt (SI unit)	V	The difference in electric potential across two points along a conducting wire carrying one ampere of constant current when the power dissipated between the points equals one watt.	$= 1 \text{ V} = 1 \text{ W}/\text{A} = 1 \text{ kg}\cdot\text{m}^2/(\text{A}\cdot\text{s}^3)$

99.25 ELECTRICAL RESISTANCE:

Name of unit	Symbol	Definition	Relation to SI units
ohm (SI unit)	Ω	The resistance between two points in a conductor when one volt of electric potential difference, applied to these points, produces one ampere of current in the conductor.	$= 1 \Omega = 1 \text{ V/A} = 1 \text{ kg}\cdot\text{m}^2/(\text{A}^2\cdot\text{s}^3)$

99.26 CAPACITANCE:

Name of unit	Symbol	Definition	Relation to SI units
farad (SI unit)	F	The capacitance between two parallel plates that results in one volt of potential difference when charged by one coulomb of electricity.	$= 1 \text{ F} = 1 \text{ C/V} = 1 \text{ A}^2\cdot\text{s}^4/(\text{kg}\cdot\text{m}^2)$

99.27 MAGNETIC FLUX:

Name of unit	Symbol	Definition	Relation to SI units
maxwell (CGS unit)	Mx	$\equiv 10^{-8} \text{ Wb}$	$= 1 \times 10^{-8} \text{ Wb}$
weber (SI unit)	Wb	Magnetic flux which, linking a circuit of one turn, would produce in it an electromotive force of 1 volt if it were reduced to zero at a uniform rate in 1 second.	$= 1 \text{ Wb} = 1 \text{ V}\cdot\text{s} = 1 \text{ kg}\cdot\text{m}^2/(\text{A}\cdot\text{s}^2)$

99.28 MAGNETIC FLUX DENSITY:

Name of unit	Symbol	Definition	Relation to SI units
gauss (CGS unit)	G	$\equiv \text{Mx}/\text{cm}^2 = 10^{-4} \text{ T}$	$= 1 \times 10^{-4} \text{ T}$
tesla (SI unit)	T	$\equiv \text{Wb}/\text{m}^2$	$= 1 \text{ T} = 1 \text{ Wb}/\text{m}^2 = 1 \text{ kg}/(\text{A}\cdot\text{s}^2)$

99.29 INDUCTANCE:

Name of unit	Symbol	Definition	Relation to SI units
henry (SI unit)	H	The inductance of a closed circuit that produces one volt of electromotive force when the current in the circuit varies at a uniform rate of one ampere per second.	$= 1 \text{ H} = 1 \text{ Wb/A} = 1 \text{ kg}\cdot\text{m}^2/(\text{A}\cdot\text{s}^2)$

99.30 TEMPERATURE:

Name of	Symbol	Definition	Conversion to
---------	--------	------------	---------------

unit			kelvin
degree Celsius	°C	°C = K – 273.15. A unit of °C is the same size as a unit of K; however, their numerical values differ as the zero point of Celsius is set at 273.15 K (the ice point).	[K] = [°C] + 273.15
degree Delisle	°De		[K] = 373.15 – [°De] × 2/3
degree Fahrenheit	°F	0 °F ≡ freezing pt. of H ₂ O+NaCl, 180°F between freezing and boiling pt of H ₂ O @ 1atm	[K] = ([°F] + 459.67) × 5/9
degree Newton	°N		[K] = [°N] × 100/33 + 273.15
degree Rankine	°R; °Ra	0 °R ≡ absolute zero	[K] = [°R] × 5/9
degree Réaumur	°Ré		[K] = [°Ré] × 5/4 + 273.15
degree Rømer	°Rø		[K] = ([°Rø] – 7.5) × 40/21 + 273.15
kelvin (SI base unit)	K	≡ 1/273.16 of the thermodynamic temperature of the triple point of water.	1 K

99.31 INFORMATION ENTROPY:

Name of unit	Symbol	Definition	Relation to SI units	Relation to bits
SI unit	J/K	≡ J/K	= 1 J/K	
nat; nip; nepit	nat	≡ k_B	= $1.380\,650\,5(23) \times 10^{-23}$ J/K	
bit; shannon	bit; b; Sh	≡ $\ln(2) \times k_B$	= $9.569\,940\,(16) \times 10^{-24}$ J/K	= 1 bit
ban; hartley	ban; Hart	≡ $\ln(10) \times k_B$	= $3.179\,065\,3(53) \times 10^{-23}$ J/K	
nibble		≡ 4 bits	= $3.827\,976\,0(64) \times 10^{-23}$ J/K	= 2 ² bit
byte	B	≡ 8 bits	= $7.655\,952\,(13) \times 10^{-23}$ J/K	= 2 ³ bit
kilobyte (decimal)	kB	≡ 1 000 B	= $7.655\,952\,(13) \times 10^{-20}$ J/K	
kilobyte (kibibyte)	KB; KiB	≡ 1 024 B	= $7.839\,695\,(13) \times 10^{-20}$ J/K	= 2 ¹⁰ bit

99.32 LUMINOUS INTENSITY:

Name of unit	Symbol	Definition	Relation to SI units
candela (SI base unit); candle	cd	The luminous intensity, in a given direction, of a source that emits monochromatic radiation of frequency 540×10^{12} hertz and that has a radiant	= 1 cd

		intensity in that direction of 1/683 watt per steradian.	
candlepower (new)	cp	\equiv cd The use of <i>candlepower</i> as a unit is discouraged due to its ambiguity.	$= 1$ cd
candlepower (old, pre-1948)	cp	Varies and is poorly reproducible. Approximately 0.981 cd.	≈ 0.981 cd

99.33 LUMINANCE:

Name of unit	Symbol	Definition	Relation to SI units
candela per square foot	cd/ft ²	\equiv cd/ft ²	≈ 10.763910417 cd/m ²
candela per square inch	cd/in ²	\equiv cd/in ²	$\approx 1,550.0031$ cd/m ²
candela per square metre (SI unit);	cd/m ²	\equiv cd/m ²	$= 1$ cd/m ²
footlambert	fL	$\equiv (1/\pi)$ cd/ft ²	≈ 3.4262590996 cd/m ²
lambert	L	$\equiv (10^4/\pi)$ cd/m ²	$\approx 3,183.0988618$ cd/m ²
stilb (CGS unit)	sb	$\equiv 10^4$ cd/m ²	$\approx 1 \times 10^4$ cd/m ²

99.34 LUMINOUS FLUX:

Name of unit	Symbol	Definition	Relation to SI units
lumen (SI unit)	lm	\equiv cd·sr	$= 1$ lm = 1 cd·sr

99.35 ILLUMINANCE:

Name of unit	Symbol	Definition	Relation to SI units
footcandle; lumen per square foot	fc	\equiv lm/ft ²	$= 10.763910417$ lx
lumen per square inch	lm/in ²	\equiv lm/in ²	$\approx 1,550.0031$ lx
lux (SI unit)	lx	\equiv lm/m ²	$= 1$ lx = 1 lm/m ²
phot (CGS unit)	ph	\equiv lm/cm ²	$= 1 \times 10^4$ lx

99.36 RADIATION - SOURCE ACTIVITY:

Name of unit	Symbol	Definition	Relation to SI units
becquerel (SI unit)	Bq	\equiv Number of disintegrations per second	$= 1$ Bq = 1/s
curie	Ci	$\equiv 3.7 \times 10^{10}$ Bq	$= 3.7 \times 10^{10}$ Bq
rutherford (H)	rd	$\equiv 1$ MBq	$= 1 \times 10^6$ Bq

99.37 RADIATION - EXPOSURE:

Name of unit	Symbol	Definition	Relation to SI units
roentgen	R	1 R $\equiv 2.58 \times 10^{-4}$ C/kg	$= 2.58 \times 10^{-4}$ C/kg

99.38 RADIATION - ABSORBED DOSE:

Name of unit	Symbol	Definition	Relation to SI units
gray (SI unit)	Gy	$\equiv 1 \text{ J/kg} = 1 \text{ m}^2/\text{s}^2$	= 1 Gy
rad	rad	$\equiv 0.01 \text{ Gy}$	= 0.01 Gy

99.39 RADIATION - EQUIVALENT DOSE:

Name of unit	Symbol	Definition	Relation to SI units
Röntgen equivalent man	rem	$\equiv 0.01 \text{ Sv}$	= 0.01 Sv
sievert (SI unit)	Sv	$\equiv 1 \text{ J/kg}$	= 1 Sv